

Radio Controlled  
**Soaring Digest**  
November 2022 Vol. 37, No. 11



# The New RC Soaring Digest

November, 2022  
Vol. 37, No. 11

Title	Subtitle	Page
In The Air	Back down the rabbit hole.	3
Silent Arrow® Introduces Wide Body Variant	Progress continues for the unique, autonomous cargo glider.	8
Dream 2700   A Tailless Tale	Part I: Where This Came From	10
Flying the Seiser Alm	A not so iconic flight on an iconic slope.	20
CG Scale on the Cheap	Looking to restore a little balance to your life?	25
Building the Rico-SHE LW	Part I: The Lightweight Version of the Classic Racer from Phoenix Model Products	38
Rhönadler 35	Part II: Into the Tender Hands Of Gravity	53
The Slingsby King Kite	Part V: Tricky Ailerons, Wing Sheeting and Fuselage Fairing	59
Science for Model Flyers	Part I: The Periodic Table	69
Soaring the Sky Podcast	E122: Amelia The Glider Pilot	104
Bespoke Battery Packs	Your battery doesn't fit in that broomstick? Build one that does!	106
Stamps That Tell a Story	Wave soaring and the altitude records of Bill Ivans set in 1950 over Bishop, California.	110
Glider Patents	US 4,248,394: Remote Control Hang Glider Towing Aircraft	116
Rediscovering Martin Simons	Part IV: Center of gravity as discussed in the noted author's model aircraft books.	136
The Trailing Edge	The Ed is crabby again.	148

Click on any row to go directly to that article.

## In The Air



Bob Jennings' gorgeous, mammoth, own-design BAE Systems Nimrod MRA4 gets hurled into the wild blue at the Power Scale Soaring Association's event at the Great Orme, Wales on October 8th and 9th, 2022. Is it our imagination, or is there a de Havilland Comet buried in there somewhere? Also, check out this month's 'The Trailing Edge' article, where we're featuring more photos of this amazing aircraft. (credit: Phil Cooke)

## Back down the rabbit hole.

Some number of issues back, I provided a warning in advance when I was about to head down the rabbit hole on some sort of technical matter or another. This is another one of those times. For those who are not interested in my salty thoughts on the Zuckernaut, scroll down and have at the new issue. You'll find plenty of interest, without a doubt. On the other hand, for those who are ready for a techy 'ramble round the houses', cinch up the five point harness and hang on.

## Facebook: Friend or Foe?

For those who think that good writing accompanied by superior photography is enough for a world to beat a path to your editorial

door, think again. For all the hours devoted to producing the New RCSD, only 51% of these hours are devoted to actually creating or curating all of that good stuff. Fully 29% of this same precious and finite resource is devoted to what the social media *les enfants terrible* call 'discoverability'. In other words, hanging up your 'digital shingle' in various places where you think potential readers may just see it at some point. And when they see it, be sufficiently intrigued to reward you with a click to see – and maybe even read – some of the story behind that click.

These 'places', of course, are the various social media platforms most or all of which you will have heard: in the case of the New RCSD, the primary ones are Facebook, Instagram, Twitter, LinkedIn and our mailing list. We have, for some time, had a process in place which allows RCSD (in a GDPR-compliant manner, of course) to determine from which of these platforms a reader is coming when they arrive at RCSD's doorstep to view and read a story. Here's the headline: 52% of the stories read on the New RCSD start with the reader seeing the article on Facebook and clicking on it. As I like to say, all of the other digital shingles are tied for last – the percentages are so small as to be too small to care much about. But not quite.

Based on this simple fact, it would seem that without Facebook, we would have half as many readers. If you add in the other social platforms, which make a puny contribution by comparison, we would have only a third of the readers we have today.

At first blush, this might seem like the deal of the century: all the benefit and it costs absolutely nothing. Not one thin dime. In all of the 23 issues to date, we have spent **not one penny** with Facebook. But as Paul Newman was to have said: "If you're playing a poker game and you look around the table and can't tell who the sucker is, it's you."

Facebook is 'free' like broadcast television is 'free'. I'm not saying the *you* buy every new fast food advertised on TV just when you're hungriest but *somebody* is, otherwise there wouldn't be so many of exactly these kind of ads. So it is with Facebook, for which there is

\$39.4 billion† in profit screaming *your* eyeballs – when eyeballing Facebook – are the conduits for money leaving *your* pocket and winding up in theirs. Exactly how it does is irrelevant but if you think you and I are the exception to the rule—thinking everybody *else* is a sucker, just not you and me well, I’m sorry, we’re both wrong.

So while Facebook is the molotov cocktail torching the fabric of our society and taking democracy with it in the bargain, should we take consolation that as we all go to hell in a hand basket we think we’re getting a bunch of cool stuff for free?

So where am I going with all of this? To be candid, I’m not exactly sure. However, should we as a society decide that despite social media being ‘free’ we’re still paying *way* too high a price for it in so many ways, *then we need to take another path*. If that beautiful pipe dream were ever to come true, then there is just one pretty significant downside:

*From whence will many of our future readers come?*

And what will you, the reader be prepared to pay – if anything – when you (hopefully) arrive at our threshold? Dare I dream for just a very tiny fraction of *your* \$5.05, which is what every human on Planet Earth contributed to Facebook’s profit in 2021. After all, these pennies would pay for something you consciously want as opposed to – just spitballin’ here – whatever further mayhem Facebook has in mind for it.

## A Question for the Hive Mind

The New RCSD recently received an intriguing enquiry for which nobody around here had a ready answer:

It’s a commercial requirement for an autonomous sailplane with 40–50kg payload capacity and auto-soar capability. Of course, there are the very successful HAPS-type vehicles like the Airbus *Zephyr*, but the enquirer said that approach as “too fragile” given their intention is to

do a type of flight research in adverse weather conditions. Under non-disclosure they described what they are contemplating and it looks pretty cool.

Based on the requirements as I understand them, the aircraft would be a full-strength 'scale up' of the largest carbon-fibre RC sailplanes out there, or a 'scale down' from a full-size sailplane to get to the target payload. If you're aware of anybody who either has or is working on such an aircraft by all means please get in touch and we'll try and connect the interested parties.

## On With the Show, This Is It!

Just in case anybody is wondering, whenever I wrap up one of these monthly tomes, in the back of my mind I always hear the Looney Tunes theme. Y'know the one which features Bugs Bunny and Daffy Duck on stage belting out:

Overture, curtains, lights,  
This is it, the night of nights  
No more rehearsing and nursing a part  
We know every part by heart

For those who don't have a clue what it is I'm talking about, I have linked the classic 'toon in *Resources* below. I howl every time I see it.

And with that, I'll offer my deepest thanks to all of this month's contributors – this is a really special issue – and a extra special thank you to you, the reader.

Finally, I'll simply bid you all fair winds and blue skies,

A handwritten signature in black ink, appearing to read "Tony". The signature is stylized with a long horizontal stroke at the top and a large loop at the bottom.

## Resources

- † [Statista](#) – The source of the Facebook profit information referenced in this article.
- [PiNa.cz](#) – Cover photographer Martin Pilný’s website.
- [VVmodel](#) – Cover subject Vašek Vojtíšek’s website.

***Cover photo:** This month’s elegant, contemplative cover photo was taken by Martin Pilný at a local F3G competition held in Litomyšl in the Czech Republic on 9th July 2022. It shows Vašek Vojtíšek checking the weather conditions before the start of the next round of the competition. Martin’s description of his equipment setup: “Nikon D500 + 70–200 f/2.8E FL”. You are welcome to download the November 2022 cover in a resolution suitable for computer monitor wallpaper. ([2560x1440](#)).*

***Disclaimer:** While all reasonable care is taken in the preparation of the contents of the New RC Soaring Digest, the publishers are not legally responsible for errors in its contents or for any loss arising from such errors, including loss resulting from the negligence of our staff. Reliance placed upon the contents of the New RC Soaring Digest is solely at the readers’ own risk.*

*Here’s the [first article](#) in the November, 2022 issue. Or go to the [table of contents](#) for all the other great articles. A PDF version of this edition of In The Air, or the entire issue, is available [upon request](#).*

---

## Silent Arrow® Introduces Wide Body Variant



"The new GD-2000 Wide Body. Human shown for scale." (credit/caption: Silent Arrow®)

### Progress continues for the unique, autonomous cargo glider.

LOS ANGELES, October 16, 2022 – Chip Yates, the founder and CEO of Silent Arrow, recently provided the New RC Soaring Digest with another update of their Silent Arrow autonomous glider program. In a surprising development, the new GD-2000 Wide Body is 60% larger than the GD-2000 and can carry up to 140cu/ft of payload weighing in at up to 635kg (1,400lbs) in their patented, single-use airframe.

The Silent Arrow is a tandem-wing, disposable, programmable autonomous vehicle developed to conduct military resupply and civilian disaster relief missions. It has an effective 14.6m (48ft), spring-loaded wingspan to be stowed inside the 3.96m (13ft) fuselage for compact transportation to the theater of operations.

---





(credit: Silent Arrow®)

With the wings in the stowed position during transport, the glider can be deployed from the C-17, C-130, CH-53, V-22 and other side-door aircraft. It can also be deployed as a helicopter sling load with wings closed and static-line deployed, or wings already open and locked in flight position.

When asked what market imperative prompted the Wide Body concept to be developed, Yates said in a quote exclusive to New RCSD:

“I’m as surprised as you are about how big this thing is, but we are receiving direction from our government customers that conflicts of the future require the ability to fly in a large number of these Wide Bodies, set up an improvised capability under austere conditions, then just as quickly move on to the next objective.”

We’ll continue to follow this story which represents novel use of autonomous glider technology for both civil and military applications.

©2022

---

## Dream 2700 | A Tailless Tale

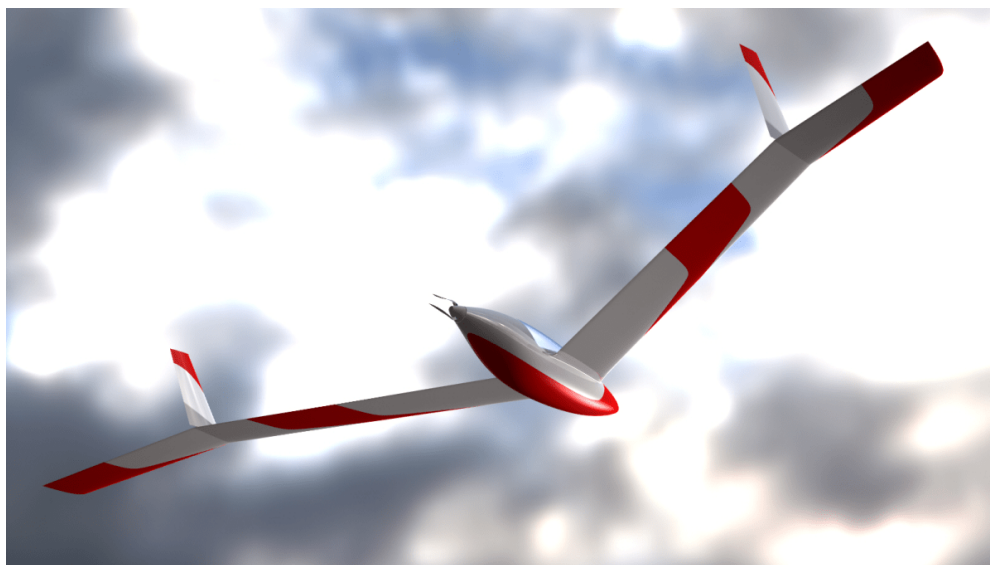

The final configuration of Dream 2700.

### Part I: Where This Came From

This is the story of my own-design, tailless glider – please sit down and relax, is going to be a long story!

Since I was a child, flying has been my dream. Airplanes are my passion since I can remember. I started with control line models, moved to RC models, and after I started flying for real with hang gliders, paragliders, ultralights and sailplanes. Today I own a beautiful *LS6* sailplane, and a paraglider. I've always dreamed about designing my own tailless glider. Over the years, I've been exploring different tailless concepts. This series of articles is dedicated to the evolution of my design concept, from the original idea up to the 1:5 scale model. It's name is *Dream 2700*.

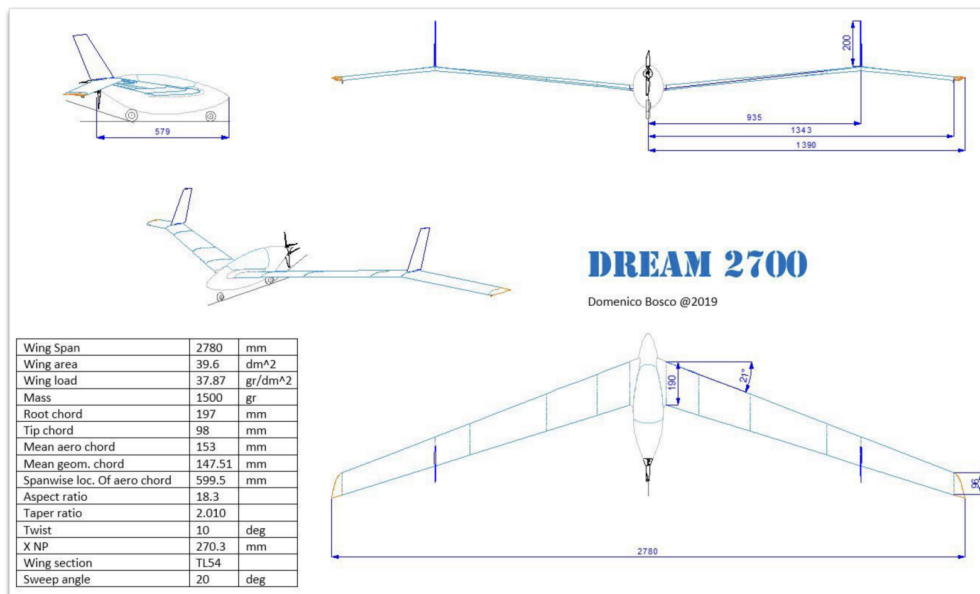

## Why Tailless?

Because tailless sailplanes look beautiful and simple. Unfortunately, reality is a bit different: they are for sure beautiful, but they are as well extremely complex. They have some very specific advantages, but at the same time there are several issues that must be mitigated with very careful and complex design work.

In anything at all, perfection is finally attained not when there is no longer anything to add, but when there is no longer anything to take away — Antoine de Saint-Exupéry

## Advantages

- Their reduced directional stability allows to get in exchange very good spiral stability, and this is a plus for thermal soaring.
- A well-designed tailless sailplane can achieve good stall performance and can be very resistant to spins.
- Friction drag can be minimised.
- The design architecture is ideal for a motorized version. An engine can be easily installed in a pusher configuration (getting as well a stabilizing effect).
- It can be cheap to build, not having a long fuselage and tails. Not so sure about that, though.

- A flying wing is absolutely a fascinating and very attractive design.

## Disadvantages

- In order to achieve good stability and control performance, several compromises need to be made, leading to a potential reduction in pure performance.
- The center of gravity allowable range is small, and must be precisely defined.
- Any control surface movement will affect the ideal lift distribution on the wing, producing secondary effects, like an increase in induced drag.
- Adverse yaw can be a big issue. However, there are new developments helping us, thanks to Albion Bowers! See *Resources* below.
- Pitch damping is an issue, due to the very small inertia on the lateral axis. PIO (pilot induced oscillations) are not rare for flying wing designs.
- Lateral stability can be an issue.
- It is true that there is only a wing to be built but, when it comes to swept wings, difficult aero/structural challenges come into the picture.

I'm convinced that some of these critical factors can be solved by a well thought design optimisation. In a tailless wing design, is very difficult to get the right trade-off between good performance, easy handling, and low production costs, when compared to traditional designs.

I'm very happy to see that this architecture is a bit revitalized nowadays (see Prandtl wing study at NASA, by Albion Bowers, Armstrong Flight Research Center Chief Scientist, in *Resources*) but the number of airplanes that will use this configuration will be still niche compared to the traditional architectures.

Nevertheless, the interest regarding some of the advantages given by that architecture, and the fashion connected to it, makes flying wing and tailless gliders far from disappearing from the scene.

I've always been attracted by both the design and the challenges connected to this configuration, and this is the reason why I started dreaming of my own tailless glider design.

## The Design Evolution: First Concepts

Inspiration came from the *Swift* foot-launched glider (see *Resources*), that still remains the most successful tailless ultralight glider that reached the market. I wanted to see if it was possible to design a better streamlined sailplane, still keeping the advantage of the foot-launch method. In the meantime, *Swift* reached its third design evolution, raising again the bar!

Back in 2000, I started with a quite conservative aspect ratio and a thick wing section. One of the biggest issues was to find the right compromise for the pilot position with respect to the wing spar, and minimising the center of gravity shift between the pilot 'running' and the 'seated' configuration. The lift distribution over the wing was close to elliptical, and two big winglets were implemented.

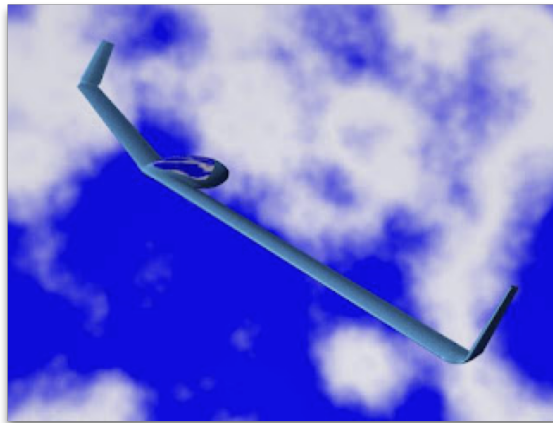

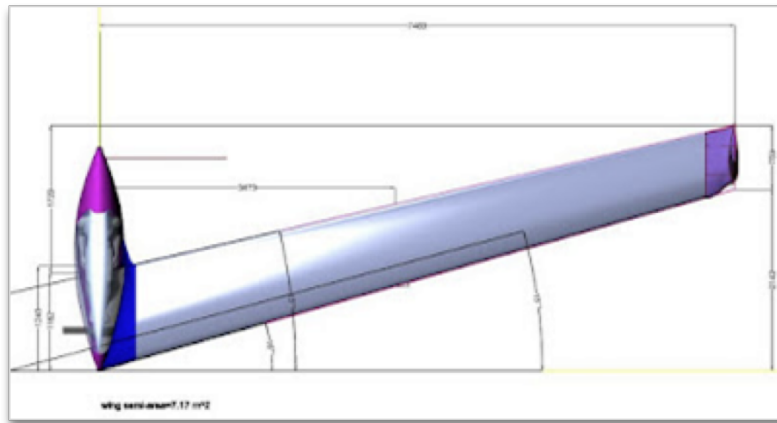

Left: My first design iteration, back in 2000. | Right: Foot launch configuration study.

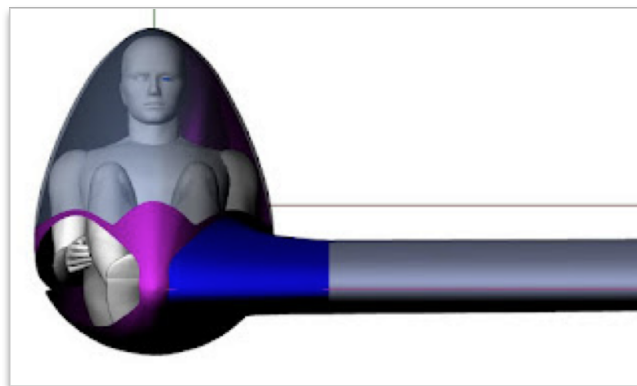
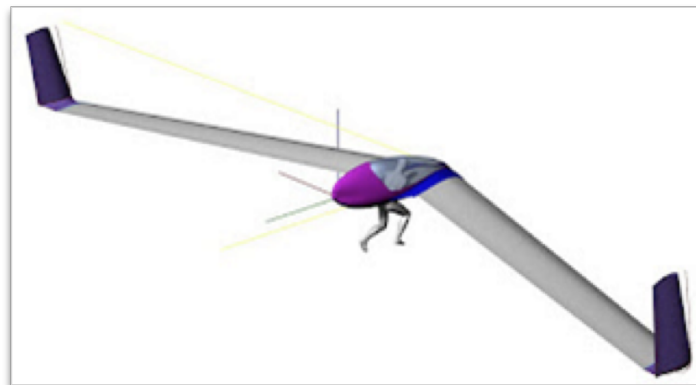

Left: The swept angle was limited to  $15^\circ$ . The wing surface was good enough for a low stall speed, making foot-launching possible. | Right: Year 2000: a very tight and streamlined fuselage pod.

In 2001–2002 I ran some aerodynamic and stability simulations. At that time, there was no ‘easy-to-use’ software for that. Searching on the web, I was able to find some freely available basic VLM code (vortex lattice method) in FORTRAN. Those codes were mainly coming from NASA and some US Universities. No GUI (graphic

interface) was available at that time, and the software was quite complex. Nevertheless I was able to prove the concept.

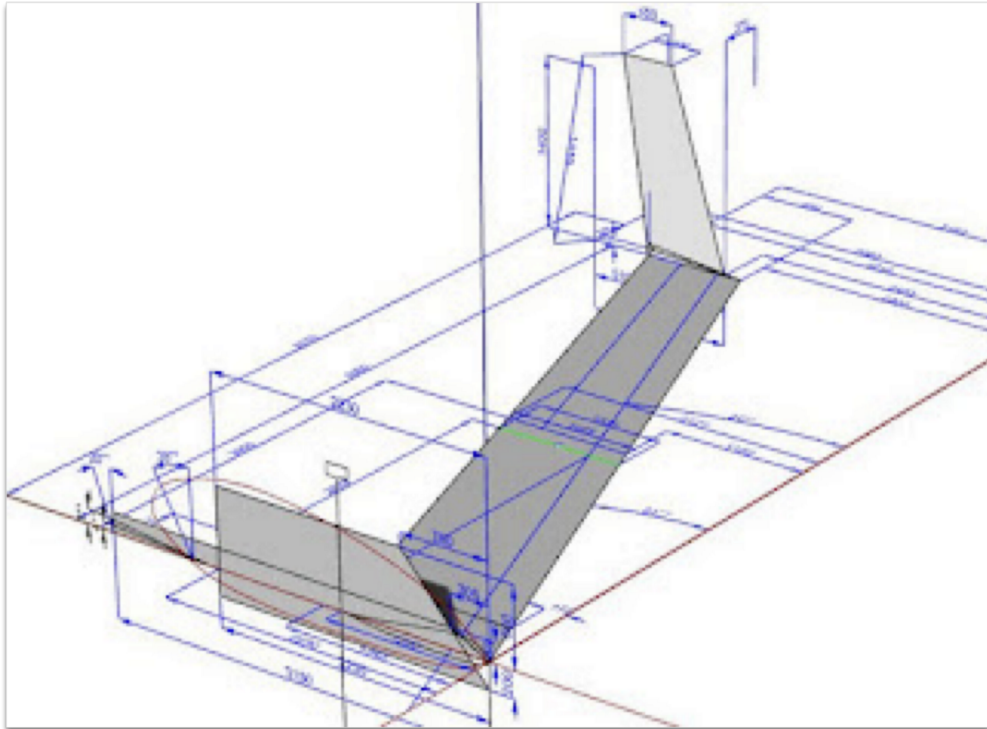

The panel model used in the VLM code.

In 2004 the design evolved to an higher aspect ratio wing, and the swept angle increased to  $22^\circ$ . The winglets were very nicely blended with the wing. The first free flight scale model was built and flown.

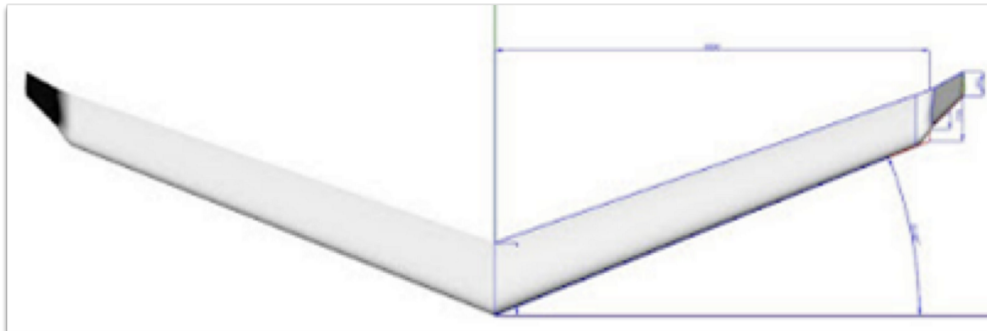

At that point, a great source of inspiration was Martin Hepperle's website (see *Resources* below for link) and the wing section chosen for the wing was the MH-78. This wing section was specifically developed for foot-launched gliders.

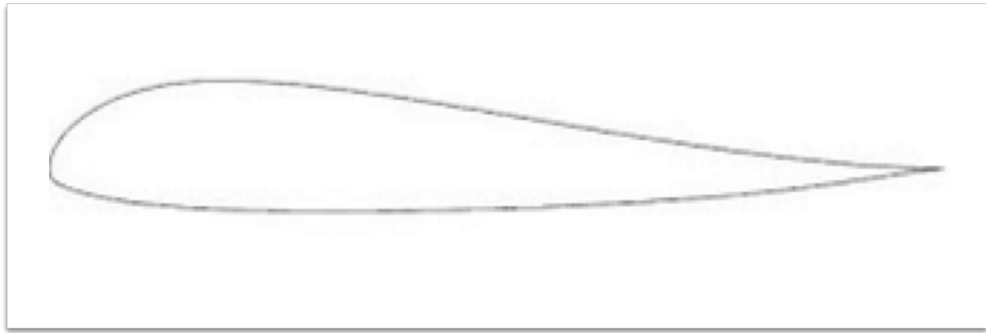

MH-78 wing section.

In 2010–2011 I started investigating the prone pilot position: a fascinating configuration, but there are several drawbacks. The most annoying one is to find a good streamline for the fuselage.

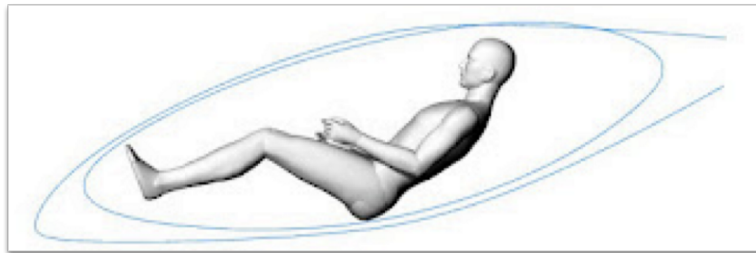
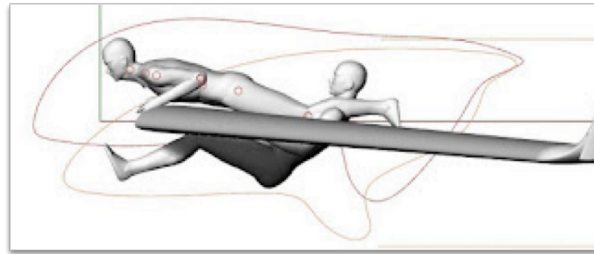

After several studies, I decided to go for the traditional seated position, as shown on the right, above.

## Shaping the Fuselage Pod

After a pause that lasted a couple of years, I focused on optimising the fuselage shape. I thought it was good to take as a reference some well known fuselage designs. The one below is belongs to the Rolladen Schneider *LS6*:



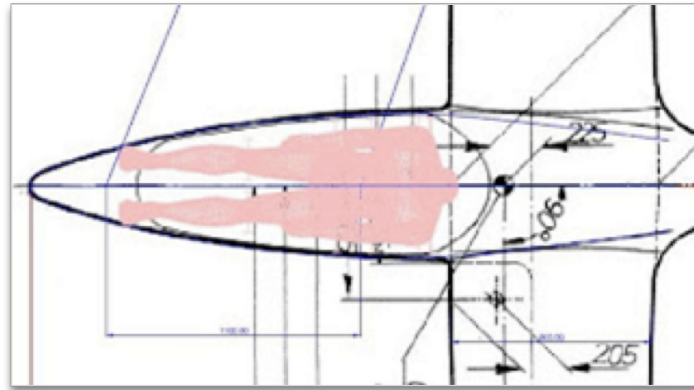
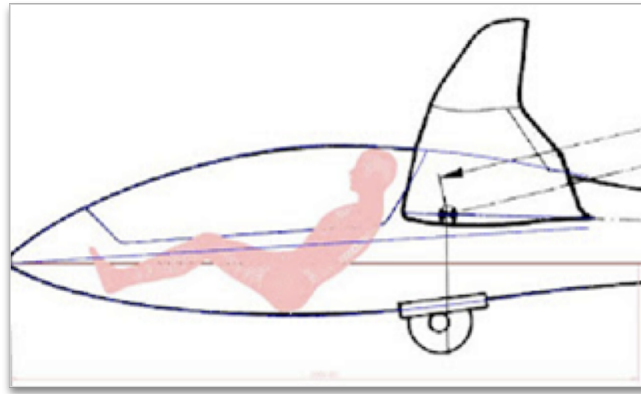

The *LS6* is quite an old glider, but this fuselage design has been used on several sailplanes, from *LS4* to *LS8*, providing very good performance. The difficulty with my design, is due to the fact that, more than a fuselage, i just need a pilot pod, since the glider will be a tailless one. So, I needed to optimize the shape in order to provide a good pressure gradient recovery on a reduced longitudinal length. The first conceptual design was still having some issues to be addressed (see picture immediately below). The wing incidence at the root was not optimised, the wing intersection with the pod was too much in the front, leading to a difficult blending of the wing, and the adverse pressure recovery at the end of the pod was critical.

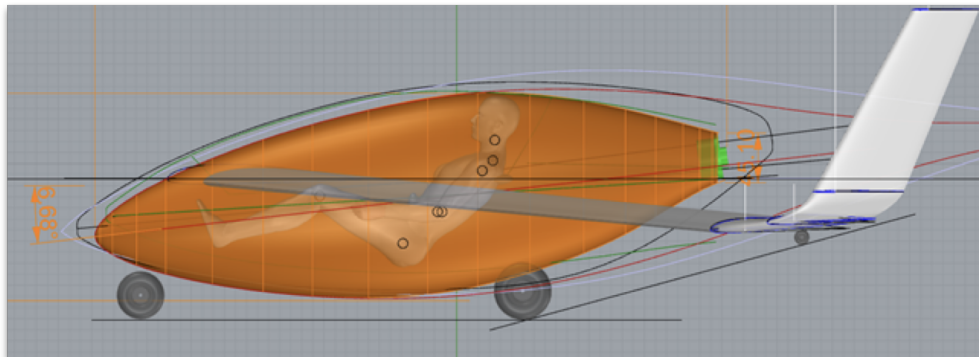

After some more iterations, this is what the design was looking like:

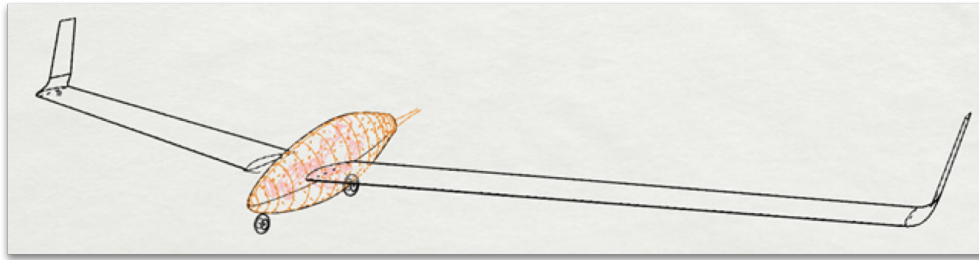

You may recognize there is quite an angle, almost  $7^\circ$ , between fuselage centreline and wing root chord. The wing is heavily twisted (we will see it later), and this brings  $7^\circ$  root chord incidence in trimmed conditions.

Up to this development stage, all decisions have been made considering a full scale aircraft: this is the reason why the fuselage pod is so big when compared to RC scale sailplanes. My final objective was, and it still is, to build a full-scale sailplane for myself. The financials connected with that are huge, and I do not know if I will be able to manage it at a certain point of time. But dreams are what drives our inspiration and commitment to work on personal projects, right?

In Part II of this series I will cover the design optimization of both wing and fuselage pod. Reynolds number plays a heavy role on the selection of wing profiles and fuselage shapes. What I will share in part II will be related to the scale model. Hoping you find this interesting, see you next time!

©2022

## Resources

- [\*On Wings of the Minimum Induced Drag: Spanload Implications for Aircraft and Birds\*](#) by Albion Bowers et al – “For nearly a century Ludwig Prandtl’s lifting-line theory remains a standard tool for understanding and analyzing aircraft wings. The tool, said Prandtl,

initially points to the elliptical spanload as the most efficient wing choice...”

- [\*Aerodynamics of Model Aircraft\*](#) by Martin Hepperle – “This is a web site about model aircraft, airfoils, propellers and aerodynamics....”
- [\*Horten Flying Wings Believers\*](#) on Facebook – This group is a good source of inspiration: “Place your Horten work here and tell about the positive yaw instead of adverse yaw. Tell about the lightness of the spar, tell about the great looks, tell about test you have done...”
- [\*Tailless Aircraft in Theory and Practice\*](#) by Karl Nickel and Michael Wohlfahrt – For the description of advantages and disadvantages, I took inspiration from the book: “discusses the full range of tailless designs, from hanggliders to the US ‘Stealth Bomber’, and includes a detailed look at particularly significant designs...”
- [\*Aériane Swift\*](#) From Wikipedia: – “The Aériane Swift is a lightweight (48 kg) foot-launched tailless sailplane whose rigid wings have a span of 40 feet. The Swift has been succeeded by the *Swift’Lite*. Although designed in California, Swift aircraft are now manufactured by Aériane, a European firm based in Gembloux, Belgium...”

*All images by the author. Read the [next article](#) in this issue, return to the [previous article](#) in this issue or go to the [table of contents](#). A PDF version of this article, or the entire issue, is available [upon request](#).*

## Flying the Seiser Alm



My AirOne does battle with the Sciliar Massif.

### **A not so iconic flight on an iconic slope.**

There are many sites available to the slope flying enthusiast, but there is a shortlist of places that have a magic ring to it. Slopes you know from great videos on YouTube and slopes that you read about in the magazines. Torrey Pines, Monte Lema, Hahnenmoos – that category. During my model flying career I have visited a good number of slopes, but one that kept haunting me has always been the Seiser Alm. A motorhome trip to Austria seemed like a good opportunity for a visit.

---



Driving in the Dolomiti mountains is a joy on its own.

The Seiser Alm (or Alpe di Siusi, in Italian) is a huge alpine meadow area located in the northern Italian Dolomiti mountains. The area is called South Tyrol and is very much connected to the Austrian province of Tyrol. You hear more people speaking German than Italian. Driving through the Dolomiti mountains can be challenging as the roads are ever winding. Navigating our medium-sized motorhome over these roads takes some effort on the steering muscles, but the reward is a constantly changing landscape with spectacular views of bare, pointy, vertically rising mountain peaks.

The flying spot on the Seiser Alm is located at the top of the Spitzbühl chairlift at an altitude of 1940m. You can drive all the way to the base of the chairlift, but only very early as the road closes for the day at 9am. Today the Spitzbühl lift is closed due to works. The chairlift is no option anyway because of our Labrador Waldo who joins us. We take the cabin lift from the valley, from the top station we hike the good part of an hour to reach the Spitzbühl. The hike is a little steep for the first 15 minutes, then the trail gets a more comfortable gradient and we truly enjoy the hike. The views are amazing, with differently shaped mountains and landscapes in every direction.

---



Magnificent views in every direction. Two gliders are packed in a trekking backpack that sits comfortably on my back during the hike.

Reaching the Spitzbühl flying spot we first enjoy a nice lunch in the restaurant overlooking the start area. My lunch is a traditional wood board with different meats, cheeses and bread. Somehow this tastes so much better having sore legs, breathing thin mountain air and enjoying a fitting view.



A traditional Alpine lunch: a meat and cheese platter with bread.

When I assemble my two gliders several paragliders appear, taking over the area. They do a lot of tandem flights from this location. I patiently wait until they depart before I throw my *AirOne* model over

the edge. What follows is a bit of a disappointment. I know that on this location you don't really soar the slope wind, but you use mainly thermals (see *Resources* below for my previous article on this subject). Despite the excellent sunny weather, the thermals are hard to find and even harder to use effectively. Every now and then the model gets two seconds of rising air and I cheer "I found it!", but next thing you know the lift has reversed to sink. The model loses quite some altitude but I don't want to use the motor unless absolutely necessary. Somehow I struggle my way back to eye level, but I do not manage to get a lot higher.



Struggling to make the most of the messy lift.

But it's not all bad news. Finally I'm standing at this iconic location with its unmistakable panoramic view. To my left the Sciliar Massif, bare rocks sticking vertically from the Earth forming a range of peaky mountain tops – just like in the YouTube videos I have always admired. It's a truly jaw-dropping scene and a perfect background for dramatic soaring videos. Despite the mediocre flying conditions I enjoy every second of this flight.

---



The Sciliar Massif make for a dramatic background for my flight. See also the key photo above the title.

The normal landing field is closed for works in the area, so I have to land the glider on the starting spot at my feet. No problem with a four-flapped F3B wing, but a big scale glider would pose a challenge here and now. Normally a nice landing field is available next to the restaurant and the big ones can be flown there.

Unfortunately the conditions on this day have not been as perfect as in many of the movies I watched. Yet I am totally satisfied with the whole experience. The very enjoyable hike to the flying spot, the superb views while flying and the knowledge that I have flown on the Seiser Alm make for an unforgettable day. And I do have a good excuse to keep this location on the to-do list. One day I *will* fly the Seiser Alm as it's meant to be.

I'll be back.



## CG Scale on the Cheap

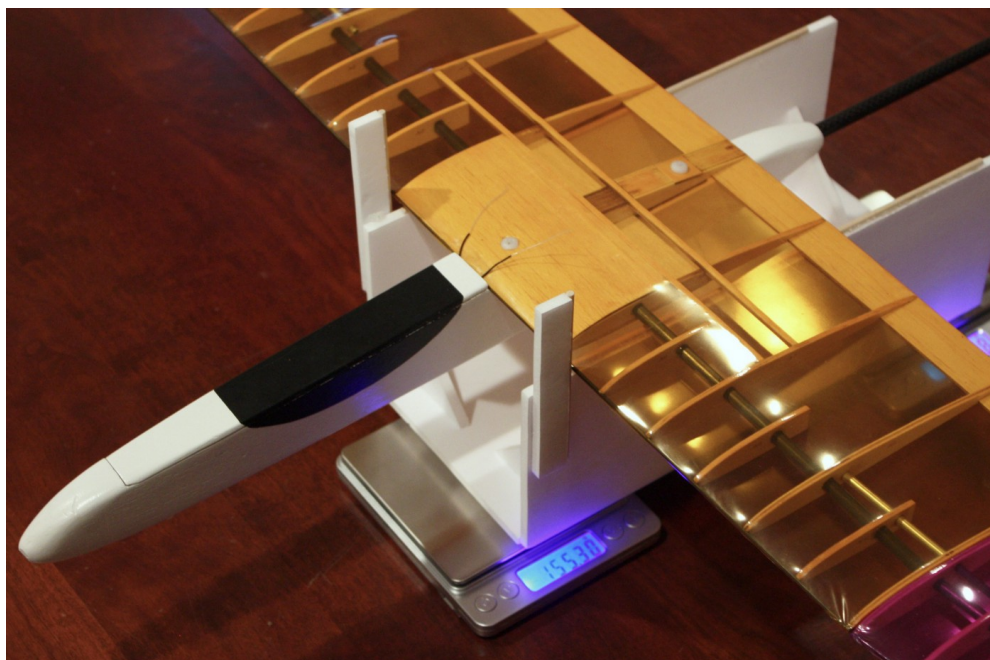

The completed cheap and cheerful CG scale doing its thing.

## Looking to restore a little balance to your life?

Many here will no doubt be familiar with the nifty electronic center-of-gravity (CG) scales that have come onto the market in recent years. I first saw one in a build video by Paul Naton and marveled at the ingenuity and accuracy of the device. Quite reasonably priced at about \$200 bucks, many builders and pilots will find the commercial units well worth the investment – they appear to be very well designed and constructed and very accurate.

That said, a CG scale is more of a convenience than a necessity and with a bit of trial and error folks can and always have been able to finely adjust CG manually, myself included. Still, the ability to easily determine and record CG in an accurate, repeatable way and to test model CG weight shifts quickly on the bench really is pretty nice. With that in mind, I wanted to try designing an inexpensive DIY scale made from common, easily accessible materials and parts. Several folks on

*RCGroups* have worked out designs in wood or for 3D printing, generally emulating the designs of the commercial units. These are a good option too, but my goal was to avoid machining entirely and instead build something from that humblest of all RC hobby materials – *foamboard*.

## Design

The idea here is to build the scale's frame from foamboard to sit on a pair of inexpensive, widely available electronic gram scales (see *\*NOTE* below for single scale use) which run from \$10 to \$20 bucks depending on the rated maximum weight and/or desired accuracy. \$10 will get you a scale that can handle up to 5kg at a resolution of 1g, while \$15-20 buys a scale that can handle up to 500g or 1kg at resolutions of 0.01g (see *Resources* below).

Going through several prototypes I began like others trying to emulate the commercial designs, but the results were unacceptably flimsy or inaccurate or both. Stepping back to consider the most fundamental design requirements, I found there are really just two elements of the scale where construction must be done with real precision, shown in the diagram below: 1) the distance  $\ell$  between points *a* and *b* where the scale frame contacts the electronic scales – i.e. the 'contact points' – and 2) the 90° vertical alignment of the wing leading edge point *c* and contact point *a* on the front scale. (fig. 1)

With elements *a*, *b*, *c* and  $\ell$  measured and positioned accurately, the CG distance from the wing leading edge is found with the following simple formula (see *Resources* below for calc spreadsheet) where  $w^1$  and  $w^2$  are the weight readings of the front and rear scales respectively:

$$(w^2 * \ell) \div (w^1 + w^2)$$

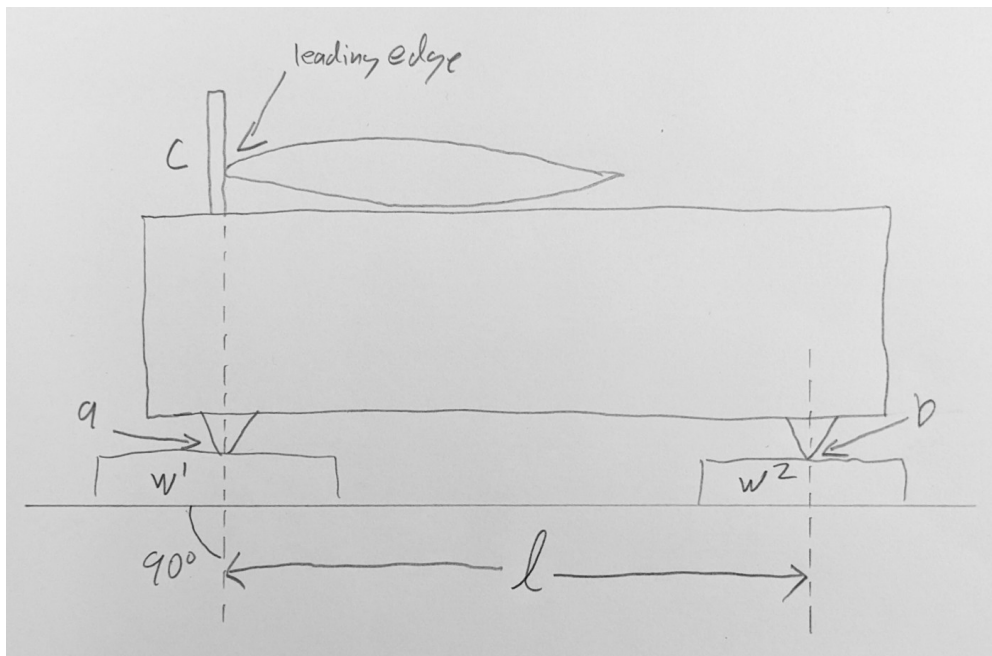

fig. 1 Diagram of build elements requiring precision.

With this understanding I eventually came up with a simpler overall approach where foamboard's inherent lack of rigidity and strength could be mitigated and the desired precision of 1) and 2) described above could be achieved easily. After a bit more prototyping I'm happy with the result detailed here and hope anyone with the desire can build this scale with not much more than foamboard and the most basic model building supplies.

**\*NOTE** – the frame as designed/built for two scales can be used with a single scale, but there would be two measurement steps because you must first measure the **total weight** of the model – i.e. the simplified formula is  $(w^2 * l) \div (\text{total weight})$  so you would replace the front scale with a riser to match the height of the rear scale to keep the frame level and then use as described to record the rear scale  $w^2$  value. To measure the total weight, simply use the frame placed fully on the scale – i.e. centered on the scale with neither contact point touching your workbench.

## Supplies

- 1 sheet foam board
- 1/8" dowel (wood, carbon rod, bamboo skewers or similar)

- Hot glue gun
- Sharp razor knife or X-Acto + extra blades
- T-square or other right-angle gauge
- Ruler with mm spacing
- Straight edge for cutting foamboard
- Medium grit sandpaper (e.g. 120)

## Measuring and Cutting

All parts are made of foamboard (I use Adams Readi-Board available at Dollar Tree stores in the US but any similar foamboard can be used) and a single 36" 1/8" dowel cut to the dimensions below. Cutting foamboard is best done with very sharp blades so plan to replace the blade a couple of times in cutting the parts list below.

### Foamboard Parts (fig. 2)

It may be clear how to layout the foamboard cuts from fig. 2, but this is how I did it:

- First square up the bottom and right edges of the board using the t-square and a straight edge to cut the new edges.
- Use the t-square to lay out vertical lines at 10cm, 10cm, 12cm and 3 cm. and a horizontal line at 28cm.
- Cut along the four vertical lines to get four blanks.
- Lay out six horizontal lines at 1.5cm increments at the top of the first 10cm wide board for the four contact point platform pieces and the two leading edge stops.
- Lay out two horizontal lines at 5cm increments and 1 vertical line at 5cm at the top of the second 10cm wide board to get four 5cm x 5cm blanks for the eight right triangle reinforcements.
- Lay out 1 line at 12cm on the 12cm wide board for the 12cm x 12cm right angle tool.
- Draw 45° lines on the 5 right angle blanks in the previous laid out in the two steps.

Use straight edge to cut along layout lines to give you the following parts:

- (2) 10cm x 28cm
- (1) 12cm x 28cm
- (1) 3cm x 20cm
- (6) 1.5cm x 10cm
- (8) 5cm x 5cm (right triangles)
- (1) 12cm x 12cm (right triangle)

**Dowel Parts** (fig. 3)

## Construction

First up is preparing the pieces making up the base of the frame:

- Using a t-square or similar draw two parallel lines 240mm apart on the bottom of the 12cm x 28cm piece. (fig. 4)
- Strip the foamboard paper from one side of four of the 1.5cm x 10cm pieces. (fig. 4)
- Using sandpaper attached to some kind of flat block (I'm using a paint stick here), sand a small 45° chamfer on one bare foamboard edge of each of the four small pieces. (fig. 5)
- Two of each chamfered pieces will be used to create platforms for the dowel contact points with a small gully where the dowel will sit accurately centered over the two lines drawn on the base. (fig. 6, carbon rod shown to illustrate the gully and alignment more clearly)

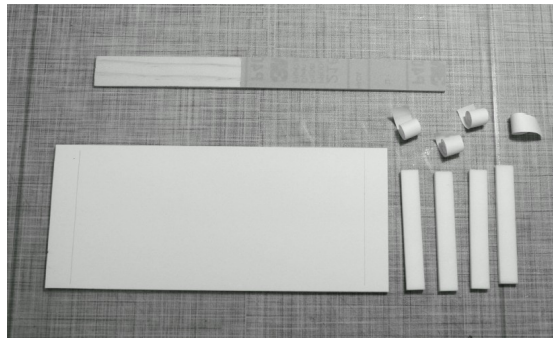

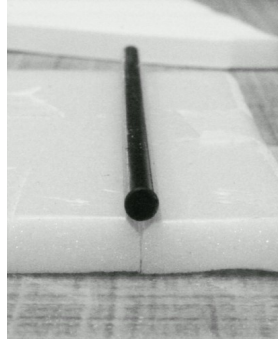
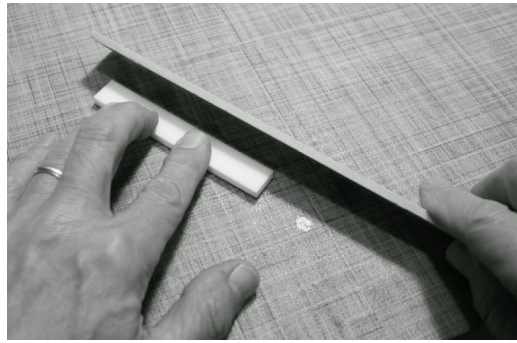
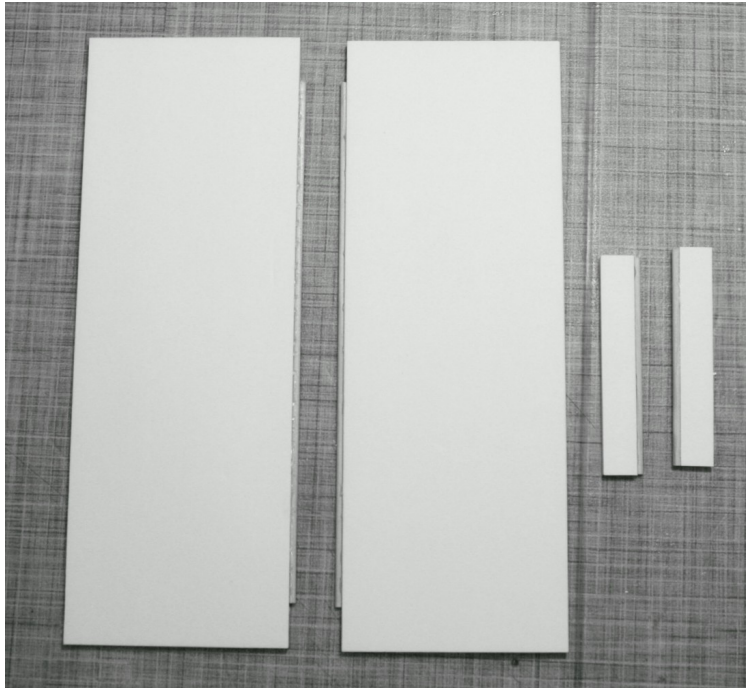

fig. 4 Scale bottom parts | fig. 5 Chamfering contact point platform parts | fig. 6 Illustration of rod in chamfered gully

- Next, prepare the two 10cm x 28cm sides of the frame and the two 1.5cm x 10cm wing leading edge stops by hot gluing the 24cm and 10cm dowels to the foamboard pieces as shown at left. (fig. 7 and 8)
- Hot glue one side piece to the bottom piece at a 90° right angle. (fig. 9)
- Hot glue 4 of the small 5cm x 5cm right angle braces to reinforce and align the joint to 90°. (fig. 10)
- Repeat the previous two steps to glue the other side of the frame, resulting in the finished part shown at right. (fig. 10)



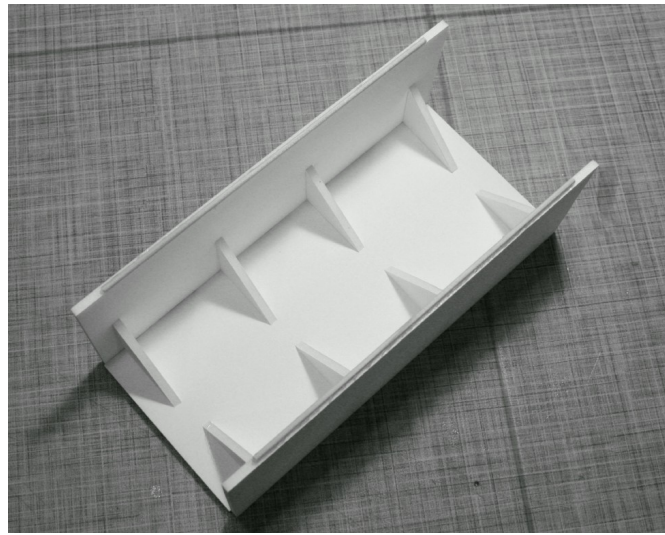
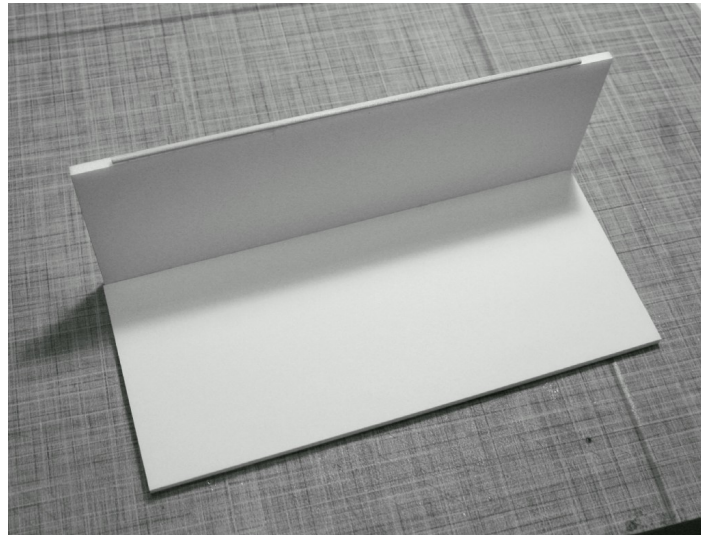

fig. 7 Hot glued dowel | fig. 8 Scale sides and leading edge stops | fig. 9 Frame side in place | fig. 10 Completed sides with triangle reinforcements

The following two image sequences detail the technique used to allow the wing leading edge stop point **c** to align precisely over the front scale's contact point **a**. Please be sure your **work table is level** for this phase of the construction.

- Hot glue one chamfered piece with the chamfer facing up and its edge right up to the parallel line at the front of the frame. (fig. 11 & 12)
- (not shown) Hot glue two of the chamfered pieces to form the contact point **b** gulley at the 2nd parallel line at the rear of the frame.
- Temporarily affix the 3cm x 20cm piece with its edge contacting the front edge of the glued chamfered piece. The extension past



the sides of the frame will then allows us to use a right angle to precisely align the leading edge stops' points **c** with contact point **a**. (fig. 13)

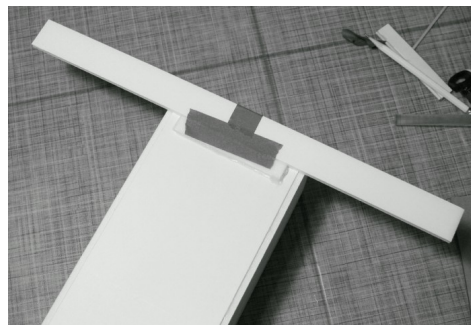
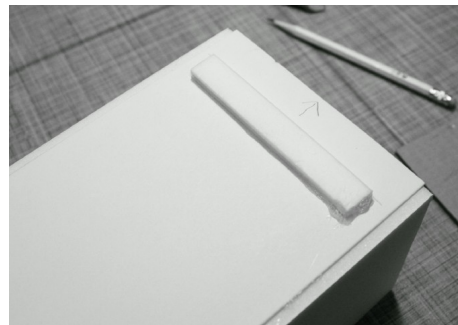
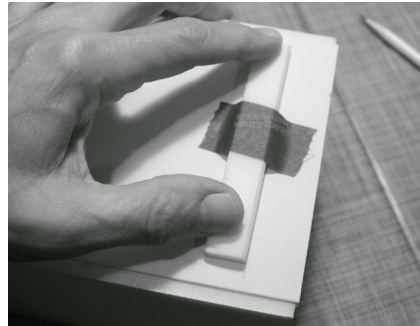

fig. 11 Chamfered piece in position | fig. 12 Hot glued in place | fig. 13 Temporary extension piece taped in place

- Tape down the frame and the extension to the table and the large right angle piece to the frame side with its forward edge against the extension. (fig. 14)
- The forward edge of the triangle is then used to position and glue the leading edge stop to the side of the frame, aligning it accurately with the center of the platform gully where the 10cm rod will become contact point **a**. (fig. 15 and 16)
- Repeat the same for the other side of the frame.

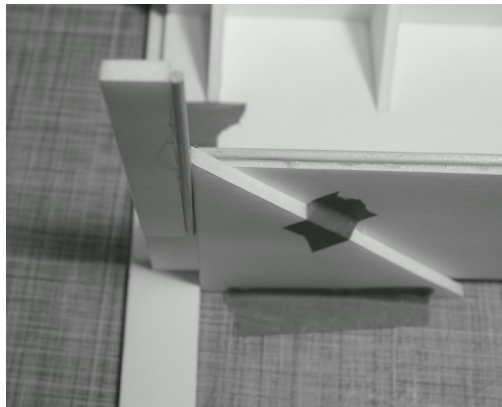
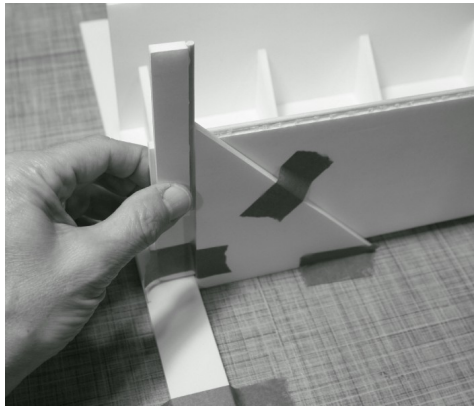
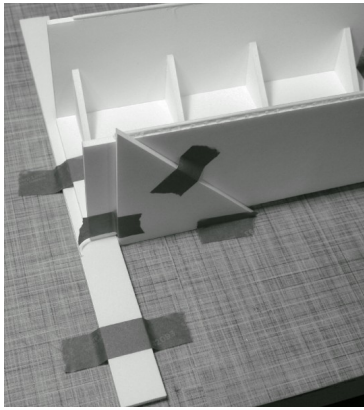

fig. 14 Preparing jig for wing stop | fig. 15 Stop in position | fig. 16 Stop hot glued in place

- Remove the temporary point *a* extension and hot glue the remaining chamfered piece to form the contact point *a* gully. (fig. 17)
- Finally, carefully position and hot glue the 2 remaining 10cm rods into the gully's of the two platforms, completing scale contact points *a* and *b*. (fig. 18 and 19)

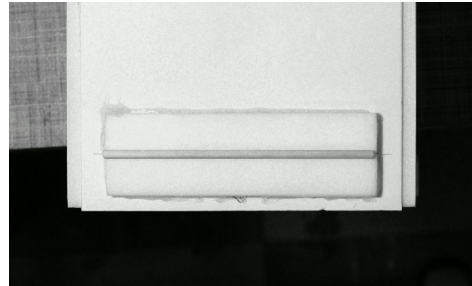
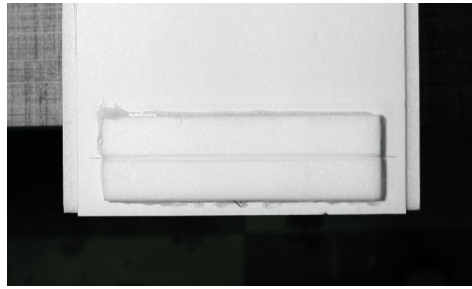

fig. 17 Dowel platform gully | fig. 18 Dowel hot glued into gully | fig. 19 Both dowels in place

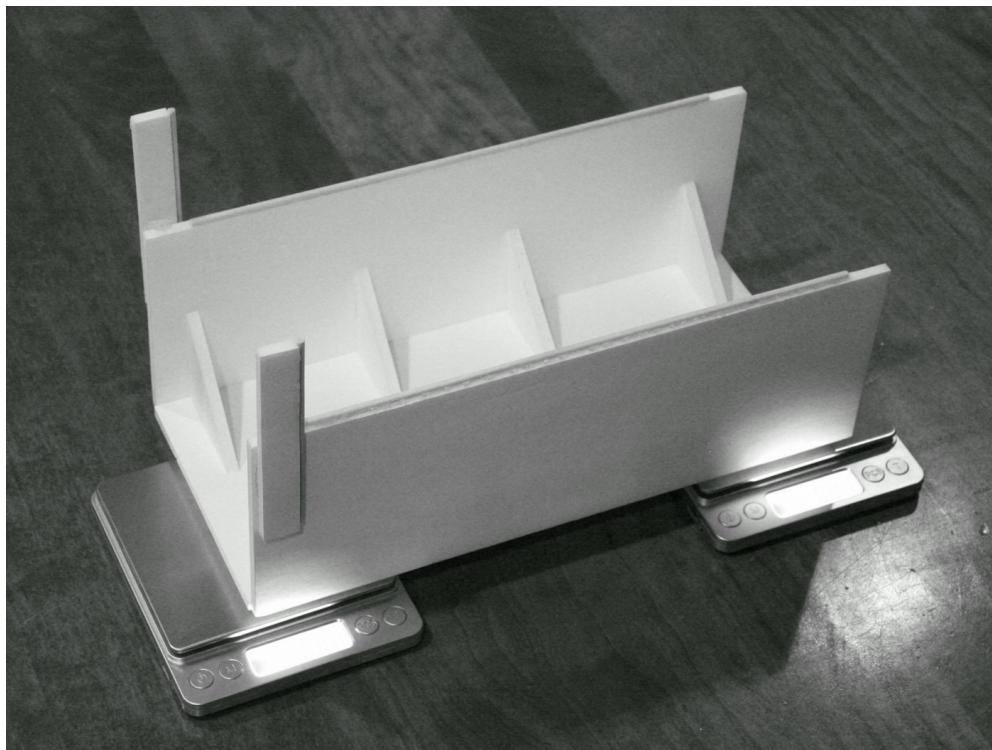

fig. 20 The completed CG frame + scales

## Measuring CG With Your New Scale

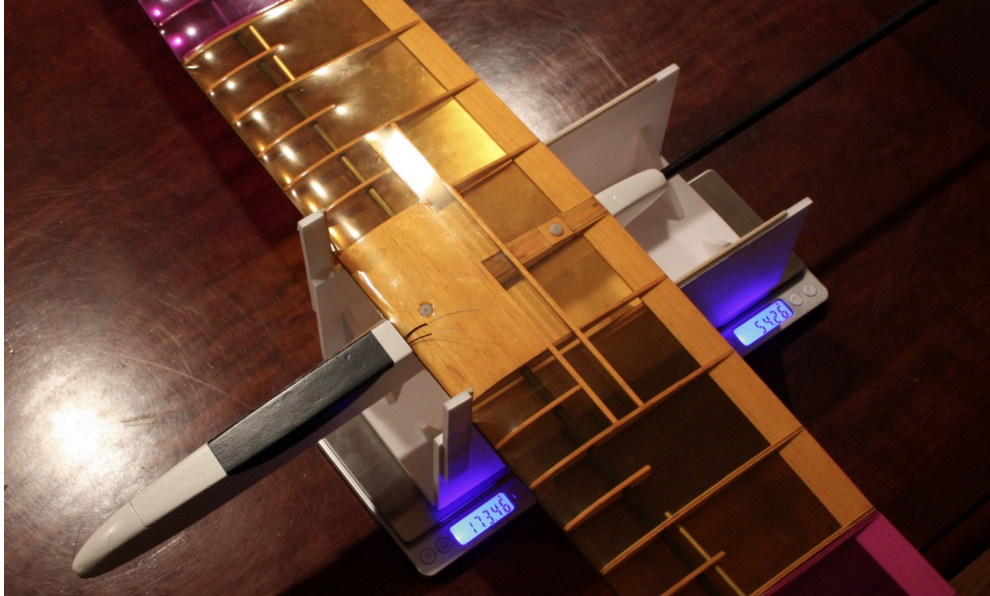

fig. 21 1.5m Yellow Jacket F3RES on the scale.

Using the scale is quick and easy to do:

- Place the empty frame onto the scales and use the tare (T) function to zero them out.
- Place the model onto the frame with the leading edge forward and touching the stops.
- Wait for the scales to settle, then take the  $w^1$  and  $w^2$  readings.

With the known distance between the scale contact points  $a$  and  $b$  of 240mm, plug the values into the simple formula  $(w^2 * \ell) \div (w^1 + w^2)$  to get the CG. In the example, this F3RES model has a CG of 57.2mm from the wing leading edge (see *Resources* below for calc spreadsheet).

$$(54.3g * 240mm) \div (173.5g + 54.3g) = 57.2mm$$

I've tested this design with a range of models including a Dream-Flight *Alula*, 1.5m *Yellow Jacket F3RES*, 2m *Radian* and 3.5m *F5J Supra* and the results have been exceedingly accurate – on the order of +/- 0.5mm as checked against a commercial unit and manual balance points on the bench. Larger F5J models might benefit by simply

scaling up the plans somewhat and perhaps doubling the frame walls to handle the added weight.

©2022

## Resources

- [CG Calculation Spreadsheets](#) – In both Microsoft *Excel* and MacOS *Numbers* formats. Note that with most browsers the download will start automatically and will put the file in your *Downloads* folder.
- [Trimming Model Aircraft](#) by Peter Scott for the May, 2022 issue of the *New RC Soaring Digest*. – “We wouldn’t drive a car that drifted across the centre of the road. We wouldn’t ride a bike at speed that had a warped wheel. We shouldn’t fly our models that are not trimmed correctly...”
- [F3X CG Scale](#) by Olav Kallhovd on GitHub. – “Arduino based Open Source CG scale for F3X gliders (and other model airplanes) The scale can be used for most modern F3F/F3B gliders with slim fuselages and will calculate the CG and weight...”
- [Foamboard](#) from R.L. Adams Plastics and branded as *Readi-Board*. However, your local stationery store will have something equivalent even if you can’t find the Adams’ product.
- [Scale with 500g max, 0.01g resolution – \\$16.99](#) on Amazon. Note that these are just examples which exemplify the specs required. Of course, you may find equivalents closer to home and/or at a better price.

---

## Building the Rico-SHE LW

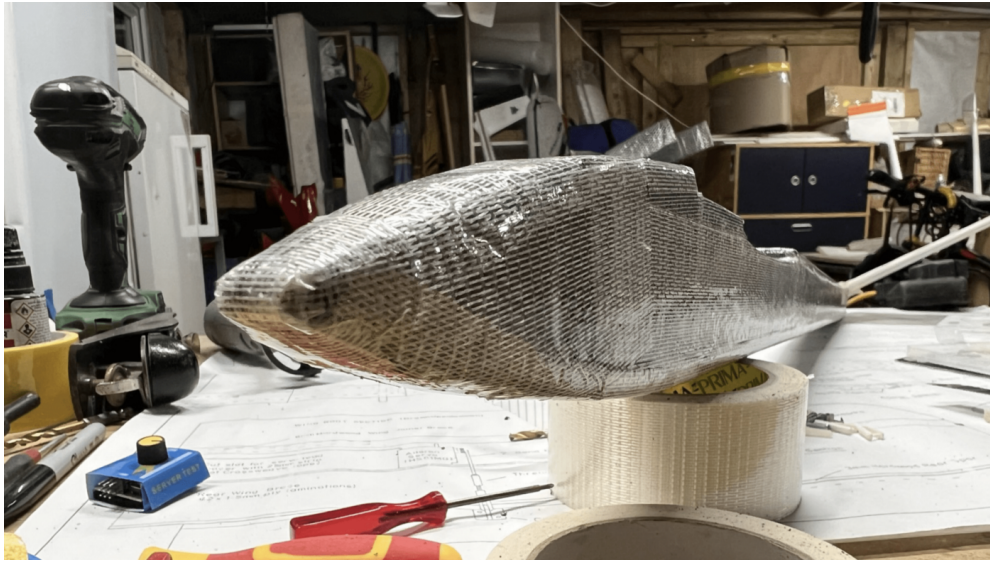

Wild Scotch salmon wrapped and ready from Tesco? No, it's the Rico-SHE LW with its nose in place, shaped and taped. Read on for an explanation as to how you get to this point!

### ***Part I: The Lightweight Version of the Classic Racer from Phoenix Model Products***

A slightly different build this time: A 60" pylon racer / sports slope soarer in EPP foam and wood from Phoenix Model Products (PMP – see *Resources* for link) and designed by Stan Yeo. Yes, slope pylon racing is a thing – or it was, no idea if it is still. I'm sure someone will comment! *(By the way, we're pretty sure it's pronounced 'ricochet' which it hopefully **won't** do too often. – Ed.)*



Rico-SHE (credit: Phoenix Model Products)

As with most formula racing, the resulting designs tend to have certain similarities. A quick look at PMP's site shows there are plenty of 60" pylon designs (and many others, he's quite prolific!) I've seen a few on the slope in the flesh and acquired another prebuilt one a few years back – the *Enigma* – but I've never built one myself.



My PMP Enigma came with me on holiday to Rhodes, Greece.

Fast forward to early summer and an email popped up from a club member: "For sale various gliders and kits..." Amongst them were two that caught my eye: A 'kit' (fuselage and wings) *Sitar* special and this *Rico-SHE* kit. Some funds were exchanged, and I have two more added to the build list, the 1st of which is discussed here today.

## When Is a Foamie Not A Foamie?

One of the selling points of the PMP kits is that they are a quick build and they 'bounce'. But this is not your normal ARF foamie! Inside the foam exterior, there's a wooden structure. Model building techniques are still needed: the plans call for reinforcement as you build.

**NB.** I'm sure you have seen the many, many YouTube videos showing you how to 'lamfilm' your store bought Foamie? No need with this one. You do it as you build (and its stronger!).

## What's in The Kit?

Pretty much everything you need to build a 60" glider, just add glue and covering materials:

- The EPP wing panels (RG15 section) come pre-cut in two sections, with rebates top and bottom for the spars and ply joiner.
- The Corex tailplane is cut to shape and just needs creasing and hinging.
- The wooden skeleton that makes up the fuselage inside the foam is accurately pre-cut too.
- All the 'bits' you'd need were in my box too: the square and triangle sections to make the skeleton, the spars and joiner, the control arms, rods and clevises too.

The three pages of building instructions (see *Resources*) while not picture heavy, are comprehensive enough to make this a straightforward build, logically flowing and without cul-de-sacs. They



suggest an 8 hour “hands on” time frame. That’s about what I have put in.

**NB.** There’s ‘glue time’ to add to that, YMMV.

What else do I need? Add to the kit the ‘usual’ modelling stuff you probably have in the workshop already: cyanoacrylate (CA) glue, kicker, Evo-Stik Impact adhesive, Gorilla / polyurethane (PU) glue, cutting tools, masking tape, covering materials etc.

## Let’s Build

The starting point is the fuselage box section which runs the length of the airframe and to which the foam outer skin will attach. My kit is for the ‘Light Weight’ or LW version†, so my first task was to glue in some doublers, followed by some internal longerons and spacers. Glue choice: Titebond 3 wood glue on the doublers / longerons and medium CA for the spacers.

**NB.** †The LW version has thinner box walls @ 0.8mm vs the 1.5mm of the normal version. The wing root area is doubled on the LW version.

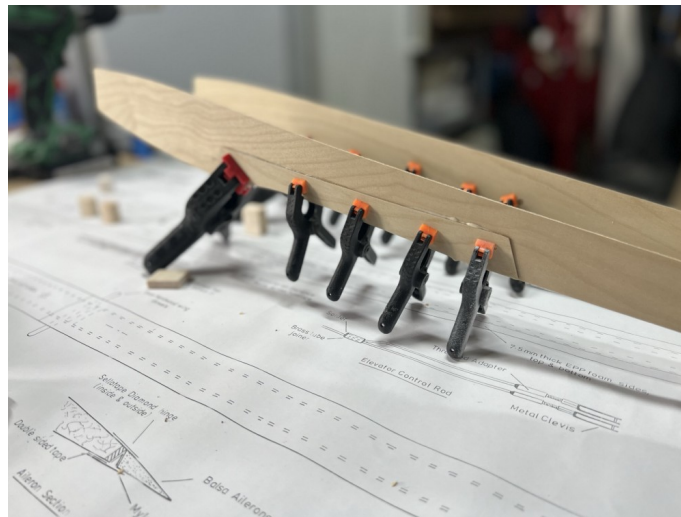

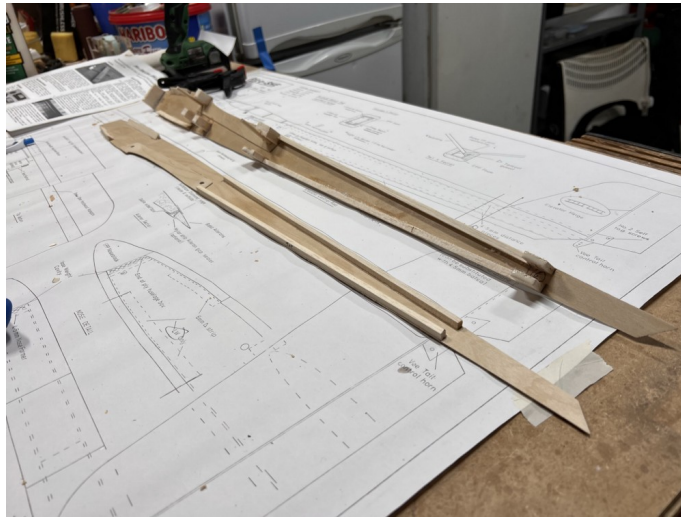

Doublers under the wing root. Longerons and spacers glued into place.

With the internals of the fuselage in place, the two sides can be joined, using the wing retaining dowels to aid alignment and clamped in place while the Titebond does its thing. Helpfully, the dowel points are pre-marked from the factory, just drill to open.

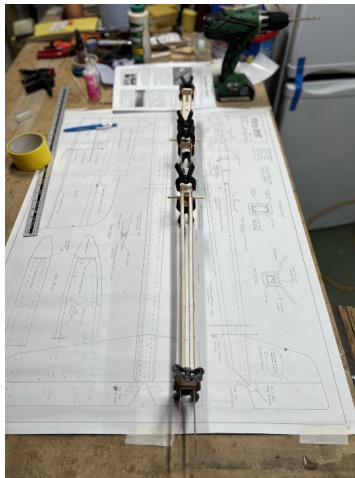



Gluing the fuselage sides — needs to be straight! (It is, but the camera is distorting it!)

## A Distraction

While the fuselage was curing, I started on the wing spars. These are simple hardwood strips that run full span, top and bottom. A little refinement was needed to get a good snug fit — the hotwire used to cut the cores isn't accurate enough to get a perfect fit, so they are cut undersized. A few minutes work with some 180 grit paper resulted a good, tight fit, ready for the spars and PU glue.

Once the top spars were glued and cleaned up (the PU glue will foam up and seep out!) the trailing edge spars were attached.



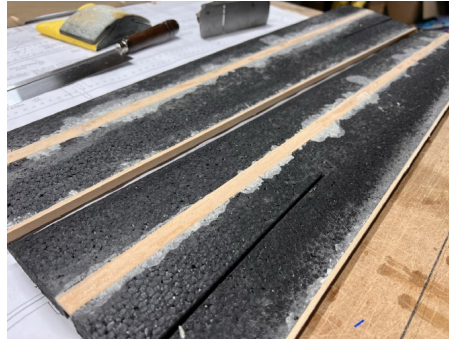

Dry fit, spars fitted, TE gluing, done.

With top and trailing edge (TE) spars in place, the panels are flipped over for the lower spars. At the same time, the two panels also need to be joined (it's a one-piece wing) with the main ply joiner and a smaller secondary towards the rear of the wing. The secondary is a laminate of 1.5mm ply.

## Meanwhile, in the Fuselage Department

The *Rico-SHE* is an aileron / elevator aircraft, of the 'bank and yank' style of turn coordination 😊. Therefore, the only servo that goes inside the fuselage is for the elevator, driving a forked control rod. The kit comes with a brass collar to join the long rod and its smaller fork, but I chose to solder (and clamp) mine rather than just clamp the collar. The instructions are pretty good at describing the process to mount and cut to length the rods etc, so no issues there!

With the servo rods done, the fuselage top and bottom decks can be added. Initially, I used PU glue, but for the latter, I used medium CA. You will see later on the fuselage is wrapped in foam and then reinforced tape and an outer covering. The box section is structural,

but there's not much torsion or shear on the joints, so I think CA should be fine.

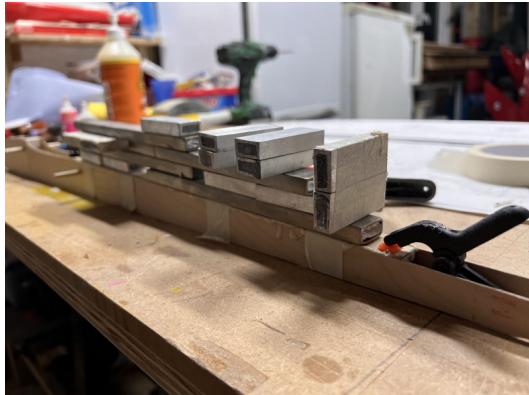
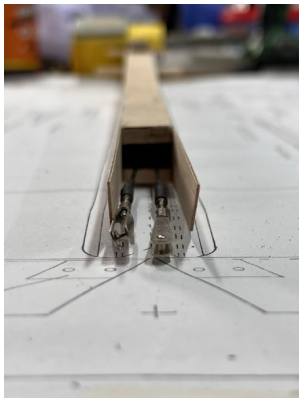
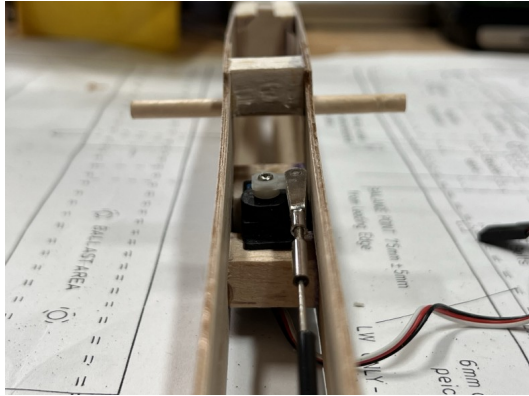

Some 'spare' F3F ballast lending a hand while the deck glue sets up.

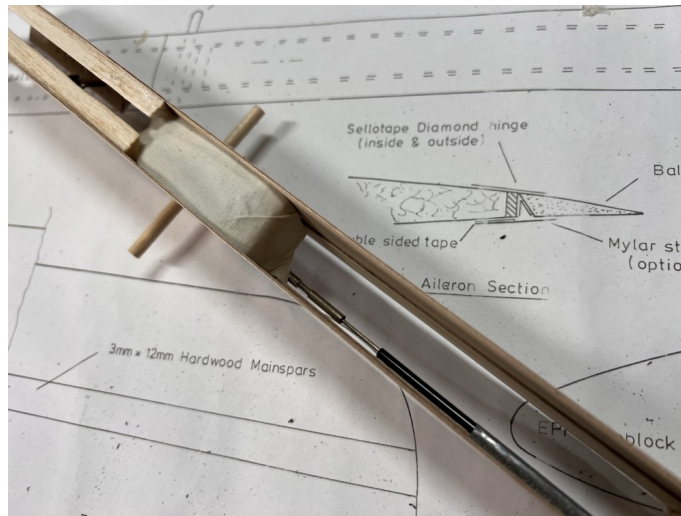
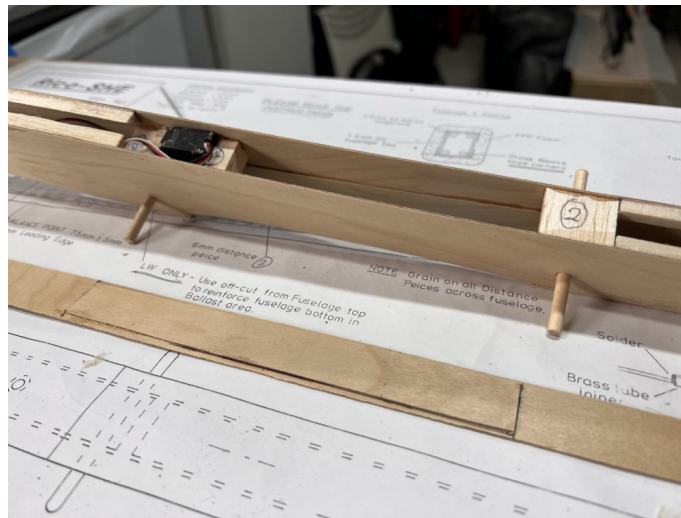

Dry fit servo, build the control rods. Glue the decks in place, protect the servo from glue over run.



Admire your work so far with a quick table fly.

## Remember, This Is A Foamie

Now that we have a wooden box section or skeleton, we need to make it a foamie. The kit is supplied with oversized strips of EPP foam which I glued into place with Evo-Stik Impact adhesive. The order is sides first, followed by top and bottom deck second. After each is attached, the overhang is removed resulting in an overlapped square, wrapping the box section.

By happy accident (okay, it's per the plan, but it is very smart!) there's a small empty section on the nose where you need to fit 60g of nose weight. It fits perfectly! Almost like it was designed that way! 😊



Setup, coat with glue, wait for the "dry" stage, weight down and then trim.

---



All 4 sides done, note the overlap. 60g of weight added.

## Back to The Wings

The servo pockets were transferred from the plans to the wing cores and then routed out using the Dremel and the router jig I wrote about in *What a Tool! Servo Templates for Dremel Rotary Tools* (see *Resources*).

**NB.** This differs slightly from the plans: They call for a full cut through the wing panel and then a back fill with offcut foam. There's no need with the Dremel and the jig.

Once the pockets are cut, the wings are covered with cross weave (CW) tape, overlapping about 10mm per run. I also added a second longitudinal strip of CW tape on the other side of the servo pockets to reinforce the (now) thinner area of the wing.

---





Mark the location of the servo pockets, rout them out with a Dremel and a jig.

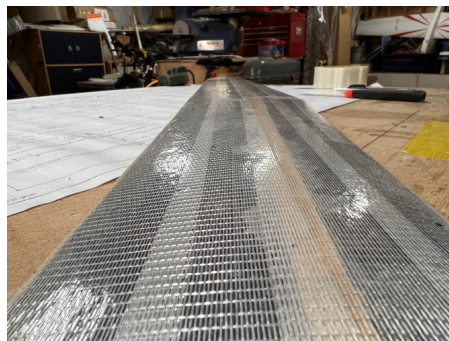



Cross weave tape, overlapped about 10mm

## Tail End Of Things

By this stage, it's starting to look a lot like a glider, but it still needs a tail. The kit is supplied with materials for a Corex V-tail. An alternative would be to make something from balsa, but for me, the Corex is sufficient. A few minutes with a ruler and a craft knife results in a perfectly proportioned tailplane, ready for control horns and mounting.

The tail is held in place with an assortment of triangular sections of balsa (all pre-shaped in the kit), glued into the gap between the two fuselage sides. I used a mix of PU and Impact adhesive depending on the surface and if there were any gaps to fill.

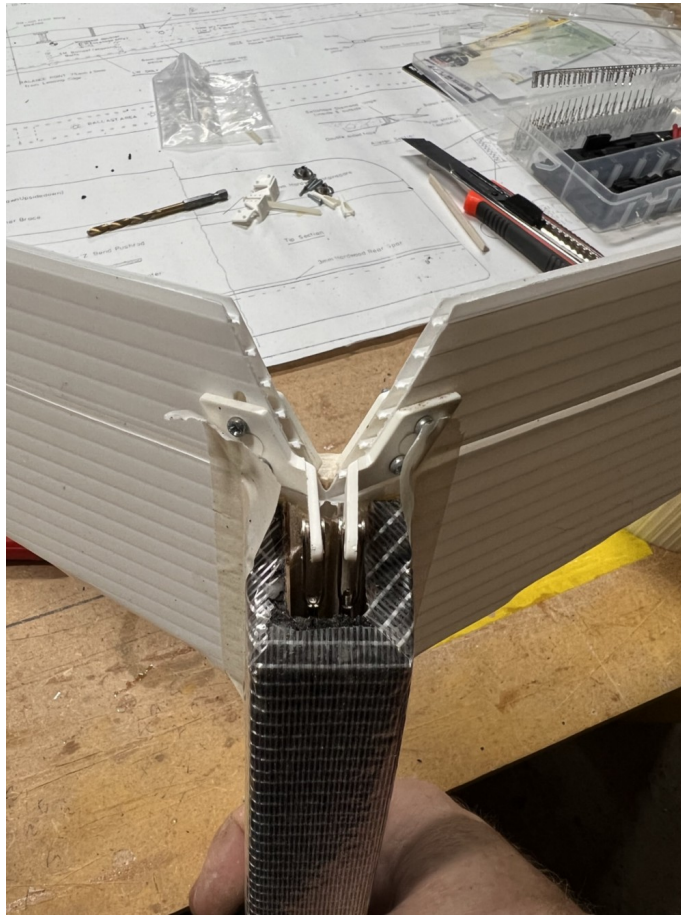

Control arms fitted and adjusted; equal throws confirmed. Time for a quick table fly.

## Get To The Point

With 60g of weight in a handy vertical pocket up front, the aerodynamics are not ideal. The kit has an answer to this though and it's a separate lump of foam, pre-cut to a rounded 'nose'. PU glue to the rescue and as you can see above, the rough shaped nose is in place.

As with other steps, the foam is easily worked with a mix of sharp craft knives or 180 grit sandpaper. It didn't take long to get the rough shape refined down to a 'sportier' glider nose, with flowing lines back to the rest of the fuselage. It too was then taped over with cross weave.

## Next Time

- Ailerons: shape & mount
- Coverings: might be vinyl, might be packing tape (the traditional covering)
- Radio fit: one for my new FrSky X18
- To the slope!

## Rhönadler 35



### Part II: Into the Tender Hands Of Gravity

*While this article stands well on its own, some readers may want to read [Part I: Design and Construction](#) to catch up on the story so far. Also, as with the previous story you can click any image for a full resolution version. — Ed.*

So, time rolled on, as it does, and thoughts turned to the task of putting theory into the tender hands of gravity.



Experience with the larger version of the Rhönadler gave a good indication of what to expect once the Day of the Maiden arrived so onwards and, hopefully, upwards.

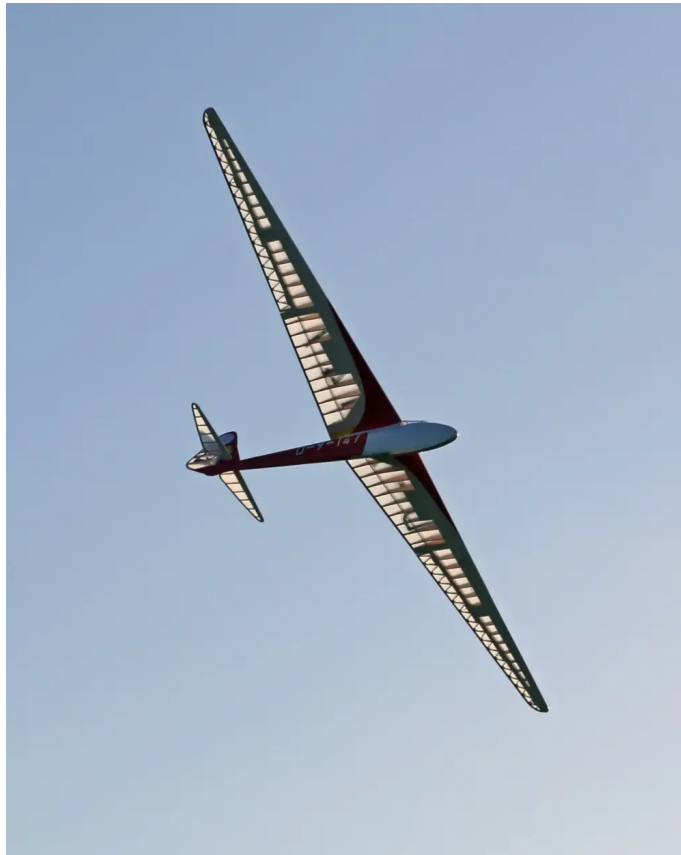

To recap: in a departure from my normal arrangement, this model features a very thick scale wing section at the root, transitioning to my normal HQ section at the tip at a mere 12% thickness.



Once hooked up behind Smallpiece's tug and towed to altitude, it became obvious that the new model performed much like the old one, but on steroids. This translates to a very stately performance (translation: scale-like) with a long, floaty approach when it's time to land.





With the ailerons mixed to come up with the spoilers, glide path control is reassuringly robust, and despite the thick wing root, penetration into a breeze is not problematic.



Don't just take my word for the foregoing though – you can see for yourself in my *Riding with Ronnie* video, linked immediately below.

©2022

## Resources

- [Riding with Ronnie](#) – YouTube video where **both** video and soundtrack music are by the author and features “the reduced-scale Rhönadler 35 in action at White Sheet Hill...”

## Also by the Author

- [The Williams Anthology](#) The collected works of the author as presented on the pages of the *New RC Soaring Digest*.

*All images by the author. Read the [next article](#) in this issue, return to the [previous article](#) in this issue or go to the [table of contents](#). A PDF version of this article, or the entire issue, is available [upon request](#).*

1

1

## The Slingsby King Kite



Wing set vertically and smeared with white glue ready in anticipation of the sheeting.

### Part V: Tricky Ailerons, Wing Sheeting and Fuselage Fairing

*This is the fifth part of a six part series. Readers may want to the review [previous parts](#) before proceeding with this article.*

In the drawing, the aileron seemed to consist of two parts, of which nothing could be found in the photos of the real thing. I therefore decided not to divide it in two parts. Another problem was that the aileron was enclosed on both sides. I therefore chose the same hinges as the horizontal stabilizer; thus the aileron remained removable, as with the horizontal stabilizer.

After cutting off the aileron from the wing, I realized how long and narrow it was – 115cm long and 4.5cm wide. Unfortunately the airfoil choice did not help either as the aileron was only 6–7mm thick. I became convinced that I had to control the aileron in two places and luckily was able to find a place for an extra servo in the wing.

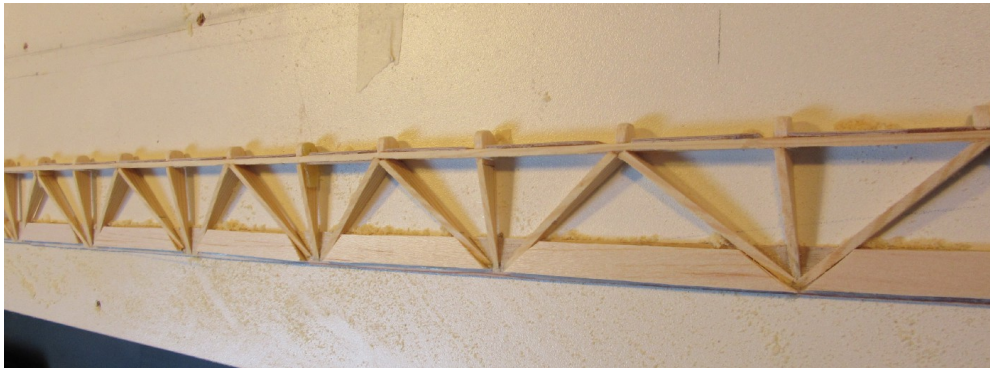

Aileron cut off, it needs reinforcement!

The balsa ribs in the aileron were very thin and fragile so I replaced them all with 2mm solid spruce, took out one, replaced it with spruce, went on to the next, so I kept the dimensions correct.

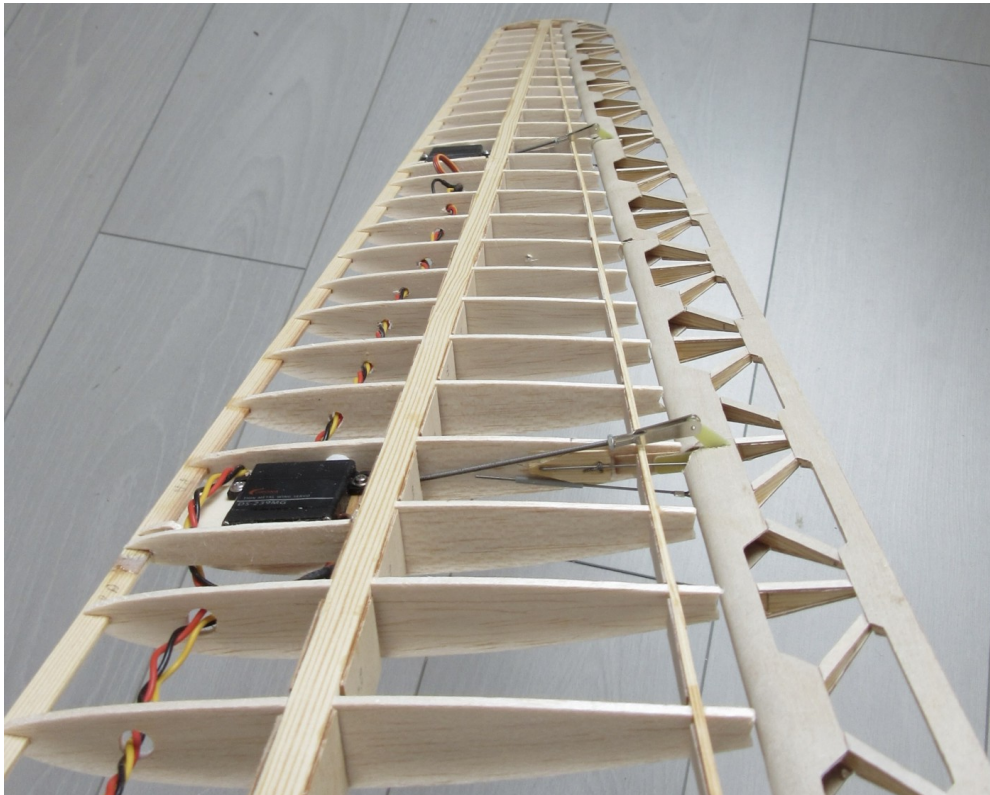

Two servos per aileron.

I wanted to make a plywood D-section for the nose of the aileron. With boiling water I bent U profiles of 0.6 plywood around a 6mm tube and let them dry. I slid the aileron skeleton into this profile and clamped it between a board and a batten. With tape on all surfaces to prevent it all getting glued up. I also built in some twisting. I set it upright and dripped thin cyano between the rib skeleton and the plywood U profile. Now it became much firmer. The trailing edge (TE) is also a sandwich

from 0.6mm plywood and balsa. Then I cut and sanded the U profile and the TE into shape. After adding the capstrips and some more sanding, the aileron was roughly finished.

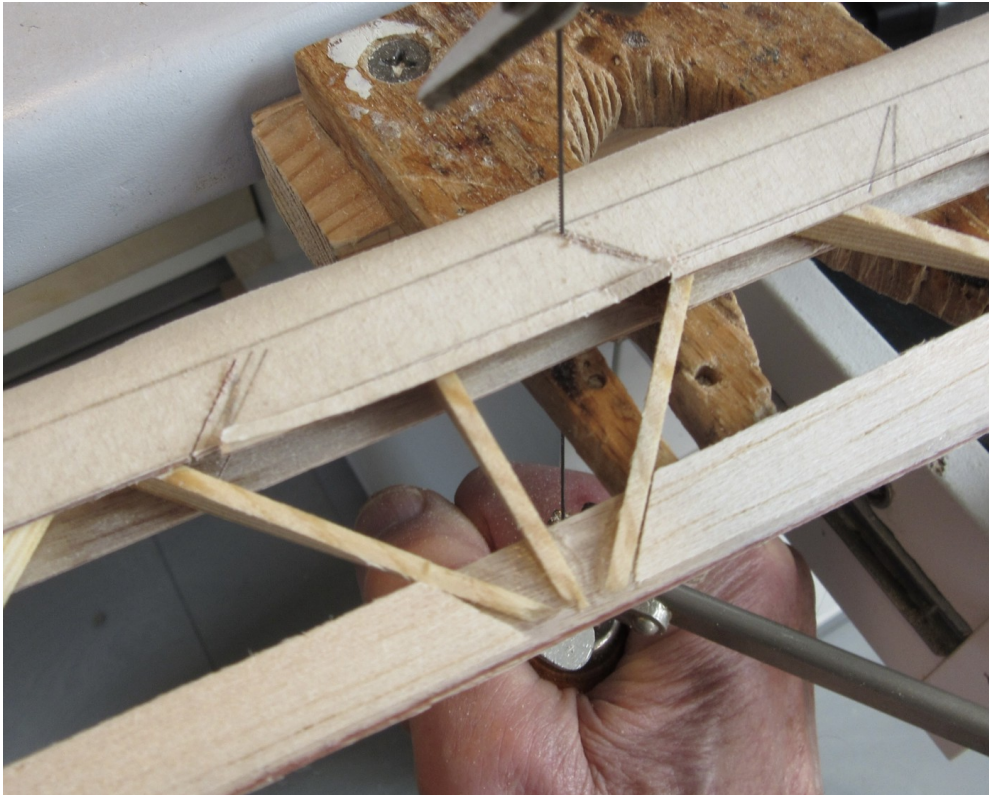

The nose of the aileron just covered with a wide pre-bent strip, the 'gusset' plates are cut out with a jigsaw.

After finishing the second aileron, I went on with the flaps. These were much shorter (56cm) than the ailerons and completely sheeted. They were even thinner than the ailerons, less than 6mm thick so I liked to sheet them in one go.

I took a strip of 9cm wide, 0.6mm plywood, and bent it around a 6mm round rod, whilst pouring it over with boiling water. See also the video *Bending 0.6mm Ply Across the Grain* (linked in *Resources* below) for additional information in this regard. Then I clamped and let it dry.



Wing sheeting ply pre-bent with boiling water.

I fitted the skeleton (consisting of spar and ribs) into the folded plywood and now I could mark, cut and sand the plywood. The bottom of the structure was covered with PVA and clamped with a 10x10mm batten and strips of 4mm ply. After the glue had dried I could fold the plywood 'open' and drilled holes 1mm from the inside pilot so that the openings at the hinges and rudderhorn could be made later. The top of the ribs were smeared with glue and the whole thing was clamped together. With a Dremel I made openings for the hinges and after some adjustments it fitted neatly into the wing.



Pressing the wing sheeting onto the wet glue and removing it again to smooth out the glue with a wet finger. See also the key photo above the title of this article.

I intended to keep the operation of the ailerons and flaps simple; this time not with pull-pull wires, as with the *Gull*. The pull-pull cables in the wings are complicated and there is a bit more friction which is not good for the centring. I thought to make a pull-push rod on the bottom and a dummy control on the top. Unfortunately I couldn't figure out how the flaps were operated, so I also chose a pull-push rod on the bottom.

Based on what I saw on a photo I estimated the size of the rudderhorns. I came up with very small horns, I drew them twice too big (by hand). And again I found my friend Adri Brand willing to CNC quite a few. Afterwards the size seemed quite fitting.

The dummy control at the top of the wing was made from 0.8mm steel wire, with a non-functional clip. This rod could move freely in a plastic tube glued to a rib. I made the functioning pull-push rod from an M2 threaded rod with quick links. To remove the aileron – to put the *Diacov* on – I disconnected the quicklinks, unlocked the hinge pins and then could detach the aileron, dummy rods and all. The flaps

only had pull-push rod at the bottom, I made these from 1mm steel wire with a guide tube against bending. After some soldering I could now check the operating of flaps and ailerons and they worked nicely.

The wings roughly finished, I could now make the fairing. The original had a gap between wing and fuselage of about 10cm; just big enough to mount the wings. After assembly a strip of plywood went over it and I wanted to make it similar.

In the fairing, the grain of the plywood had to run the length of the wing and thus be bent transversely to the grain. Again, see the video linked below for more information on the bending procedure.

After bending the plywood was left to dry, shortened at one side (some length was needed for bending) and then cut off pieces. I started with the TE, narrow pieces, bevelled with a Proxxon power file, with which those tiny pieces can be subtly shaped. They are glued to the end rib and fuselage with thick cyano. Where the curvature in the end rib decreases, I could also take longer pieces. With something long and round I could press the pieces in place while the cyano sets. Sometimes it went wrong and I had to take out a piece. The gap to the wing would be covered by a detachable plywood thing so I had to do the sheeting of the wing first.

I always find it difficult to sheet the D-section of the wing with ply. I enjoyed gluing by semi-dried PVA and heating with a foil iron, but was unable to bend the plywood sharply enough with water and a hot foil iron. This was also due to the profile's sharp nose. An additional problem being the panels having to be skewed to keep the seam parallel to the longitudinal axis. For that reason I tried to pre-bend the panels, as with the aileron, with boiling water and then let them dry. Afterwards they could be made to fit and be sanded a bevel on it. To prevent cramped fingers I made an attachment: a thin aluminium profile fastened to the worktop with a G-clamp and covered with sandpaper for anti-slip.



I smeared both surfaces to be glued with PVA. The glue had to be spread out still. After drying I put such a panel in its place, it could still be adjusted and then heated with a foil iron to set the glue. The bend in the gull wing was also succeeded with two narrow panels and so it began looking like a wing!

Because the wings are completely sheeted, there are a lot of panels, glued with the same technique, dried PVA and fixed with a foil iron. I had doubts about how that could be stuck to the balsa ribs and thought I should apply twice as much PVA on them. Now the wing was still 'open' I could apply some extra glue, but once the top was on, that would no longer be possible.

The completely covered wing now looked robust. Next, I had to shorten the rear of the ply for the ailerons and flaps. I had already shortened the lower ply before applying the upper one, by drilling a few 1mm pilot holes flush with the hinge pins and cutting the plywood along those holes.



Sanding aid.

Of course, there was still some sanding to be done. The ailerons and flaps remained removable just like the stabiliser. A quick try out to see if everything worked properly, which luckily it did.

The wings were now ready and weighed 936g and 942g respectively.



Ready for staining and varnishing.

The connection of the wing to the fuselage was going to be different from what I was used to. The gap between fuselage and wing was covered with a curved strip of plywood. The wing itself is secured with a nylon M3 bolt in plywood lips to the fuselage and wing.

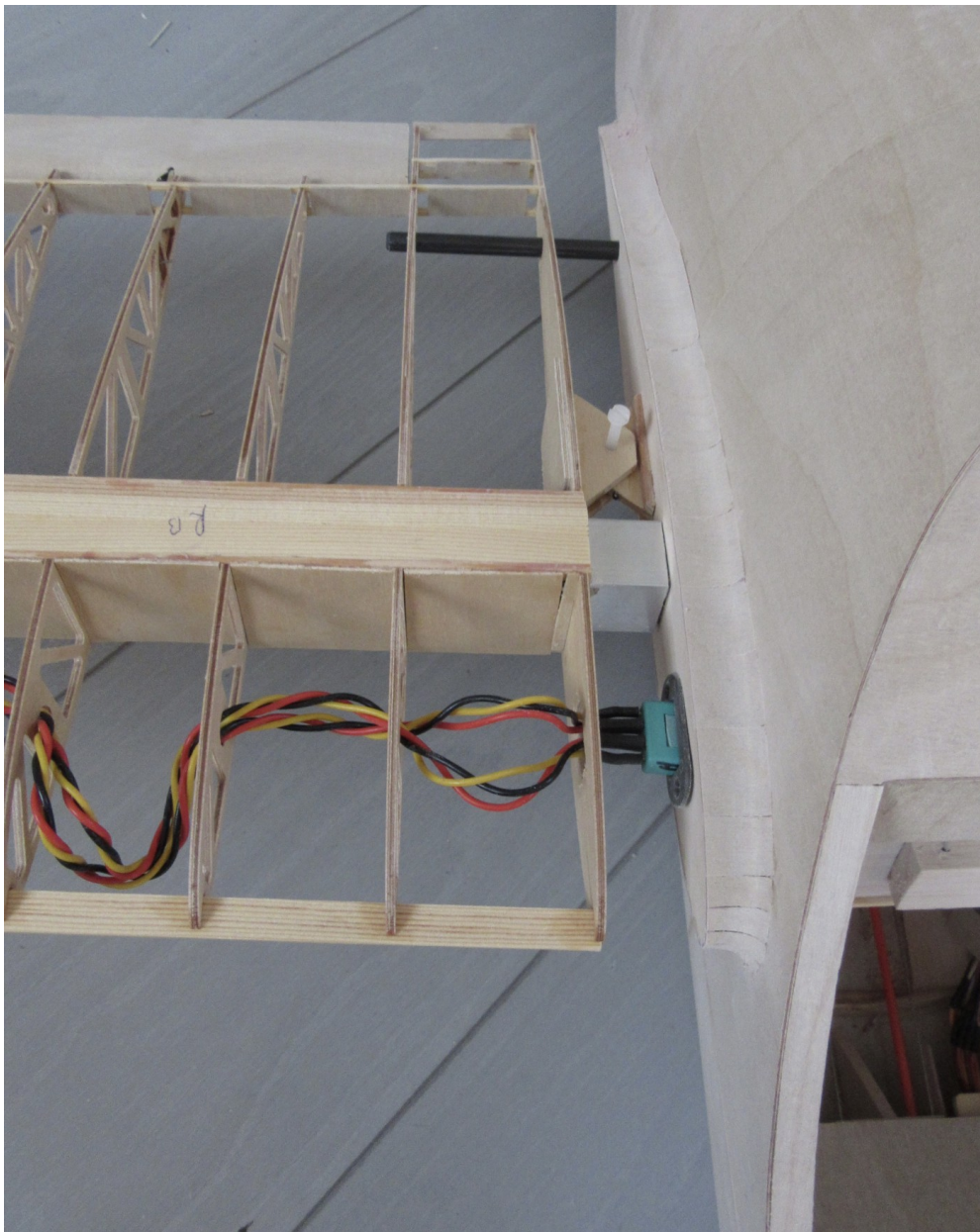

Connection to the fuselage, secured with a nylon M3 bolt. Over the wide gap, just like the real one, a removable strip is placed.

To cover the gap, I made a piece of balsa plywood sandwich for it, which could be slid over the wing from the front, secured with a magnet and a piece of clear tape for safety. Suddenly it looked like a glider! To finish it, the ply was stained with bister, a water based, organic brown colour. Then two layers of dope with some *Porienvuller* (see *Resources*) and one layer boat varnish were applied and the ailerons and tailplanes sheeted with *Diacov* (see *Resources*).

Next month I wrap up the construction and then it's on to the fun part – flying! See you next time and thanks for reading.



## Science for Model Flyers



Periodic Table of Elements at Nagoya City Science Museum. (credit: そらみみ under Attribution-Share Alike 4.0 International)

### Part I: The Periodic Table

You have had time to recover from *Electricity for Model Flyers* (see Resources, below). Now I am going to show you how science permeates our hobby. ‘Modern’ science has been around for a surprisingly long time and the stories are worth reading. I will be including some thumb nail sketches about the scientists and some experiments for you to try to help the ideas sink in. The first of this series is a look at one of the oldest and most fundamental of all modern scientific ideas, the periodic table.

### Please Be Kind

I hope professional chemists and materials scientists don’t take issue with my explanations. I have attempted to explain simply without telling untruths. That said, please let me know of any mistakes and suggested additions or improvements by leaving a *Response* to this article or contacting me at my website (see *Resources*, below). I love

to learn. The full details of the various types of battery have very complex chemistries far beyond this article.

## Time to Lift Off

The periodic table is a brilliant insight, fully clarified by Dmitri Mendeleev in 1869. The table was almost perfect science – a model that fitted the known facts and could be used to make predictions that later were proved to be true. It is important to us as flyers as it explains:

- conductivity
- radio transmission
- battery chemistry
- navigation light colours
- silicon's importance for electronic chips
- possible dangers from the materials we use
- why we must have gold plating on our connectors
- why we should top up electrolytes when climbing slopes on a hot day
- what to do if we are in a full size electric 'plane about to ditch in the sea

## The Periodic Table

Look at the periodic table in Picture 1, which adorns a wall in most labs. We see all of the ninety-two naturally occurring stable elements up to uranium. In Mendeleev's time only fifty-six were known. There were gaps in the table but the surrounding elements enabled scientists to predict the atomic weight and many of the physical properties of the missing elements. People knew what to look for and when they had found it.

Beyond uranium, and called transuranic, there are now more elements made artificially by us. Amongst many other things the table now tells us about an element are the number of electrons it has and how the

electrons are arranged. Even if we fly using internal combustion power the rest of our models use electricity and that is what electrons are.

Let me again stress that the diagrams and explanations used by scientists are analogies or models. We get closest to reality in the mathematical formulae and even there we are using symbols to represent the underlying ideas. Every model has its limits and breaks down at some point. However this doesn't mean the ideas it represents are wrong. It is just a way of helping our limited mammalian brain to grasp the idea. In the end, as Newton said, 'If it works mathematically that is enough.' (Remember *satis est?*)

To illustrate our limitations, as a teenager I once lay in bed (don't they all!) trying to imagine infinite space. I used the model of empty space going on for ever. I was doing well, imagining bigger and bigger when all of a sudden my brain just shut down. My hundred thousand million brain cells proved insufficient and refused in a sulky way to think about it any more. Of course Einstein gave us a get out. He insisted that space was curved so you will eventually get back to where you started. Space is infinite but bounded. Read Dr Seuss' story, 'The Big Brag', for an example.

**PERIODIC TABLE OF THE ELEMENTS**

1	2											13	14	15	16	17	18																
1	H Hydrogen 1.008											3	B Boron 10.811	4	C Carbon 12.011	5	N Nitrogen 14.007	6	O Oxygen 15.999	7	F Fluorine 18.998	8	Ne Neon 20.180										
2	3	4											13	14	15	16	17	18															
2	Li Lithium 6.941	4	Be Beryllium 9.012											13	Al Aluminum 26.982	14	Si Silicon 28.086	15	P Phosphorus 30.974	16	S Sulfur 32.065	17	Cl Chlorine 35.453	18	Ar Argon 39.948								
3	11	12											13	14	15	16	17	18															
3	Na Sodium 22.990	12	Mg Magnesium 24.305											13	Al Aluminum 26.982	14	Si Silicon 28.086	15	P Phosphorus 30.974	16	S Sulfur 32.065	17	Cl Chlorine 35.453	18	Ar Argon 39.948								
4	19	20	21	22	23	24	25	26	27	28	29	30	31	32	33	34	35	36															
4	K Potassium 39.098	Ca Calcium 40.078	Sc Scandium 44.956	Ti Titanium 47.88	V Vanadium 50.942	Cr Chromium 51.996	Mn Manganese 54.938	Fe Iron 55.845	Co Cobalt 58.933	Ni Nickel 58.693	Cu Copper 63.546	Zn Zinc 65.38	Ga Gallium 69.723	Ge Germanium 72.631	As Arsenic 74.922	Se Selenium 78.972	Br Bromine 79.904	Kr Krypton 83.798															
5	37	38	39	40	41	42	43	44	45	46	47	48	49	50	51	52	53	54															
5	Rb Rubidium 85.468	Sr Strontium 87.62	Y Yttrium 88.906	Zr Zirconium 91.224	Nb Niobium 92.906	Mo Molybdenum 95.95	Tc Technetium 98.907	Ru Ruthenium 101.07	Rh Rhodium 102.906	Pd Palladium 106.42	Ag Silver 107.868	Cd Cadmium 112.414	In Indium 114.818	Sn Tin 118.711	Sb Antimony 121.760	Te Tellurium 127.6	I Iodine 126.904	Xe Xenon 131.294															
6	55	56	57-71	72	73	74	75	76	77	78	79	80	81	82	83	84	85	86															
6	Cs Cesium 132.905	Ba Barium 137.328		Hf Hafnium 178.49	Ta Tantalum 180.948	W Tungsten 183.85	Re Rhenium 186.207	Os Osmium 190.23	Ir Iridium 192.22	Pt Platinum 195.08	Au Gold 196.967	Hg Mercury 200.59	Tl Thallium 204.383	Pb Lead 207.2	Bi Bismuth 208.980	Po Polonium (209)	At Astatine 209	Rn Radon 222.018															
7	87	88	89-103	104	105	106	107	108	109	110	111	112	113	114	115	116	117	118															
7	Fr Francium 223	Ra Radium 226		Rf Rutherfordium (261)	Db Dubnium (262)	Sg Seaborgium (263)	Bh Bohrium (264)	Hs Hassium (265)	Mt Meitnerium (266)	Ds Darmstadtium (267)	Rg Roentgenium (268)	Cn Copernicium (284)	Nh Nihonium (285)	Fl Flerovium (286)	Mc Moscovium (287)	Lv Livermorium (288)	Ts Tennessine (294)	Og Oganesson (294)															
																			57	58	59	60	61	62	63	64	65	66	67	68	69	70	71
																			La Lanthanum 138.905	Ce Cerium 140.116	Pr Praseodymium 140.908	Nd Neodymium 144.242	Pm Promethium 144.913	Sm Samarium 150.36	Eu Europium 151.964	Gd Gadolinium 157.25	Tb Terbium 158.925	Dy Dysprosium 162.500	Ho Holmium 164.930	Er Erbium 167.259	Tm Thulium 168.934	Yb Ytterbium 173.055	Lu Lutetium 174.967
																			89	90	91	92	93	94	95	96	97	98	99	100	101	102	103
																			Ac Actinium 227	Th Thorium 232	Pa Protactinium 231	U Uranium 238	Np Neptunium 237	Pu Plutonium 244	Am Americium 243	Cm Curium 247	Bk Berkelium 247	Cf Californium 251	Es Einsteinium 254	Fm Fermium 257	Md Mendelevium 258	No Nobelium 259	Lr Lawrencium 262
																			Alkali Metal	Alkaline Earth	Transition Metal	Basic Metal	Metalloid	Nonmetal	Halogen	Noble Gas	Lanthanide	Actinide					

Picture 1 (credit: Todd Helmenstine via Science Notes)

Dmitri Mendeleev 1834–1907

Mendeleev was born in Siberia. His mother came from a family of merchants and publishers. His father was the head of a school and taught arts, politics and philosophy. How he finished up with his names is odd as any reader of Russian literature will tell you it always seems to be. The best translators include a glossary of names so you can keep track as the various versions are used for each person. His father eventually settled on the name Mendeleev after the name of a local landlord. Dmitri was the youngest of seventeen children of whom fourteen survived.

The family suffered financial disasters so they moved first to Moscow then to St Petersburg to get an education for Dmitri. After a spell in the Crimea recovering from tuberculosis, and a spell in Heidelberg working on capillary action and spectroscopy, he returned to St Petersburg. His work there, including his design of the periodic table, made it a world centre for chemistry.

## Rare Earth Metals (REMs)

Also called Rare Earth Elements (REEs) these seventeen elements are of crucial importance both to us as humans and as model flyers. Look at the table above. Below the main body of the table are two rows. The upper one is called the lanthanides. These are fifteen of the REMs. In addition there are two more, Scandium and Yttrium, also called REMs because they have similar properties. In naming these elements Sweden gets a lion's share. Four elements names are based on the Swedish village Ytterby where they were first extracted. In addition Scandium is named for the the area.

The strangeness of the name rare earth is due to history. They are neither rare nor an earth. They are found all over the world, and are often found together. Originally they were called 'earths' because they are non-ferrous metals. However they are rare in the sense that they have a very low concentration in the mined ore. This means that extraction is energy intensive and polluting, so tends to happen in



poor countries where local people have little say or are desperate for any kind of income.

REMs are at the heart of modern technologies. Amongst other things they are used in lasers, magnets, electronic components, jet engine alloys, special glass, superconductors and LEDs. I even have tooth crowns made of yttrium mixed with zirconium.

## Atoms

An atom has a small and very dense centre, called a nucleus, containing neutrons and protons, collectively called hadrons. The number of protons determines what element it is and its atomic number in the table. The total of neutrons and protons determine its mass. An atom is written like this (Picture 2):

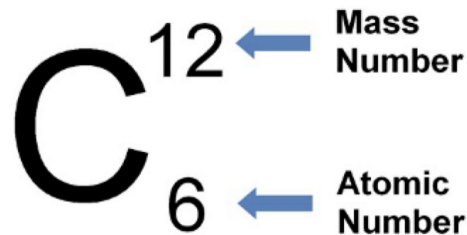

Picture 2

This tells us that the element carbon has six protons (atomic number) and six neutrons making twelve nuclear particles in total (atomic mass number). It also tells us that it has six electrons, of which, as you will see later, four are free to form links with other atoms.

The nucleus is very small compared with the size of the atom having a radius about 1/2000 of the total radius of the atom. For Brits this is like an acorn on the end of Nelson's nose where his column in Trafalgar Square is the atom's radius. The Statue of Liberty is nearly twice as tall from the ground so I suppose a horsechestnut would be about right for size.

And now a personal dislike. I usually avoid bothering about other people's pronunciation but one that always bugs me is noo-kewler instead of new-clear when pronouncing 'nuclear'.

With all this empty space how can things feel solid? It is because the electrons are in a cloud surrounding the nucleus. They are kept circling by the attraction between the positive nucleus and the negative electrons. When we touch something solid the outer electrons in our fingers are strongly repelled by the outer electrons of the thing we are touching. An analogy is a spinning propellor. There is a slight chance that you might get your finger through but it is pretty certain that it will be chopped off.

The simplest elements, hydrogen (1 proton and 1 electron) and helium (2 protons 2 neutrons and 2 electrons), are found in normal glowing stars. Once the universe cooled enough from the big bang for atoms to form, hydrogen was the only atom around. The hydrogen clouds were collapsed by gravity into stars and as their potential energy turned into kinetic energy they heated up. The high temperature meant that the hydrogen atoms were smashed together at a high speed so their nuclei fused to form helium. This fusion gave off even more heat and is the technology used in hydrogen bombs. This was the moment when stars lit up for the first time. I loved the adverts from one sunglasses maker that boasted, 'Thermonuclear Protection.' We hope to use this process in fusion reactors to generate heat to make electricity as it produces no long lived or harmful pollution and the fuel is everywhere. However for the last sixty years delivery has always been 'in about thirty years' and still is. One day our batteries might be charged with fusion electricity but don't hold your breath.

## **Stardust**

So where do all the other elements come from? Stars eventually burn up most of their hydrogen fuel, then cool down and start to collapse under gravity. They didn't collapse before because the violent movement and collisions of the hot atoms held them out against gravity. What happens then depends on how large and massive the star is. 'Massive' here has its true meaning of 'amount of mass'. We are learning rapidly about the life stories of stars of different masses

and it makes a fascinating read. If in your country you can get the British Broadcasting Corporation's (BBC) Radio 4 programme 'In Our Time' on the Sounds app or as a podcast, there was an excellent account of stars on June 9th 2022. Knowledge is advancing very fast so don't bother to read anything more than a year or two old. The wonderful Hubble telescope has given us so much new information and it is a great relief that the new James Webb has not been damaged by the recent particle strike.

For very massive stars, collapse can provide enough heat energy to fuse helium and hydrogen atoms into heavier elements up to iron. Many stars go through cycles of collapse and expansion, heating and cooling, which produce these elements. Others collapse so far they squeeze out some or all of the space that the electrons are in and become in effect one big nucleus, called a neutron star or white dwarf. Some are so massive and dense that they become black holes. White dwarfs are very dense, a cubic centimetre having a mass of perhaps 1 metric tonne. Neutron stars are  $10^8$  times denser. The squeezing is so great that the electrons and protons are squashed together to make the neutrons. According to wikipedia one teaspoon of a neutron star has the same mass as the Great Pyramid at Giza.

Stars are often found in pairs that circle each other, called binary stars. The more massive one can drag matter from the lighter one so changing both lives, or they can collide. If two neutron stars merge they can create a huge unstable object that explodes in what is called a 'super-nova'. Such events provide the vast energy needed to fuse elements further to make the very heavy ones like gold. These events are relatively rare in the chaos of the universe but there is so much of it that we have traces of gold on our planet sufficient to back up our economies, adorn ourselves with jewellery and most important to plate our radio control connectors and boards. And of course to provide us with Aussie Gold Hunters.

The explosions scatter the elements far and wide and they later form new stars. Quite often the matter for the new star is spinning around a

centre of gravity and some of the matter doesn't fall into the star but remains surrounding it. This matter collapses into planets and satellites which continue to orbit the new star. Exactly how that happens is under investigation with evidence from ever larger telescopes. All kinds of hypotheses are suggested with exotic names like The Nice Model, Late Heavy Bombardment, Dust Clumps and Pebble Accretion. It looks likely that as with stars there are several routes for the evolution of planets. The address for an excellent Quanta Magazine article is at the end.

Some planets allow life to evolve. Recent studies of matter from a comet has found amino acids from which life is made. Did you know that the name vitamin – a chemical essential for life – comes from 'vital amine'? We are stardust – literally – exactly as Joni Mitchell sang. And when we die our atoms spread out again. Nothing is wasted nor lost.

One odd but true fact that is not relevant here but gives a feeling for the the large numbers involved is that, every time you breathe in, the air includes at least one molecule from Plato's dying breath, or anyone else you choose. There are roughly as many air particles in a half-litre tidal breath as there are half-litres in the entire breathable atmosphere.

## Shells and Exclusion

Back from the stars to our world. In one atom each electron has energy that we visualise using the analogy of concentric layers, called shells. They aren't layers of course, being just different energy states, but it works well as an analogy – a model. Each shell has a letter and a maximum number of electrons in it. There is one shell for each row in the periodic table and an energy state inside that shell for each electron. In his 'Exclusion Principle' Wolfgang Pauli told us that in an atom each electron must have its own energy state different from the others.

Let us look at the three innermost shells. These are the top three rows on the periodic table. The innermost shell, named K, can only contain two electrons and the other two, named L and M, can contain up to eight. So there are two, eight and eight elements in these first three rows. (M can hold 18 for heavier elements.) Each time we step across the columns of the table the number of protons in the nucleus increases by one. This is called the atomic number and determines what element it is. The number of electrons in the outermost shell also goes up by one. To be exact this is only true when the atom is well separated from others and in its lowest energy state as you will see later.

### **Wolfgang Pauli 1900–1958**

Pauli was born in Vienna to a chemist father and had Ernst Mach, of Mach Number fame, as a godfather. He emerged as a great mind early in life. He was what scientists aspire to be, an internationalist. He studied and worked in many countries including the US and over his short life was a citizen of three countries, his native Austria, the United States, then Switzerland. His grandparents were from a leading Jewish family in Prague. He was brought up as a Roman Catholic but later renounced that. He was not immune to mystical ideas as he became a friend and disciple of Carl Jung, though a critical one.

One early work was a lengthy critique of relativity, which Einstein himself praised. However he is best known for his work on quantum mechanics. He proposed the idea of electron energy levels including spin and the exclusion principle which governs the way electrons are structured in terms of energy states. He worked in Gottingen, Copenhagen, Hamburg, Zurich, Michigan and Princeton in the US. He died young in Zurich of pancreatic cancer.

## **Columns and Properties**

Now we can use the periodic table model to explain things. The elements in a column, also called a group, have similar properties. In the first column group there is one electron in the outer shell of the elements, that can easily be pulled out. This makes those elements very reactive. Look at the names: hydrogen, lithium and sodium. At school you probably saw a lump of sodium dropped into water. It reacts with the water, heats up, melts into a ball, skitters around on the layer of steam on the water surface then explodes. Great fun. Sodium, which is a soft metal and shiny when cut with a knife, must be stored in oil. Lithium behaves much the same but less so. All of the elements in that column are highly reactive. That is important for our batteries.

In the next column group the elements are still reactive but less so. As we move to the right across the table the reactivity drops. As we go vertically down a column the reactivity increases.

The last but one column group contains reactive elements called halogens. It is a unique group in that it contains elements that are solid (iodine), liquid (bromine) or gas (chlorine) at room temperature. Fluorine, chlorine and bromine react with the chemicals of the human body and so are very poisonous or dangerous. Chlorine is used as chemical weapon, for example in Syria, and polytetrafluoroethylene (PTFE or teflon) will give off fluorine if overheated, for example by machining or drilling. Other plastics also can give off fumes so it pays to open your workshop door and window when shaping them. A simple cloth mask won't protect you against gases. The halogens are reactive as they have one vacant energy level in their outer shells. They are different in that they are less reactive as you move down the column. Fluorine is the most reactive. Hydrofluoric is the most powerful acid and can dissolve glass so is used to etch patterns on it. It has to be stored in rubber or plastic containers and is very dangerous to living flesh as it goes in and dissolves bones and can cause heart failure. On the Internet there are gruesome pictures of its effect.

Then we reach the last column group. The gas elements here have a full outer shell. This makes it difficult to add or remove electrons so these are very unreactive elements, usually called inert or noble. Again look at the names. Stable neon and xenon are used for gas discharge lights such as advertising displays and camera flash lights. Argon is used as an unreactive shield against oxygen in the air for argon-arc welding and as an inert, heavy gas inside double-glazed window units.

The elements in the middle of the table are mostly metals. When atoms are in a solid crystal form, electrons are more loosely attached to them and can easily be shared with other atoms. They are called 'free electrons' and behave a bit like a gas in a pipe making the materials electrical conductors. More about that later.

## Quanta and Radiation

When we add energy to an atom it usually only raises the energy of the electrons. They move to higher shells or energy levels. When they drop back to a lower level they radiate the energy. This might be in the form of light, heat, radio waves etc. These are all electromagnetic (EM) waves which are the subject of another article. The strange thing is that only certain jumps between two allowed energy states are possible, each called a quantum. The radiation is both waves and particles, the latter being called photons. The bigger the quantum jump, the more energy the photon has and the higher its frequency. That is why when heated some metals first glow red, then orange, then yellow and finally white when all the colours are emitted. It is also why the colour of lamp bulbs is often given as a temperature. Pure white ones are 6500 K (kelvin), which is the temperature of the outside of the sun and is described as 'daylight white'. 2500 to 3000 K is called 'warm white' similar to an old, cooler tungsten filament lamp. When we heat metals we use the colours to tell us the temperature. We are seeing the light from ever larger energy jumps. It's why some less massive stars go from white to red as they age and cool down,

as our sun will before long. Well actually in four thousand million years so you can put that bottom of your list of things to worry about.

Newton suggested that light was particles, which was thought very funny at the time. Thomas Young suggested that it was waves which seemed to match observed data better. However it turned out that they were both right. EM radiation is a wave when moving but if you stop it, so you know where it is, the wave collapses into a photon particle. This is called Heisenberg's Uncertainty Principle. You can know radiation's speed or its position but not both at the same time. And of course when emitted from an atom by an electron energy jump it starts as a particle, a photon. So our radio control signals are the result of quanta of a particular size produced by electron jumps. Young's biographical thumbnail is in the article on aerials.

## Energy in Electrons

Where electrons are concerned energy is measured in electron volts eV. This is a tiny amount and is the energy that one electron has when raised to one volt. That compares with the SI unit for energy, the joule, which is the energy of one coulomb of charge raised to one volt ( $1\text{ C} = 6.2 \times 10^{18}$  electrons). Max Planck showed that when an electron releases its energy the number of eV determines the frequency of the radiation, and hence its colour if it is visible. As an example, the 1.8 eV jump in gallium arsenide phosphide gives a red photon, which is why that material glows red as a light emitting diode (LED). So the port navigation light on your scale model gives out 1.8 eV photons many, many times. Many. Many. The more current that flows the more electrons there are to make the jump and emit a photon. That is why more current means more brightness. The size of the eV jumps needed for different colours is why LEDs have different voltage drops.

Examples of materials used in LEDs and the colours they produce are shown in Figure 1.



Material	Wavelength (nm)	Colour	Photon Energy (eV)
GaAs	850 - 940	Infra-red	1.2
GaAsP	630 - 690	Red	1.8
GaAsP	605 - 620	Orange	2.0
GaAsP:N	585 - 595	Yellow	2.2
AlGaP	550 - 570	Green	3.5
SiC	430 - 505	Blue	3.6
InGaN	450	White	4.0

Figure 1: Ga – gallium, As – arsenic, P – phosphorus, Al – aluminium, Si – silicon, C – Carbon, In – indium, GaN – gallium nitride.

## Flashing Lights

You might have noticed when you move your eyes rapidly from side to side when looking at an LED that you get a row of individual flashes. The brightness of LEDs can go up and down very quickly with little energy loss. There is no metal filament to heat up nor gas to start glowing. To save energy LEDs are often rapidly switched on and off with the brightness being decided by on versus off time as well as by the current. Usually our eyes don't notice the flashing. The switching speed is one reason for the great data speeds in fibre optic communication cables that will be carrying this article at least part of the way. One gigabit/s would be impossible without the fast LEDs used to carry the data.

### Max Planck (1858–1947)

He was born in Holstein in 1858 which was then part of Denmark. Planck's family was well educated with professors, lawyers and a judge. Holstein was annexed by what became Germany, in a messy war not unlike Ukraine now. Lord Palmerston, then the British Prime Minister, is reputed to have said, 'Only three individuals knew the cause of the tangled dispute. One was Prince Albert, who

unfortunately was dead; the second was a Danish official who had gone mad; and the third was he himself, Lord Palmerston, who had forgotten it.'

After graduating at 17, Planck could have been a talented musician. Instead he opted for Physics, against the advice of a Munich professor, who said 'In this field [Physics], almost everything is already discovered, and all that remains is to fill a few holes.' Professors! What do they know?

After several other posts he ended as Professor at Berlin University. In 1918 he won the Nobel Prize for Physics for his work in quantum physics. In 1945 his favourite son Erwin was killed for his part in an attempt to kill Hitler.

## Band Theory

When atoms join together to form other substances they share some of their electrons, called valency. It is the sharing that holds them together, like the sentimental clichés about human relationships. Pauli said that each electron must have its own unique energy state.

When there are many atoms close to each other the levels for the electrons must increase in number, so they form bands of allowed states with gaps between the bands called energy gaps and measured in eV as shown in Picture 3. The electrons can move around. Provided the outer band is not full this forms conductors.

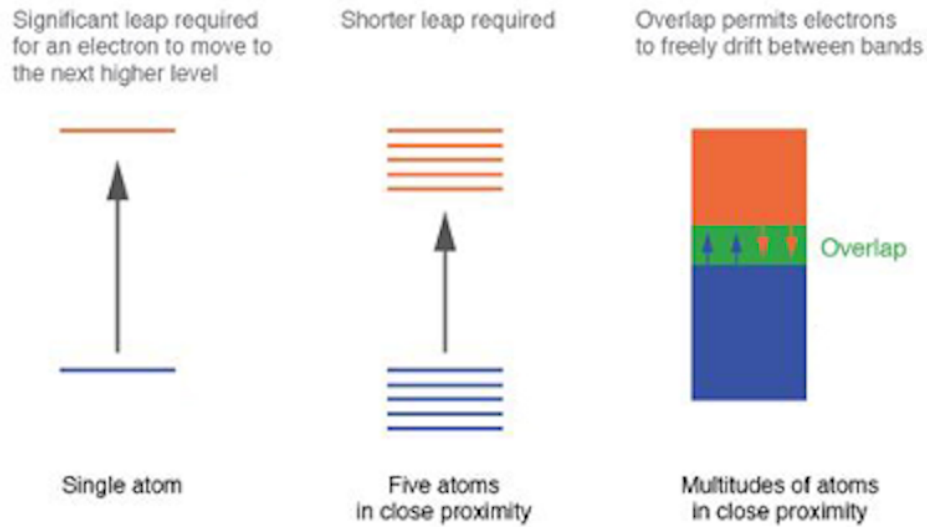

Picture 3

This is called Band Theory, though here the word theory is used in its proper sense of 'law that works' not the ill-informed sense of, 'Scientists don't really know. It's only a theory.'

## Conductors, Insulators and Semi-Conductors

Apart from the outermost conduction band all lower bands will be full. The next one down is called the valence band and we need not trouble about the others. The energy gap between the conduction and valence bands is one reason for how conductive a substance is. The other is how full the conduction band is.

In semi-conductors the energy gap is narrow. In silicon it is between 0.5 to 1.1 eV. As the material is made hotter electrons can jump this gap into the conduction band so the resistance falls. This is shown in Picture 4.

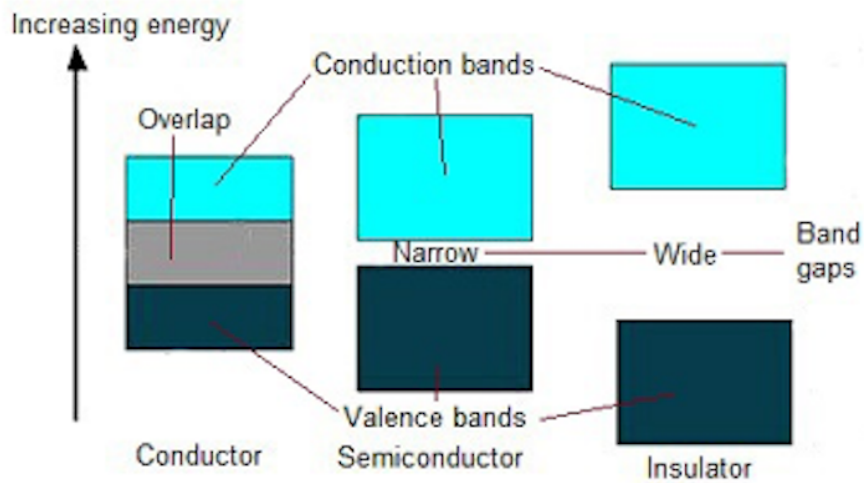

Picture 4

## Crystals

A crystal is a solid that is made up of a three dimensional lattice of atoms. You see this in natural crystalline rocks where a perfect crystal will have flat faces, perfectly straight edges and a set of angles that is the same throughout. The way the atoms pack together determine the angles. Most are not like the perfect 90° format we will use later. Common table salt is, which is why it forms cube crystals.

Copper sulphate is shown in Picture 5. It hasn't been ground or cut to look like this.



Picture 5 (credit: ty-penguin.org.uk)

This is only true for perfectly pure materials. If an impurity is added, which I will call doping from now on, the doping atoms will be of a different size and/or valency and will mess up the perfect structure. By doing this in a controlled way, with the doping atoms well spaced out, we can alter the conduction and build integrated circuits (IC, chips) by adding new energy levels. Incidentally doping can also change the colour of the crystal by messing with the crystal structure.

To make electronic integrated circuits (ICs) large crystals of silicon, called ingots, are grown by slowly drawing them out of a tank of liquid silicon. This ensures that the crystal structure is perfect. One is shown in Picture 6. They are then sliced into round wafers and polished. The silicon in the wafers is called a substrate. Then the surface is doped with a range of different elements after photographically masking off the areas to be doped with each dopant in turn. That way circuits can be built up with components that are nanometres in size. For example the latest 2 nm chips have parts on them that are 1/40 000 of the thickness of an average human hair.

There are many rectangular chips on one wafer. The wafer is scored with a diamond just like glass, which of course is what it is. Then the small chips are broken apart and connected into packages using fine gold wires that are welded on. That's where our radio equipment and servo chips come from. And of course the mobile phone you use to say you'll be late home from flying.



Picture 6: A silicon ingot. (credit: Solar Market Pty. Ltd.)

In picture 7 you see one 300 mm wafer showing a grid of integrated circuits (chips). The coloured spectra are caused by light waves

reflected from the tiny patterns on the circuits.

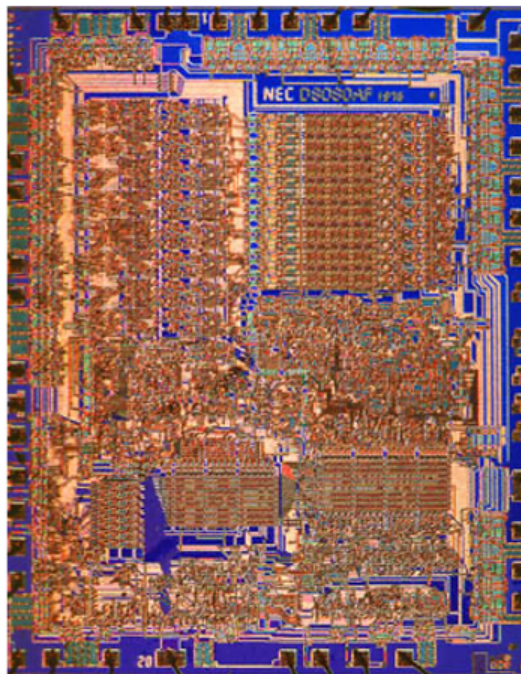
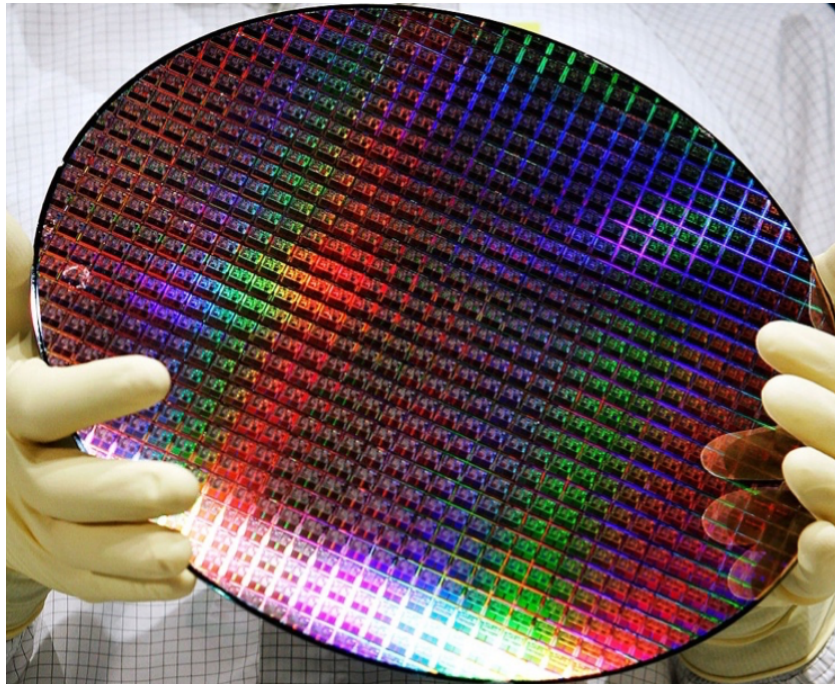

Picture 7 (left): A 300mm wafer showing a grid of integrated circuits. (credit: iTech Post) | Picture 8 (right): And just one chip, separated from the grid. (credit: National High Magnetic Field Laboratory)

## Experiment One: Growing a Crystal

You might have grown crystals at school where a solution slowly evaporates and deposits crystals on a string or in a container. Copper

sulphate, alum or even table salt or sugar can be grown like that. Check the health and safety sheets on the internet for the materials you decide to use unless it is salt or sugar. If any are hazardous make sure you understand the risks, wear gloves and do not touch your eyes or mouth. There are lots of instructions and kits listed on the internet. One excellent example is on the Instructables site listed at the end.

Most methods will just give you a mass of small crystals. It is possible, though difficult, to grow a single large crystal. The trick is to hang a thread or piece of fishing line from a pencil or tongue depressor across the top of glass jar. Put a strong cold solution of your chosen material into the jar. Carry on stirring until no more will dissolve. The amount will surprise you. Filter the solution. You can get a funnel and papers from the supplier of the chemicals or use a kitchen funnel and a fine cloth. Tie a single small crystal on the end of the string and let it dangle in the solution near to the bottom but with enough clearance for the crystal to grow. Cover the jar loosely so the liquid can evaporate but dust can't fall in. Then wait for days or weeks. The first try might not work so dissolve the material and try again. With luck you will grow one or more largish crystals. With even more luck you might have a single separate one. However attractive they look take care not to let children handle them with bare hands.

## Doping

Doping allows us to fiddle with how materials conduct. Our integrated circuits or chips are made from materials where the band structure is changed by doping with other elements. In semiconductors the doping adds new levels in the narrow energy gap so the electrons behave differently. The silicon substrate can be changed to form circuits on its surface. The doping atoms are kept far apart so they do not form bands. If the energy level is close to the conduction band electrons can jump into the conduction band as additional negatives so the extra moving charges are negative and the material is called n-type. If the level is close to the valence band electrons leaving the

band leave positive holes so the material is p-type having positives that move by electrons jumping in them from another atom.

- Valency 4 materials are used for the substrate: silicon and previously germanium
- Valency 5 materials are used for n-type doping: phosphorus, antimony, bismuth
- Valency 3 materials are used for p-type doping: indium, thallium, gallium, boron

There are two ways of picturing semiconductor doping, that is by band theory and by crystal structure. If you can see how they are connected you have just completed your freshman year in Physics or Materials Science. Note that in the band diagrams the word impurity is used instead of doping.

## N-type phosphorus doping

Phosphorus can share five electrons with other atoms. Silicon can only share four. There is a surplus electron free for conduction. The mobile charges are negative, which is why this conductor is called n-type. In Picture 9 we see how it looks on the crystal structure diagram. The structure of the crystal is not as right-angular as this.

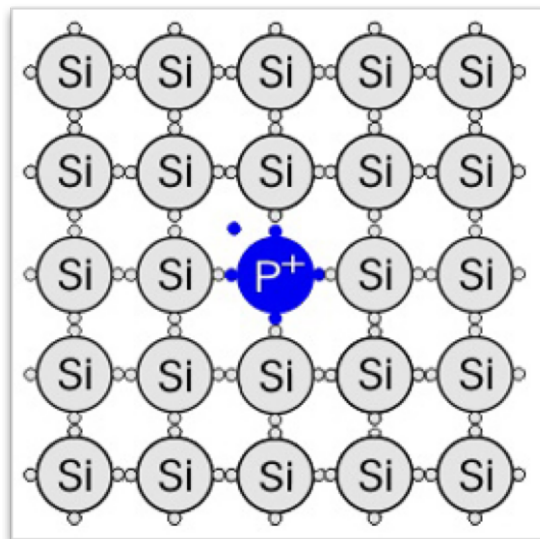



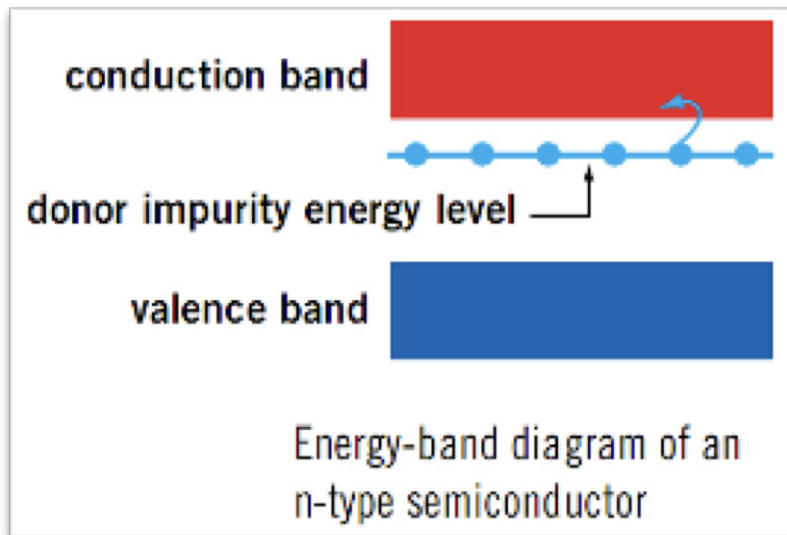

Picture 9 (left): Crystal structure diagram. | Picture 10 (right): The band diagram.

## P-Type Boron Doping

Boron can share three electrons. In effect there is a positive hole in the valency structure where there should be an electron. So an electron moves to fill it and the hole moves in the opposite direction. There is no surplus of electrons, so in effect the mobile charges (holes) are positive giving the material the name p-type, shown in Pictures 11 and 12.

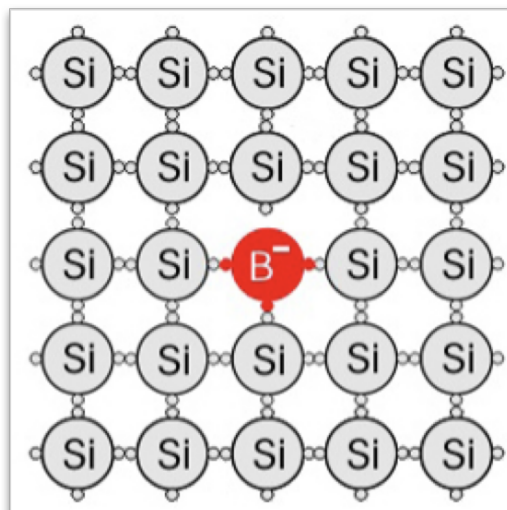

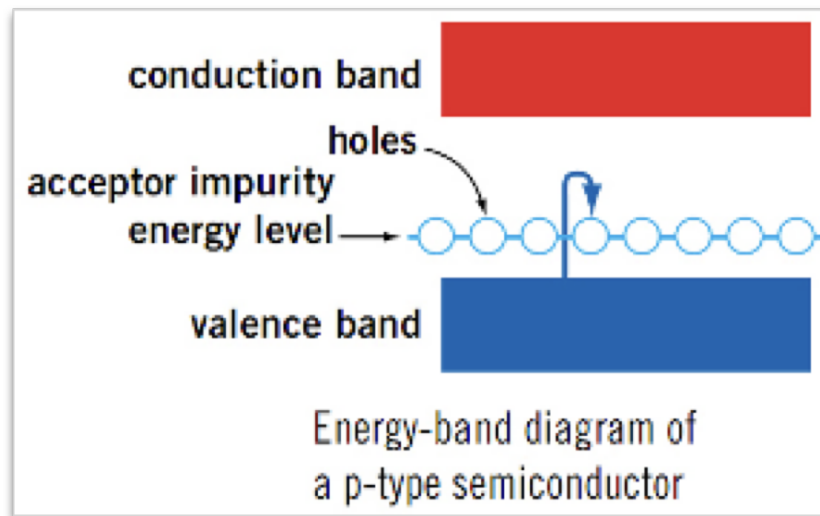

Picture 11 (left) | Picture 12 (right)

## Atoms, Ions and Molecules

A lone atom with no extra energy is electrically neutral, having equal numbers of electrons and protons. If one or more electrons are removed from an atom it becomes positive, called oxidation, and if added it becomes negative called reduction. Such charged atoms are then called ions.

When atoms link together by exchanging electrons it is called a chemical reaction and a new substance is formed, the combined substance being called a compound. The dual process of gain and loss during a reaction is called a redox reaction (reduction-oxidation). The particles are now called molecules. The properties can change dramatically. After all a deadly green gas (chlorine) and a highly flammable metal (sodium) come together to make crystals to sprinkle on our chips (fries). In effect the atoms share one or more electrons, called valency. The number of valency electrons decides how many other atoms it can link with. The angles of the links decide what three-dimensional shape the resulting molecule will have.

Atoms that share one, two, three, four and five electrons are called univalent, bivalent, trivalent, quadrivalent, and pentavalent. The fact that carbon is quadrivalent (or tetravalent) is the main reason why it is the backbone of life and all other organic substances. The four

valences and the fact that they are at wide angles to each other means that long chains of carbon atoms can be formed as a backbone to large molecules and that complex three dimensional molecules can be built. So you, and the birds that follow your gliders, exist to fly because of carbon's valency. The existence of carbon throughout the universe makes it highly likely that life exists elsewhere and might even prove to be a natural progression. Let's hope aliens are all as genial as ET. In fiction aliens are usually shown as more advanced than us. Some scientists suggest that the life-supporting earth has been in existence for almost as long as it is possible, over four thousand million years. That has given a very long time for life to evolve, so we might be the most advanced life form.

Silicon is similar to carbon in its valency. Science fiction writers have suggested that it could be the basis for different silicon-based forms of life elsewhere in one of the universes. Life could exist where temperatures make carbon life impossible. 'It's life Jim but not as we know it.' Notice that silicon is beneath carbon in the table and under that is germanium. Germanium was unknown to Mendeleev but from his table he predicted it and its properties, calling it ekasilicon. He proved correct, adding strength to the idea of the table. Because of its quad valency germanium got transistors started but silicon is now the basis for all electronic chips. A pub quiz bit of information is that at first the only source of germanium was the soot in chimney flues. For the benefit of non-Brits a pub quiz is run by a landlord to sell more beer. Teams compete to get the most correct answers, a modest cash prize and intense hatred. Quizzes are a national obsession. Some think that carbon in the form of graphene might be used for chips as well. Graphene is a single layer of carbon atoms and is already used in some of the batteries we use to fly.

## Solvents

Some liquids, called solvents, can break molecules apart. Examples are water, alcohol and propanone (acetone). When broken apart — dissolved — in water, table salt (sodium chloride) splits into a positive

sodium ion and a negative chlorine ion. In effect the solvent breaks the electron exchange link but the electrons remain with the atom they have been shared with. The ions are free to move around in the salty water so if a battery is connected an electric current flows. Salt water therefore conducts and such a liquid is called an electrolyte. When the ions reach one of the plates (electrodes) they either gain or lose electrons and become a neutral atom again, as shown in Picture 13. The sodium on one plate reacts with the water and produces hydrogen gas and the chlorine on the other plate bubbles off. Doing this to sea water using solar cell electricity is one clean way to generate hydrogen for such as house heating, car engines or aircraft turbines.

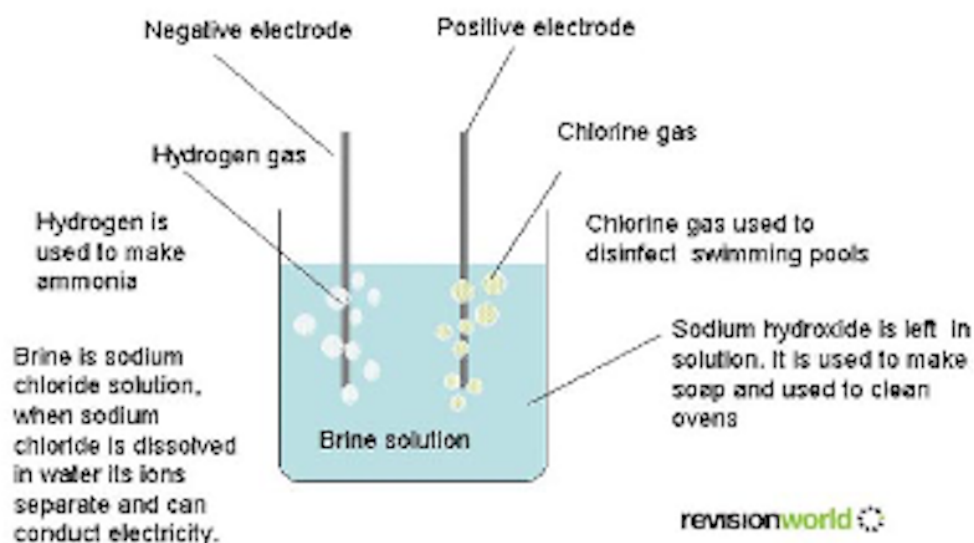

Picture 13 (credit: Revision World)

The ability of a metal to take part in chemical reactions depends, in part, on the ability of the metal to lose electrons to form a metal ion. Very reactive metals lose electrons easily. Very unreactive metals do not.

When two metals are placed together, electrons tend to leave the more reactive metal and travel to the less reactive metal. A cell is a particular way of allowing electron transfer between metals so that an electric current is produced.

We can use this effect for electroplating. Imagine a solution of metal ions, for example zinc or gold. We dip two plates of cheaper metals, such as steel or copper, into the liquid and connect to battery. The metallic ions will pick up one or more electrons and become a metal again. One of the plates will become covered in a very thin layer of the metal in solution. In the case of zinc this is galvanisation. More important for us, gold plating the connectors in our electronic equipment ensures that connection will not be lost due to corrosion. Gold is very unreactive so does not rust away nor tarnish.

## Careful How You Ditch

When in 2016 the Solar Impulse electric plane flew around the world the pilots were told what to do in the event of ditching in the sea. They must jump out well before the plane was likely to hit the sea. There is a large quantity of high voltage electricity in the cells, and the salty sea water is conductive enough to electrocute the pilot. There will be similar concerns when more aircraft go aloft powered by huge batteries. Fresh water is safer having many fewer ions in it, though it was said at one time that some of the rivers in industrial Europe were so polluted that you could develop photographic film in them. Being dissolved in water, and no doubt other liquids, the impurities would be in ionic form. If you ditch an electric model in water it might be worth checking around for dead fish to barbecue over the burning wreckage of your model.

## Experiment Two

Buy some pure copper and zinc sheets or foil about 1 to 1.5 mm thick. You won't need much and can find it on ebay quite cheaply. Alternatively you could use galvanised washers and copper coins. Note that many coins that look like copper are actually coloured steel. Clean the surface of the metals using alcohol, steel wool or sandpaper, then cut some 25 mm squares. Find some felt fabric a couple of mm thick and cut squares a little smaller than the metal.

The felt must hold water so a natural fibre like wool is best. Mix up a saturated salt water solution using cold water. Add salt until no more will dissolve but this time there is no need to filter it.

In Picture 14 are the 25 mm squares of zinc, copper and felt and the tin snips that I used to cut them from the sheets. I then flattened them with a hammer and cleaned the surfaces.



Picture 14 (credit: Peter Scott)

You will also need a voltmeter and ideally a bare light emitting diode (LED) available cheaply on ebay or ask the club's electronics guru for one. (Picture 15)

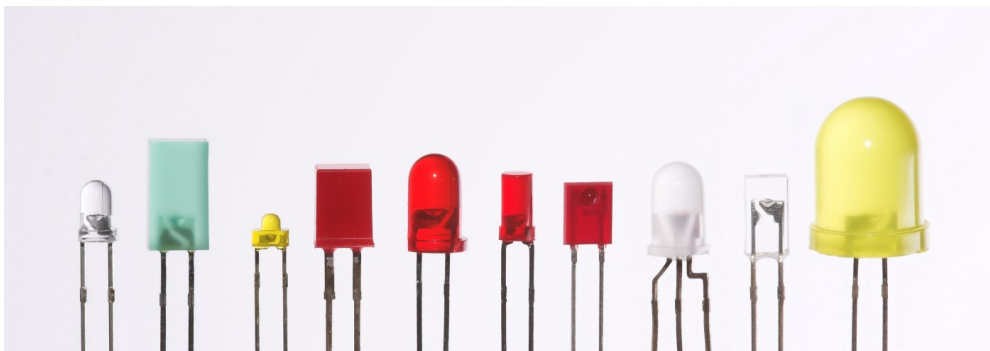

Picture 15: LEDs come in an almost infinite variety of shapes, colours and sizes. (credit: Afrank99 / Wikimedia under Creative Commons Attribution-Share Alike)

2.0 Generic)

LED – any colour will do, though red needs the least voltage

Soak the cloth pieces in salt water, squeezing and dunking to ensure they are well saturated. Put a copper square down and put a felt square on top. Put a zinc square on top of that. Touch the voltmeter probes, one on each metal, with the red on the copper. Press down gently on the zinc to ensure good contact. You could see a voltage of about 0.7 V but possibly a bit lower.

Now stack up four layers as follows: copper, cloth, zinc, copper, cloth, zinc and so on. End with with zinc as shown in Picture 16. Again test with the meter. Try connecting the LED and see if it lights. Connect the longer leg of the LED to the copper and the shorter to the zinc. Don't worry. If an LED fails it won't blow up in your hand. You can always remove one of the pairs of copper and zinc to reduce the voltage.

If nothing happens it might be because salty water is running down the sides of the pile and shorting the voltages. Pick the stack up in one piece, dry the sides and try again.

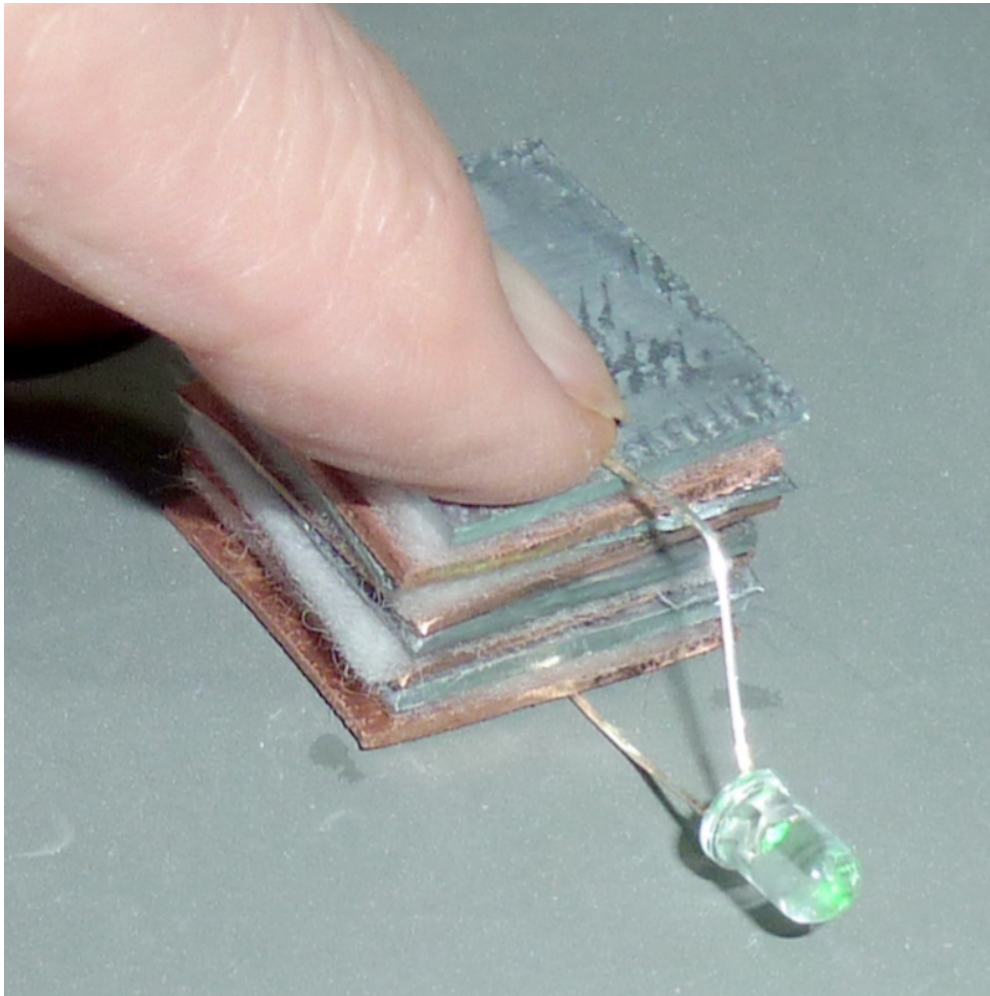

Picture 16 (credit: Peter Scott)

The green LED is glowing with a pile of four sets of copper/felt/zinc. What is the photon and quantum jump size? Yes, you got that right, 3.5 eV.

You have just made a Voltaic Pile (Picture 17), which was first invented in 1800 by Alessandro Volta after whom the volt, the unit of electric potential is named. Seats in Italy were often made of cold marble. (Pile. Geddit?) Each copper/felt/zinc layer is a cell and the whole pile is a battery. The cells are in series so the voltages just add up. For a long time batteries were the only way to generate electric currents in research laboratories. The Royal Institution labs in London were successful partly because of their large battery room. The metals are called plates or electrodes, with the positive copper one called an anode and the negative zinc one a cathode.

**Alessandro Volta (1745–1827)**



Volta was born in Como, a lakeside town in northern Italy. His greatest achievement was showing that electricity could be made from chemical cells. To be fair it was Luigi Galvani who, by making salt pickled frog's legs jump on a stand made of iron and copper, first showed that different metals could produce a voltage. That inspired Mary Shelley's book *Frankenstein; or, the Modern Prometheus* in 1818 with electricity bringing the creature to life. Galvani also suggested the reactivity series. However Volta's batteries led to large amounts of electricity being available in laboratories enabling the work of Faraday, Oersted and many others. The Royal Institution in London, to which he sent his experimental reports, was an early leader in this field. He also studied methane and the electrical property we now call capacitance and showed that voltage is proportional to charge in a capacitor.

His work on cells was admired by Napoleon Bonaparte, who, when he wasn't ravaging Europe in his appalling manner, was a great innovator, with his Code Napoleon legal system, a modern, secular education system and of course the metric system for weights and measures in 1799. Yes it has been around that long. Volta maintained a friendship with Boney and received many awards from him including the Légion d'Honneur. He spent his working life at Pavia University in Italy and was respected by his students even though he was a private man. The SI unit of electric potential, the volt, is named after him.

When you take your pile apart you will see from the surfaces of the metals that there have clearly been reactions. The zinc is much more affected than the copper. It is more reactive which is why it becomes more negative than the copper and so forms the cell voltage. More about that later.

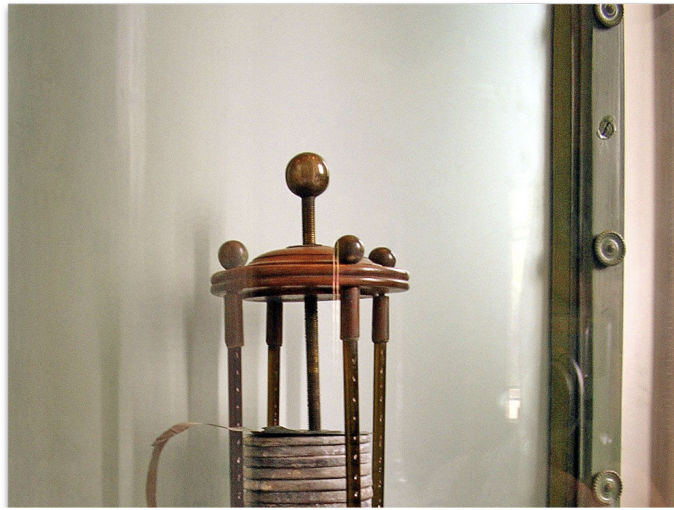

Picture 17 (left): Volta's original pile. (credit: GuidoB under Creative Commons Attribution-Share Alike 3.0 Unported) | Picture 18 (right): What voltage would you expect from the pile in Picture 18? Yes, about 6 V.

## Experiment Three

You will now need a lemon and a raw spud (potato). Push a copper and zinc square or a copper coin and a galvanised washer into the lemon a centimetre or so apart, as shown in Picture 19. Test the voltage. The acidic juice reacts with the metals to create the voltage. The same will work with a potato which will give about 0.8 V. So if you have an electric car and you run out of charge on the way home from the supermarket all you need to do is open up the sack of potatoes you just bought and hook them all up in series. Or maybe not.

Picture 19 (credit: Peter Scott)

You might have some crocodile clip leads for your voltmeter. If so try clipping them onto the zinc and copper electrodes and dipping them into other liquids. If you have some citric acid crystals in your kitchen try a saturated solution of that in water (0.85 V). Also try vinegar (0.91 V). The bracketted voltages are what I got. Both are fairly strong acids that increase the reactivity of the metals. Best avoid someone's glass of wine as it will change the flavour for the worse and dissolved copper is a poison. Don't try strong acids nor other liquids unless you are a chemist and know what you are doing.

## Primary Cells

All of the above cells are primary cells, meaning that the materials involved get used up and the cell cannot be recharged. Rechargeables are called secondary cells and will be described later.

The zinc-copper cell only produces only about one volt. But, as we know, some cells produce much more. A dry cell (C or D) makes 1.5, a nickel metal hydride (NiMH) cell is about 1.2 and a lithium polymer

one (lipo) can reach 4.2 V. Why is that? To answer that we have to look into reactivity which will be later.

The salty felt is called an electrolyte. Yes, it's the same word used for what you might need to top up when you are sweating a lot. Ions like sodium and potassium are essential in your body fluids to enable its many reactions and they are lost through sweating. Pet animals will lick you to get salt from your skin and large animals like cattle are given salt licks. It is one time when replacing salts is important, rather than just drinking pure water. So remember that on a long, hot day on the flying site, especially if you had to climb to get there. You can buy soluble tablets with a pleasant flavour from cycling or athletics shops. Low electrolytes can lead to tiredness, muscle cramps, confusion and dizziness.

## **Rechargeable or Secondary Cells**

To be rechargeable a cell or battery must be made of materials whose chemical reactions are reversible. We add energy to the battery using a reverse current and we see this energy as a raised voltage. In different types of battery the materials change in a number of different ways. The surface of the anode and cathode, or the molecules in the electrolyte, might change, or both. The chemistry is complicated and beyond us here.

When we finish charging and connect our motor or lamp the energy returns from the electrolyte or plates as a current in the connected conducting metals.

## **Reactivity**

At the beginning of this article I mentioned that some elements lose electrons more easily. This enables them to produce higher cell voltages and to join on to other elements to form compounds. If two metals are placed together electrons leave the more reactive metal and join the less reactive metal. So to work out what pairs of

elements will make the best cells we need a list putting reactivity on order from most to least. In a cell the two elements are connected by an electrolyte. This might be liquid or paste.

This is not the full list of elements. I have just included the elements that are of interest to us in the cells we use. To find what cell voltage we can expect when using these elements we combine the potentials shown in Figure 2. Zinc (Zn) has -0.76 and copper (Cu) has +0.34. Combined these make 1.1 V which is not far from what we found in our experiments.

Figure 2: Standard reduction potentials in volts.

What can we learn from this table?

Lithium is the obvious preferred choice with its large potential. Sodium is not far behind and is a sound second, or perhaps first choice, as you will learn if you read my article on cell technology. It is also cheap and plentiful. Aluminium looks promising too. You can see why the old nickel iron (NiFe) cells were low voltage ( $0.25 + 0.77$ ). NiMH cells are not included because the second plate is not an element but a compound hydride. What voltage should you get if you replace the zinc with aluminium? If you try it using the method in experiments 2 and 3, sand the surface of the aluminium just before you use it as it soon combines with oxygen to form a grey insulating layer. Because of course it is reactive.

Next month, I'll turn my attention to forces and inertia. Thanks for reading!

©2022

## Resources

- [Peter Scott](#) – The contact page on the author’s personal website.
- [How to Grow Great Crystals](#) – From the *Instructables Workshop* website: “After a little research on Instructables.com, I didn’t find an instructable which show you how to grow big and beautiful crystals. So I think that this instructable is a good idea...”
- [Band Theory of Solids](#) – From the *OpenStax* website: “The free electron model explains many important properties of conductors but is weak in at least two areas. First, it assumes a constant potential energy within the solid...”
- [Band Theory of Solids](#) – Slidedeck from the *LearnPick* website.
- [The Reactivity \(Electrochemical\) Series](#) – From the *Richard Bowles* website: “A salt is a chemical containing a metal ion and a negative ion bonded together. The metal ions might consist of copper, sodium or zinc etc...”
- [Band Theory of Solids Solid-State Device Theory](#) – “Quantum physics describes the states of electrons in an atom according to the four-fold scheme of quantum numbers...”
- [Astronomers Reimagine the Making of the Planets](#) – From *Quanta* magazine: “Observations of faraway planets have forced a near-total rewrite of the story of how our solar system came to be...”

## Also by the Author

- [Electricity for Model Flyers](#) – The author’s complete, highly regarded series presented on the pages of the *New RC Soaring Digest*.
- [Cellmeter 8](#) – “What’s on offer for this economical battery meter and servo tester? Quite a bit, actually...”
- [The Fine Art of Planking](#) – “The time-tested method for moulding strips of wood into an organic, monocoque structure...”

Read the [next article](#) in this issue, return to the [previous article](#) in this issue or go to the [table of contents](#). A PDF version of this article, or the entire issue, is available [upon request](#).

## Soaring the Sky Podcast



### E122: Amelia The Glider Pilot

*Our sixth instalment of this ongoing series where we select and present episodes from Chuck Fulton's highly regarded soaring podcast. See Resources, below, for links where you can find Soaring the Sky, or simply click the green play button below to start listening.*  
– Ed.

On this episode Chuck talks with Amelia, a glider pilot soaring in the United Kingdom. Yes her name fits her very well as you will soon find out. At just 15 years old she is already making an impact on the sport. She loves sharing her soaring journey on Instagram (see *Resources*) and already has over 60,000 followers! Ameila also recently was ask to be the roving reporter for the buildup to the 2022 Womans' Worlds and she has already interviewed several pilots that will be in that event this year there in the UK in August. As you will hear today Amelia is always so excited to share with the World this amazing sport and has lots of soaring stories she shares with us today.



Later on this episode our good friend Sergio The Soaring Master is back with another very informative segment and this one is about discarding thermals.

©2022

## Resources

- [@amelia\\_glider\\_pilot](#) – Amelia’s account on Instagram, now with 83,600+ followers!
- [Soaring the Sky](#) – From the website: “an aviation podcast all about the adventures of flying sailplanes. Join host Chuck Fulton as he talks with other aviators around the globe”. You can also find Chuck’s podcast on [Instagram](#), [Facebook](#) and [Twitter](#)

Subscribe to the *Soaring the Sky* podcast on these preferred distribution services:

## Bespoke Battery Packs

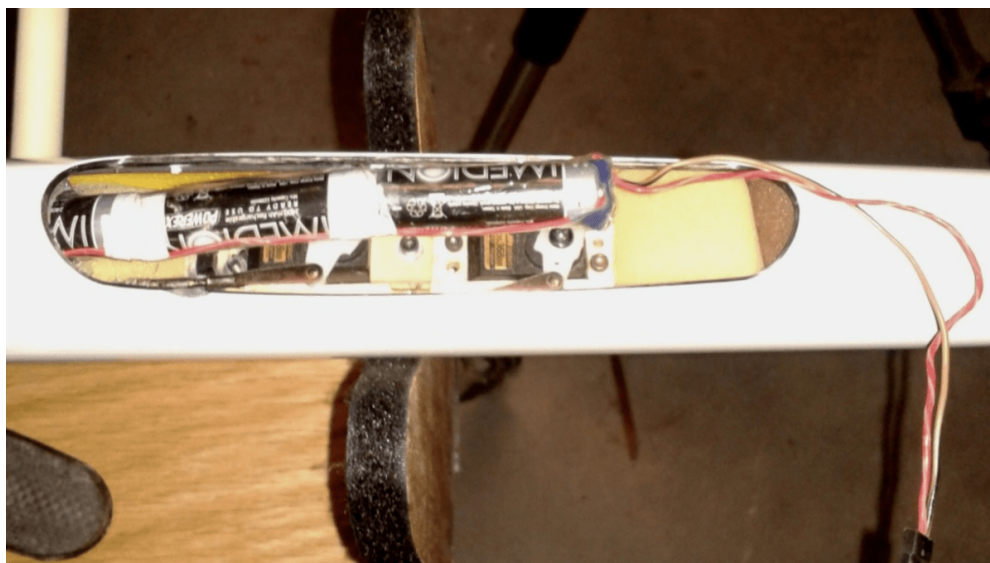

### Your battery doesn't fit in that broomstick? Build one that does!

The first pack is fairly self-explanatory. Separate the pack into two, two-cell units. This makes it easier to fit into narrow fuses and saves having to take servo trays out:

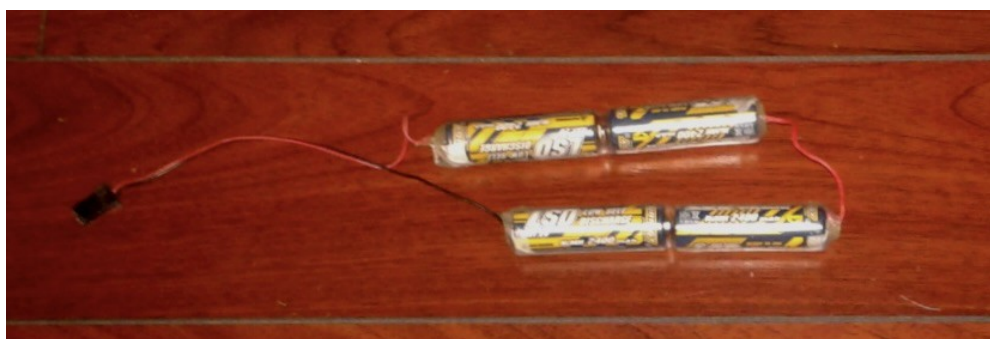

The second is a ballast tube battery. It can sometimes fit under the ballast tube. I use it in my *AVA* tube and under my *Royale XC* tube. Comes in handy for those very long flights for XC or for the LSF eight hour task. It is made up of two, four-cell packs in parallel. Two 2400mAh four-cell packs make a 4800mAh double pack:

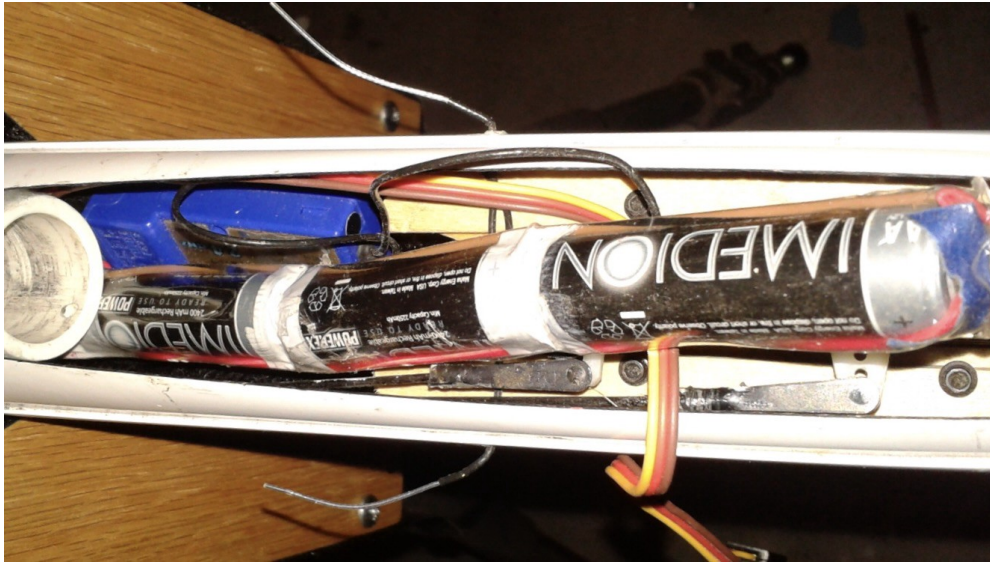

## Step 1

Solder together two, four-cell units. I use *Soder-Wick* fine braid (see *Resources*), since it solders well and bends easily:

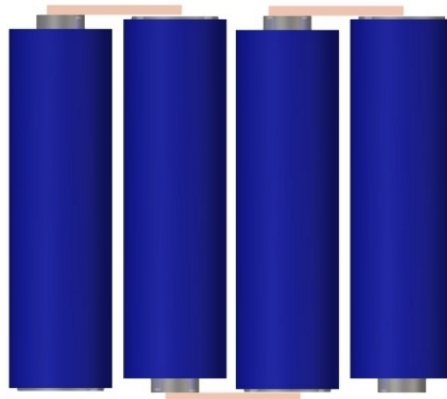



## Step 2

Lay the pack out straight. I usually put a piece of tape around each joint to keep it together:



## Step 3

Solder the two, four-cell packs together in parallel. Positive-to-positive in the middle. You can do negative-to-negative also if you wish. Attach a good length of appropriately colored wire also:

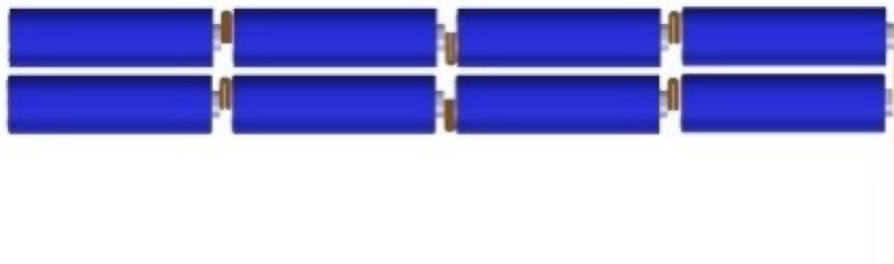

## Step 4

Lay this out straight and solder the negative wire to the bottom and top of the pack. You now have two, four-cell packs in parallel. I shrink tube the pack, but it will work fine with just taping it together:



You could also use a single, four-cell tube pack, if they are the same type and amperage battery, and connect to your receiver along with your normal nose pack. I have the same type four-cell pack in the nose of my *Royale XC* and with the three in parallel, I actually have 7200mAh to run on.

Until next time!

## Stamps That Tell a Story



### Wave soaring and the altitude records of Bill Ivans set in 1950 over Bishop, California.

The San Marino Post Office issued a set of three stamps in honour of the fiftieth anniversary of gliding and soaring in Italy showing a Caproni-Vizzola *Calif* A-21 sailplane superimposed on different stylised air currents. The postage stamp shown below could indicate the ‘laminar’ air flow of the atmospheric wave currents. This A-21/A-21J sailplane, according to the manufacturer, was to be the “dream ship that came true,” it is spacious and curvaceous, and was produced in both, unpowered and jet-powered versions.

Sweden Post issued a set of four coil stamps showing different cloud formations, seen over their country during the year. A typical wave cloud, as it is seen in many parts of the world, is shown on the 5.20 krona value we have featured.

Although much of the wave flying in Sweden is done by taking off from frozen lakes during the winter, glider pilots take advantage of this cloud formation from October through March and early April. The

current Scandinavian altitude record was set by Per Fornander flying a standard *Jantar* on March 19, 1986, with a total altitude of 10,200m (33,466ft) and an altitude gained of 9,600m (31,497ft).

The souvenir sheet of poster stamps shows six different designs printed in four colours. It is not known how many sheets were printed and how many were sold, but they are not very common today. The British Gliding Association, full of ideas as usual, produced a set of gliding stamps with the aim of increasing public knowledge and enthusiasm for our movement. It was hoped that readers of their magazine (*Sailplane & Gliding*) would realise that if sufficient interest was created with people collecting the full set of postage stamps it would help the sport and promote gliding internationally. Accordingly it was suggested that everyone should buy a set and attach them to their Christmas letters. It was hoped that once the craze started there would be a snowball effect.

One of these vignettes, shown above at the top right, features the Schweizer SGS 1-23 in which William S. Ivans flew two world records on December 30, 1950. The altitude gained above release was 9,174m (30,100ft) and the absolute altitude was 12,831m (42,100ft).

This flight was above the Owens Valley, near Bishop, California, USA, in strong wave updrafts formed in the lee of the Sierra Nevada mountain range. Bill and his all metal 1-23 is also shown on the cover of a 1953 *Flying* magazine (see below left).





The historical development of utilising the meteorological phenomena by glider pilots was discussed in detail by Wolf Hirth in his booklet *Mit dem Segelflugzeug in die Stratosphäre*. (Above right.) He writes that these still not understood air currents can only be explained by soaring pilots

Much of the early scientific wave exploration was in the early 1950s in the Sierra Wave in California. On June 15, the National Soaring Museum (Harris Hill, Elmira, New York) are dedicating its 12th National Landmark of Soaring at Bishop, California (see also Bertha M. Ryan's *The Gathering of Eagles*.)

A bronze plaque [was] erected at the Bishop Airport to honour the contribution to the sport of soaring by participants of the Sierra Wave Project. Several of the original participants [were] at this historic event.

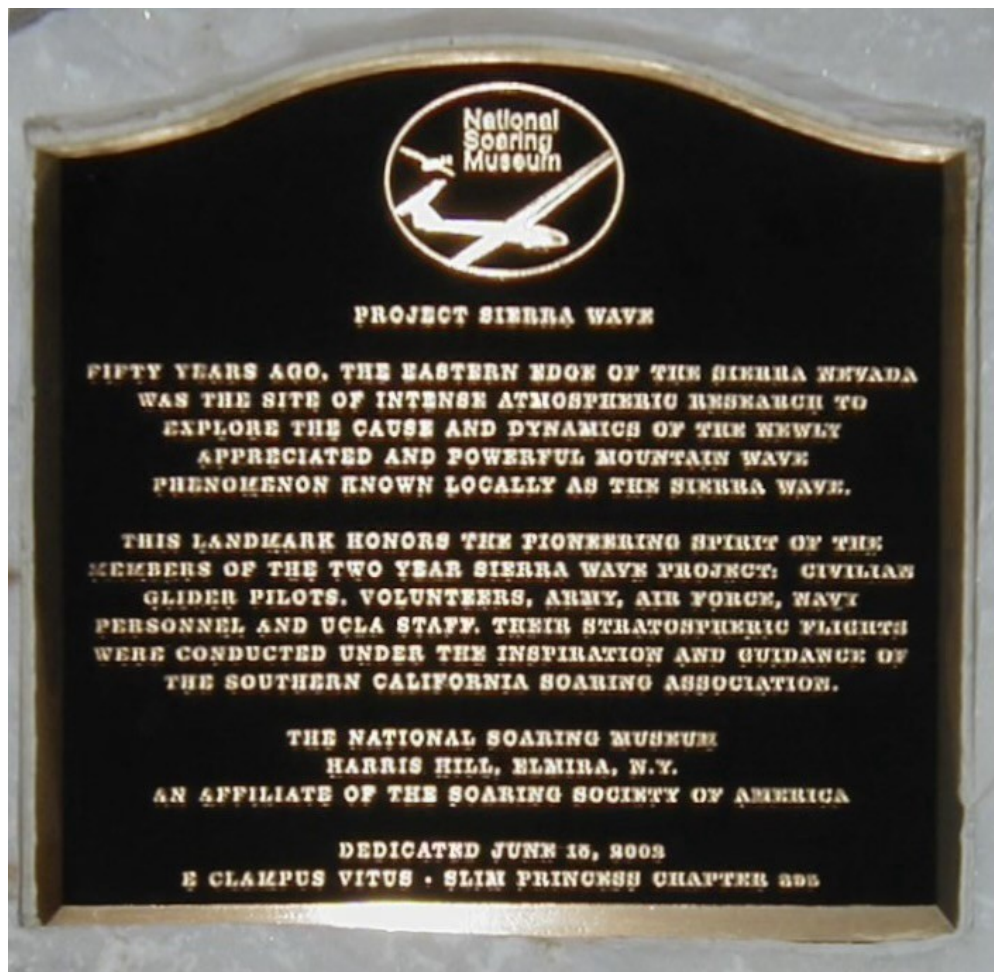

Although this image did not accompany the original version of this article, it's a worthy addition to the record. (credit: Simine Short)

## Resources

*Note: we have provided Ms. Short's original references, only one of which we were able to provide find a current link. But perhaps your search skills are better than ours and you can track these related works. – Ed.*

- Bertha M. Ryan's ***The Gathering of Eagles*** originally publishing in *Gliding* magazine.
- Algotson, Rolf and Yngve Norrvi (1984). ***Segelflyg i Lävågor*** Published by the Kungl. Svenska Aeroklubben, the Svenska Flysportförbundet and the Segelflygskolan Ålleberg.
- Edgar, Larry. ***High Flight in a Mountain Lee Wave*** A first person account of a still standing (set in 1952) world altitude record in a two-seater (a beefed up war-surplus Pratt-Read) is published in the June 2002 issue of *Soaring*. Larry was one of the members of the Sierra Wave Project.
- Hirth, Wolf (1951). [\*Mit dem Segelflugzeug in die Stratosphäre\*](#) (4.2MB PDF) Verlag der Weltluftfahrt, Coburg. My thanks to Klaus Heyn and Peter Selinger, Germany, for pointing out and then supplying this booklet to me.

## Also by the Author

- [\*\*\*Stamps That Tell a Story: The Series\*\*\*](#) – Catch up on your missing instalments of this excellent and informative series of articles presented previously in the New RCSD.

*This article first appeared in the July, 2002 issue of Gliding magazine. Simine Short is an aviation researcher and historian. She has written more than 150 articles on the history of motorless flight and is published in several countries around the world as well as the United States. She is also the editor of the Bungee Cord, the quarterly publication of the Vintage Sailplane Association.*

Read the [next article](#) in this issue, return to the [previous article](#) in this issue or go to the [table of contents](#). A PDF version of this article, or the entire issue, is available [upon request](#).

## Glider Patents

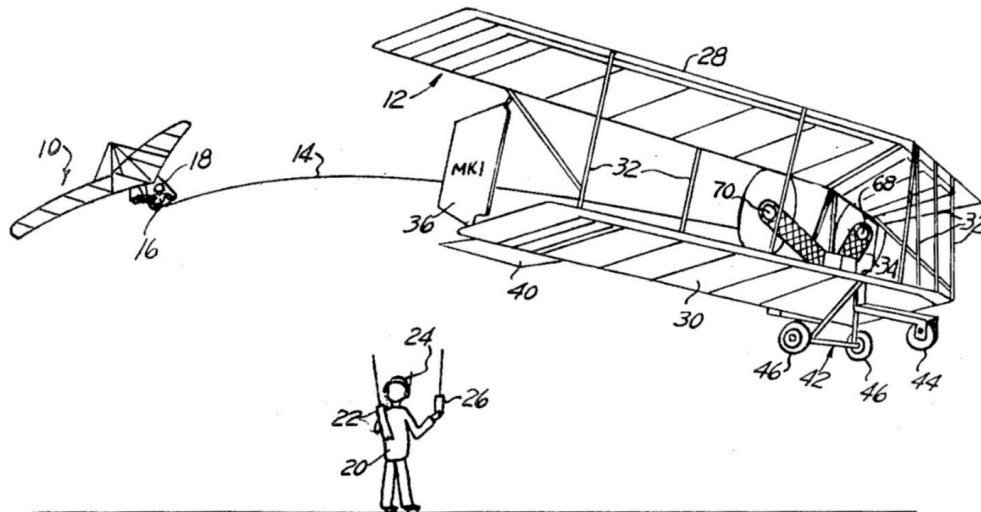

### US 4,248,394: Remote Control Hang Glider Towing Aircraft

*This is the fifth in our series of glider-related selections from the files of the US Patent and Trademark office (see Resources, below). They are presented purely for the interest and entertainment of our readers. They are not edited in any way, other than to intersperse the drawings throughout the text. Disclaimers: a) Inclusion of a given patent in this series does not constitute an expression of any opinion about the patent itself. b) This document has no legal standing whatsoever; for that, please refer to the original document on the USPTO website. – Ed.*

- [54] **REMOTE CONTROL HANG GLIDER  
TOWING AIRCRAFT**
- [76] Inventor: **Marlin K. Klumpp**, 1520 Avondale,  
Ann Arbor, Mich. 48103
- [21] Appl. No.: **17,411**
- [22] Filed: **Mar. 5, 1979**
- [51] Int. Cl.<sup>3</sup> ..... **B64D 3/00**
- [52] U.S. Cl. .... **244/3; 244/16;**  
**244/DIG. 1**
- [58] Field of Search ..... **244/3, 16, DIG. 1, 190;**  
**242/107**

[56] **References Cited**  
**U.S. PATENT DOCUMENTS**

D. 243,594	3/1977	Koch	.....	244/DIG. 1
2,969,934	1/1961	Gallagher et al.	.....	244/190
2,991,959	7/1961	Rizzo	.....	244/3
3,272,457	9/1966	MacMillan	.....	244/3 X
3,744,759	7/1973	Jennings	.....	242/107
3,817,472	6/1974	Abe	.....	242/107
3,957,230	5/1976	Boucher et al.	.....	244/190 X

**FOREIGN PATENT DOCUMENTS**

2752182 6/1978 Fed. Rep. of Germany .... 244/DIG. 1

**OTHER PUBLICATIONS**

Welch, "Hang-Gliding Review", *Flight International*,  
Dec. 1977, pp. 1741-1744.

"SO-LO Volmer VJ-11", *Hang Gliding*, by D.  
Poynter, 1976, p. 152.

*Primary Examiner*—Barry L. Kelmacher  
*Attorney, Agent, or Firm*—Hauke and Patalidis

## Abstract

A remotely controlled powered aircraft equipped with engine, propeller and landing gear, radio-controlled from the ground and capable of towing a manned hang glider to an appropriate altitude. On reaching altitude, the pilot of the hang glider releases the tow, and the pilotless towing aircraft is returned to the launching site under radio control from the ground. During towing of the hang glider, two-way communication is maintained between the hang glider pilot and the towing aircraft remote pilot.

## Background of the Invention

The present invention relates to hang gliding in general and more particularly to a method and to a combination of elements for launching aloft a piloted hang glider by means of an aerial tow consisting of a powered pilotless aircraft remotely controlled from the ground.

Hang gliding is generally considered to be the precursor of modern aviation. George Cayley in England in the middle of the nineteenth century, Otto Lilienthal in Germany and Percy Pilcher in England, at the end of the nineteenth century, practiced hang gliding. Wilbur and Orville Wright's first Flyer was a form of hang glider.

Hang gliding has recently become a very popular sport practiced by many enthusiastic flyers, as a result of the work of Francis M. Rogallo investigating for NASA the use of para-gliders as recovery devices for manned spacecraft. A Rogallo wing is a kite-like structure in the form of a low aspect-ratio delta wing with a simple frame covered by a lightweight material, Dacron or the like, below which is mounted a support harness for the pilot who, by pulling and pushing on a horizontal control bar or trapeze, which is attached by cables or rigid rods to the wing keel and by cables to the tips of the wing, controls the glider in flight by moving his body fore and aft to shift the center of gravity relative to the center of lift of the wing, and sideways for banking and thus turning.

Since the appearance of the Rogallo wing, many other types of hang gliders have been developed, successfully flown and manufactured. As a result, many designs and types of hang gliders can today be found on the market, of the monoplane as well as biplane type, of the tailless as well as of the tailed type, and some provided with directional control surfaces. Although the trend is towards gliders having higher aspect ratio wings, which in turn has resulted in improved glide ratios thus resulting in soaring of longer duration and greater distance, launching without assist remains the principal obstacle to full enjoyment of the sport of hang gliding, as long as launching remains the timehonored method of running upwind down a slope, in order to gain critical flying speed. As long as the angle of the slope or hillside is greater than the gliding angle, the hang glider lifts itself into the air when its air speed reaches approximately 15 to 20 mph, and is thus able to glide to the bottom of the slope or hill, the pilot taking advantages of any lift provided by thermals or any ascending air currents caused by the wind blowing up the slope or the hillside to prolong his flight. Such a method of launching requires appropriate launching sites with appropriate hilly or mountainous terrain, which are not always available in the near vicinity.

Several methods and devices can be used to launch manned hang gliders from the ground, in order to permit soaring flights

notwithstanding the absence of hills, dunes or mountains. Such launch assist methods or means include towing the hang glider behind a motor boat or a land motor vehicle, by means of a winch, or by means of a powered light aircraft. Hang gliders have also been launched at altitude from hot air balloons. Power assist for hang gliders such as small gasoline engine driving a conventional propeller, and even small low thrust jet engines have appeared on the market. Such power assists are attached to the hang glider and permit limited power flight to altitude, or cruising on power.

Towing a hang glider behind a motor boat or behind a land motor vehicle, and launching by means of a winch present many problems and limitations, the most important of which is a limit on the altitude which the hang glider can reach when launched by means of such assist. Launching from a hot air balloon is much less altitude limited but it is very expensive and requires special skills on the part of the hang glider pilot, as the launch is effected without air speed and consists in a vertical drop followed by a stall recovery. Providing a hang glider with an auxiliary power in the form of a small gasoline engine and propeller, or a jet engine, is also costly, and is considered by other flyers as a noisy and undesirable nuisance and somewhat of a heresy. When the engine is stopped, soaring, unassisted, becomes somewhat limited in view of the increase in gross weight due to the weight of the powerplant and the additional drag created by the propeller and the powerplant frontal area, and stalling and landing speeds are appreciably increased. As a result, power assisted hang gliders tend to evolve in the direction of uncertified light aircrafts, to the point that even landing gears for motorized hang gliders have now appeared on the market.

Although towing a high aspect ratio conventional glider or sail plane to altitude behind a light powered aircraft is a conventional method for rapidly launching a great number of gliders in succession, such method has very seldom been used for towing hang gliders, because of the many problems involved, the most important of which is the difference in speed ranges between a conventional hang glider and a

light aircraft. The maximum air speed of the majority of hang gliders is much less than the minimum flying speed or take-off speed of the majority of light aircrafts. In other words, a light aircraft towing a hang glider takes off at an air speed which is beyond the maximum, or “never exceed” air speed, to say nothing of the maximum maneuvering air speed, of the hang glider.

The present invention provides a powered towing aircraft which enables a hang glider to be towed to altitude and launched from such altitude over any kind of terrain, including flat ground. The towing aircraft of the invention provides an adequate thrust for take-off and climb to altitude with a hang glider in tow, has a low minimum air speed matching the hang glider minimum air speed, and a climb air speed and climb rate closely matching those of a conventional hang glider, is pilotless but highly controllable, does not place any excessive demand on the flying ability of the pilot of the towed hang glider, and provides at least a level of safety comparable to other means of launching a hang glider, such as by means of a winch, or by towing behind a land or a water vehicle.

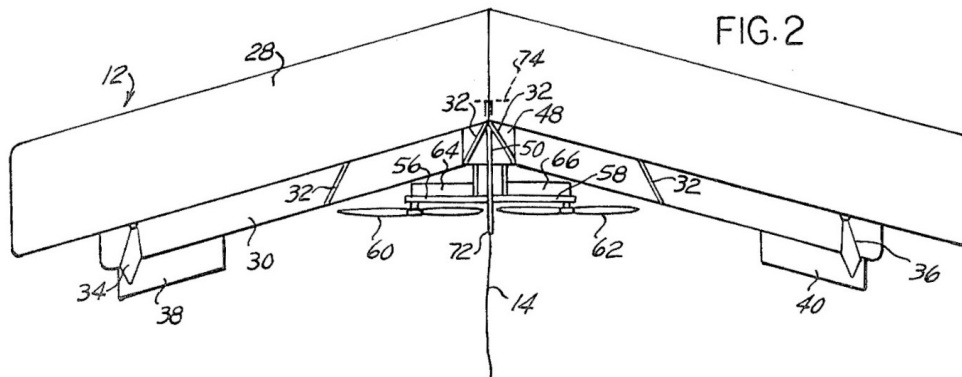

The minimum thrust required for enabling a hang glider with its pilot to maintain flight, with enough reserve power for a moderate rate of climb, in a standard density and temperature day is in the neighborhood of 80 lbs. The thrust applied to a towed hang glider by a towing aircraft must therefore be at least 80 lbs. and preferably have a value of around 100 lbs. Most conventional hang gliders have a practical air speed range of about 16–20 mph minimum to about 35–45 mph maximum. The towed climbing speed for hang glider is



therefore in the range of approximately 25 to 30 mph, and therefore the minimum air speed of a towing aircraft for a hang glider should not be greater than about 25 mph, and the towing aircraft must be fully controllable at such a low speed. A climbing speed, slightly above the take-off speed, must be maintained to altitude, under control, in order not to overstress the structure of the hang glider and its pilot's ability to cope with excessive demands upon his flying skill.

All those requirements are fulfilled by the present invention, and furthermore the present invention provides a reasonable amount of safety in view of the fact that the towing aircraft is pilotless and that disconnect between the towing aircraft and the towed hang glider is under the control of the hang glider pilot who can always safely disconnect and make a relatively normal landing irrespective of what may happen to the towing aircraft.

## **Summary of the Present Invention**

The present invention accomplishes its purposes by providing a towing aircraft, remotely controlled from the ground, whose specifications closely match those of a towed hang glider, and which is capable of towing the hang glider and its pilot to an appropriate launching altitude, the towing aircraft remote pilot, on the ground, constantly remaining in radio communication with the hang glider pilot. The many objects and advantages of the present invention will become apparent to those skilled in the art when the following description of the best modes contemplated for practicing the invention is read in conjunction with the accompanying drawing wherein:

## **Brief Description of the Drawing**

FIG. 1 is a schematic perspective view of an example of a remote control powered aircraft towing a piloted hang glider to altitude while being remotely controlled from the ground, according to the present invention;

FIG. 2 is a plan elevation view, from the top, of the towing aircraft of FIG. 1;

FIG. 3 is a rear elevation view thereof;

FIG. 4 is a schematic block diagram of the remote radio control thereof;

FIG. 5 is a schematic elevation view with a portion removed of the two line wind-up mechanism thereof; and

FIG. 6 is a partial perspective view, with portion removed to show the internal construction, of an example of hang glider tow line hitch, according to the present invention.

## Detailed Description of the Preferred Embodiment

Referring now to the drawing, and more particularly to FIG. 1 thereof, a conventional hang glider **10** is illustrated under tow by a remote radio control powered aircraft **12**, through a towline **14**. The tractor aircraft **12** is pilotless but the hang glider **10**, provided in a conventional manner with an appropriate pilot supporting harness mounted under its wing, carries a pilot **16** who controls the flight of the hang glider by means of a control bar **18**. The hang glider pilot **16** is in radio voice-communication with the crew member **20** on the ground, such as to be at all time able to give instructions to and receive instructions from the ground crew member **20**. For the purpose of two-way radio communication, the hang glider **10** is equipped with a low power radio receiver-transmitter, of the type currently referred to as "walkie-talkies", operating at any appropriate frequency, such as the 27 megacycle "citizen band" frequency or any other higher frequency. The radio receiver-transmitter may be carried by the hang glider pilot **16** in a pocket of his clothing apparel, or attached to his crash helmet or, in the alternative, attached to the hang glider superstructure such as the control bar structure. The audio output of the receiver is

provided through an earphone embedded in the ear covering portion of the crash helmet interior lining, and the microphone is preferably a conventional miniature microphone as available on the market in the form of a headset comprising earphone and a microphone in a single assembly commonly used by aircraft pilots, air traffic controllers and telephone operators. The microphone relay may be voice-operated or, in the alternative, operated by a "press to talk" button switch attached to the glider control bar. In a similar manner, the ground crew member **20** carries a radio receiver-transmitter **22** connected to an earphone-microphone headset **24**, to free his hands for operating a radio control transmitter **26**.

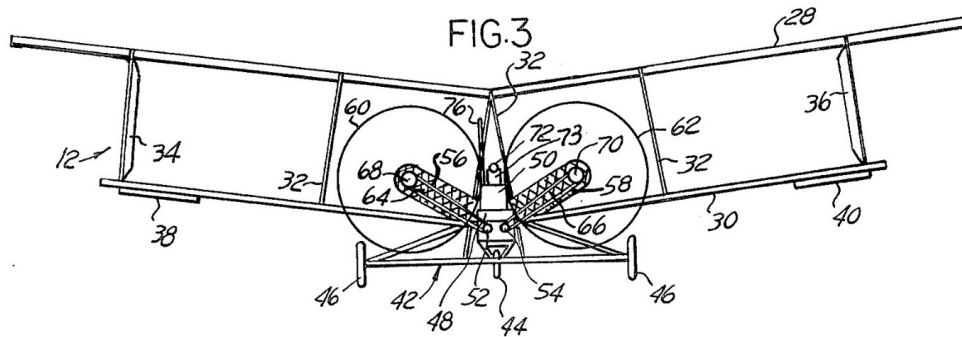

The example of tractor aircraft **12**, illustrated at FIGS. **1-3** is of the tailless biplane type sold under the trademark "EASY RISER" by the Ultra-Light Flying Machine Co., for convenience and illustrative purpose, although it will be appreciated that the tractor aircraft may be in the form of any one of the hang gliders presently available on the market which are capable of easy conversion to a power glider by addition of an appropriate small internal combustion engine and propeller unit, also readily available on the market.

The example of tractor aircraft **12** illustrated has a pair of swept-back rectangular wings, the upper wing **28** having a slightly wider span, of approximately 30 feet, than the lower wing **30**. Appropriate strut members **32** interconnect the upper wing **28** and the lower wing **30**. Proximate each wing tip, and disposed between the two wings, there is a substantially vertically disposed control surface, or "dragger", **34** and **36** respectively, which is controllably operable for pivoting about a vertical axis from a position aligned with the axis of flight to a

position at an angle thereto providing, by differentially operating either the left "dragger" **34** or the right "dragger" **36**, a turn to the left, or a turn to the right as a result of increased induced drag applied to the left wing tip or to the right wing tip. Because of the high dihedral of the wings **28** and **38**, any turn results in an appropriate banked turn without the aid of ailerons for rolling into the turn. The structure formed by the wings **28** and **30**, including the struts **32**, is a generally rigid structure which, when operated as a piloted hang glider, has a minimum flying speed and a maximum flying speed matching the minimum and maximum flying speeds other types of hang gliders, such as the hang glider **10**. When operated as a piloted hang glider, yaw control is effected by the pilot by means of appropriate separate control cables connected to the control horn of either dragger **34** or dragger **36**, which causes selective deflection of the appropriate dragger for turning in the desired direction. Turns are thus effected by the pilot without lateral shift of his body's center of gravity. For pitch control, the pilot shifts his body's center of gravity forward and aft in the conventional manner, in hang gliding.

For the purpose of the invention, a pair of elevator surfaces, **38** and **40**, are additionally mounted at the trailing edge of one of the wings, for example the lower wings **30**, proximate each wing tip. The elevators **38-40** are hingedly connected at their leading edge to the trailing edge of the wing, and are arranged for simultaneous operation in unison through conventional horns and control cables, not shown.

A tricycle landing carriage **42** is mounted below the lower wing **30**. The landing carriage **42** has a nose wheel **44** which is preferably of the trailing arm free-castering type to facilitate automatic alignment of the aircraft **12** into a head wind at take-off, or after touchdown at landing. For the sake of simplicity, the main wheels **46** of the tricycle undercarriage **42** are not provided with brakes, and the nose wheel **44** is not controllably steerable. This arrangement generally presents no problem but would generally require that the tractor aircraft **12** be hand-towed for taxiing to its take-off position, and again hand-towed after landing. However, for complete remote control of the tractor

aircraft **12** while taxiing, during take-off and during roll-out after landing, the nose wheel **44** may be provided with a steering servo, at the cost of one additional channel in the remote radio control system. Alternatively, the main wheels **46** may be provided with servo-actuated differential brakes, at the cost of two additional channels in the radio control link or, alternatively and preferably, at the cost of the brakes and servos alone, operated through the same two channels which operate the servos of the draggers **34** and **36** as will be hereinafter explained.

A housing **48** is mounted on the top of the lower wing **30** at its center. Preferably, the housing **48** has appropriate mounting means, resilient to a certain degree such as internal combustion engine mounts, directly supported by and fastened to the landing gear undercarriage **42** as well as being attached to the main spar or other framework of the lower wing. A portion of the housing **48** supports a light internal combustion engine **50**, preferably air-cooled which, alternatively, may be mounted directly, through appropriate shock absorbing means, to the wing spar and attachment points of the landing gear **42**. The engine **50** drives through an appropriate gear reduction drive or pulley and belt reduction drive a pair of output pulleys **52** and **54**, projecting rearwardly from the rear portion of the housing **48**. By means of reverse belting in the drive ratio reduction system, or by means of a reverse gear, one of the two drive pulleys **52** and **54** rotates in a reverse direction relative to the other. By means of belts **56** and **58**, respectively, the drive pulleys **52** and **54**, respectively, drive contra-rotating pusher propellers **60** and **62**. Through the use of contra-rotating propellers, or propellers rotating in opposite direction, the resultant torque applied to the aircraft **12** cancel each other, thus greatly simplifying yaw and roll control. The forward thrust of the propellers **60** and **62** is transmitted to the housing **48** through each one of a pair of inclined thrust and support members **64** and **66**, each made of a relatively light but relatively rigid metallic beam fastened at an angle at its base to a side of the housing **48**. Each thrust beam is provided at its free end with an appropriate journal and thrust bearing rotatably supporting a propeller shaft on which is keyed an

appropriate drive pulley, **68** and **70**, for the corresponding propeller, **60** and **62**, each propeller drive pulley being driven respectively by the drive belt **56** or **58**.

A towline hitch and guide mechanism is provided in the form, for example, of a tubular member **72** pivotably mounted, FIGS. **2** and **3**, at one end by appropriate brackets **73** to the housing **48** for free pivoting about a horizontal axis, as shown at **74**. The tubular member **72** thus is free to pivot to a certain degree about a horizontal axis between the two propeller discs but is restrained from lateral motion, or pivoting about a vertical axis, to prevent contact with the propeller tips. The tubular member **72** functions as a support and guiding means for the towline **14** during towing for preventing contact with the propeller tips, and during winding of the towline prior to landing, as will be hereinafter explained, by means of a winch mounted in or on the housing **48**. In arrangement and in locations where possible entanglement of a dragging towline with ground obstacles is not to be expected, the towline may simply be attached to a loop provided on the end of the tubular guiding and support member **72** or of a vertically pivotable rigid rod projecting between the two propeller discs.

The towline **14** is preferably a thin, relatively light cable made of synthetic material such as nylon and the like. A towline made of such material presents the double advantage of having a pronounced amount of elasticity under tension and, by proper choice of the line, of having a limited resistance to rupture under tension, such that the line will break prior to exerting a pull on the towed glider which could exceed safe limits. As about 100 lbs. thrust is adequate for towing the hang glider, an appropriate choice of line modulus of rupture under tension is limited to a maximum of about 300 lbs. for safety reasons. About 150 lbs. is the minimum which could be used to insure reliability of towing under normal conditions.

A radio receiver, not shown, and appropriate actuating servos are enclosed in the housing **48**, a vertically disposed whip antenna **76**

being mounted on the top of the housing **48** or at any appropriate other convenient location for receiving the signals emitted by the antenna of the radio control transmitter **26** at the disposal of the ground crew member **20**, FIG. 1. Vertically disposed whip antennas cause vertical polarization of the transmitted waves requiring a vertical aerial for receiving but, if it is desired to operate the radio control system with horizontal polarization in order to avoid interference with radio communications occurring on the same or on adjoining frequencies with vertical wave polarization, the antenna of the transmitter **26** may be disposed horizontally, and the whip antenna **76** of the receiver on the aircraft **12** may be replaced by a dipole antenna wire stretched above the upper wing **28** or between the two wings. The wing span of the towing aircraft **12**, being approximately **30** feet, provides ample room for spanwise mounting of a full wavelength dipole receiving aerial, even when operating in the convenient 27 Mhz frequency range.

The radio control system for controlling from the ground the flight of the tractor aircraft **12** consists of a multi-channel system quite similar to systems presently used for radio control of large model airplanes. As shown at FIG. 4, a 6-channel radio control system of the type currently available on the market at a relatively low cost is quite adequate for the present invention. A minimum of four channels are required, one of the channels being used for a throttle input **80**, and two channels for the yaw inputs, respectively the right yaw input **82** and the left yaw input **84**. Two yaw inputs are required for controlling the towing aircraft **12** in view of the fact that it is designed for separate actuation of the wing tip draggers for turning. By using a tractor aircraft in the form of a motorized hang glider provided with a conventional tail rudder, only one channel will be required for yaw input. The pitch control input and the towline winch drive-input, if used, require two additional channels. With the exception of the towline winch control input which is of the on-off type, all the other control inputs are of the proportional type.

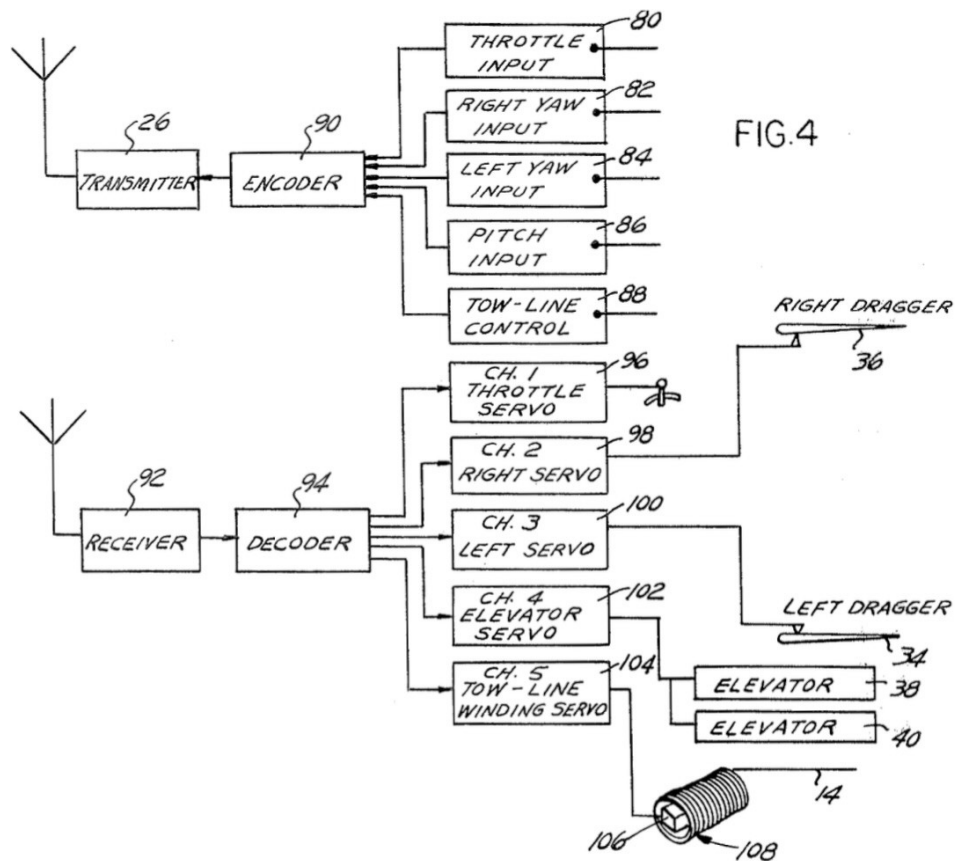

The input command signals, after encoding through an encoder 90 are transmitted, appropriately modulated, by the aerial of the transmitter 26 and received by the aerial of an appropriately attuned receiver 92 mounted on the tractor aircraft. After decoding through a decoder 94, the command signals are separated and applied to the input of the appropriate servos. The throttle position command signals are applied to the throttle servo 96 which operates the engine throttle, the right turn command signals operate a right turn servo 98 which operates the appropriate dragger, the left turn command signals operate a left turn servo 100 which operates the appropriate dragger controlling left turns. The pitch control command signal operates an elevator servo 102 which operates in turn the elevators 38 and 40 in unison. The towline winding command signal activates a towline winding servo 104 which triggers the start of a motor 106 driving a small winch 108 adapted to rewind the towline 14 prior to landing the towing aircraft.

FIG. 5 schematically illustrates an example of towline winding winch 108 particularly well adapted for winding the towline 14 prior to



landing the tractor aircraft **12**. The winch **108** comprises a rotatable spool **110**, around which the towline **14** is wound, supported by a rotatable shaft **112** and driven through a releasable coupling **114**, or other appropriate connecting and disconnecting member, by the output shaft **116** of the winch drive motor **106**. In the example illustrated, the winch drive motor is a spring windup motor. Prior to takeoff of the tractor aircraft with a piloted hang glider in tow, an appropriate length of towline **14** is unwound from the spool **110**, after disengaging the coupling **114**. The spring, not shown, of the spring windup motor **106** is wound, and the plunger **118** of a solenoid **120** defining the towline winch servo **104** is engaged into an appropriate recess **122**, or other abutment means, formed in one of the gears or toothed wheels **24** of the gear train of the spring windup motor **106**, between the spring actuated shaft and the output shaft **116**. The spring windup motor **106** is thus prevented from unwinding. After an appropriate length of towline is pulled through the towline support and guide **72** (FIGS. **2** and **3**), the coupling **114** is re-engaged, thus coupling the spool **110** through the shaft **112** to the locked output shaft **116** of the spring windup motor **106**.

After towing the piloted hang glider to altitude, if it is desired to retract the towline **14** after launching of the hang glider and prior to landing the tractor aircraft **12**, the towline control input **88**, FIG. **4**, is operated at the transmitter end, which in turn operates the towline winding servo **104**, or solenoid **120**, FIG. **b**, causing the solenoid plunger **118** to retract from the opening **122** in the toothed wheel **124** of the spring windup motor **106**, thus enabling the spring windup motor to drive, through its output shaft **116** and the coupling **114**, the towline winding spool **110**.

Driving means other than a spring windup motor may be used, such as for example a stalled DC motor which would dispense with a servo as it would be capable of automatically driving the winch spool **110** as soon as the towed hang glider is launched and no longer exerts a pull on the end of the towline **14**. A stalled windup spring motor could

also be used in the same manner. Alternatively, the towline winding servo **104** could operate the on-off switch of an electric motor.

For better maneuverability of the tractor aircraft, the point of attachment of the towline **14**, which corresponds substantially to the axis **74** of vertical pivoting of the towline support and guide tubular member **72**, FIG. **2**, and to the axis of the windup spool **110** of the winch **108**, FIG. **5**, is located at the coinciding center of gravity and center of lift of the wings of the tractor aircraft.

An example of hitch mechanism for attaching to the hang glider the end of the towline **14** is represented at FIG. **6**. As is well known, hang gliders are controlled by means of a control bar **130** which is attached to the bottom of or made integral with, as illustrated, a pair of symmetrically disposed support bars **132**, such that the control bar **130** and support bars **132** form a generally isosceles triangle. The other ends or tops of the support bars **132** are attached by means of appropriate mounting brackets **133** to the wing keel **134** of the hang glider, as shown at FIG. **6**, and generally also to the wing main spar or brace **136** according to the type of wing construction used by the glider. The control bar **130** is further braced by means of cables, not shown, to diverse portions of the wing. The present invention contemplates attaching to the three corners of the triangle formed by the bars **132** and **130** a tow hitch structure **138** consisting of three cables **140** of substantially equal length having an end attached to each apex of the control bar triangle, the cables **140** forming the corners of a pyramid interconnected at the vertex of the pyramid to form a loop or ring **142** permanently attached through an integral half-ring **144**, for example, to a controllably releasable clasp **146**. The releasable clasp **146** comprises a housing **148** having an integral bifurcated projection **150** on the side thereof opposite the side provided with the half loop **144**. A generally semi-circular loop member **152** has an end disposed between the side walls of the bifurcated side projection **150** and is hingedly attached thereto by means of a pivot pin **154**. The other end of the pivotable half loop member **152** is provided with a lateral bore **156** which is aligned with

a longitudinal bore **158** formed in the housing **148** when the clasp **146** is closed, that is with the side surface of the end of the half loop **152** provided with the bore **156** in engagement with the end of the housing **148**. A plunger **160** is urged by a compressed coil spring **162** disposed in an enlarged portion of the bore **158**, in the direction causing the end of the plunger **160** to project within the bore **156**, thus locking the half loop member **152** in a closed position, a shoulder portion **164** of the plunger **160** engaging an annular surface in the bore **156** separating the reduced diameter portion thereof from the enlarged diameter portion thereof. The coil spring **162** is held in compression by means of a fitting **165** threading into the end of the enlarged portion of the bore **156**. The fitting **165** is tubular to afford a passage for a flexible steel cable **166** provided with a flexible tubular sheath **168**, the end of the cable **166** passing also through the coil spring **162** and being attached to the enlarged end **164** of the plunger **160**. When a pull is exerted on the inner cable **166**, the pin **160** is withdrawn from the bore **156**, thus freeing the half loop member **152** to permit it to pivot freely around the pivot pin **154** such as to free the towline **14** having an appropriate looped end **170** through which the body of the half loop member **152** is passed when in a latched position. Opening of the clasp **146** may be aided by means of a spring, not shown, disposed at the pivot point of the half loop member **152** and urging it in the open position.

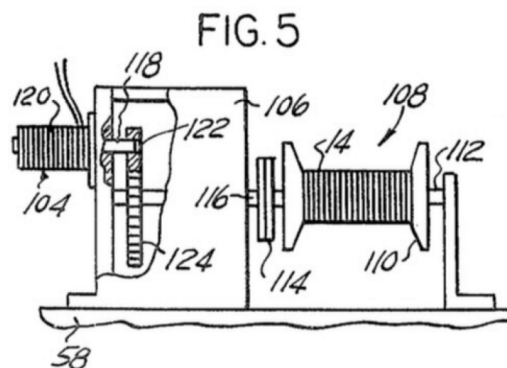

Opening of the hitching clasp **146** to release the towed hang glider for free flight is under the control of the hang glider pilot by means of a release lever **172** clamped on the control bar **130** or, if so desired, on one of the support bars **132** of the control bar and manually squeezed

by the hang glider pilot any time he desires to disconnect from the towline **14**. Squeezing the handle **172** towards the control bar **130** pulls on a flexible inner cable and withdraws the pin **160**, thus opening the clasp **146**.

Means, not shown, such as appropriate cables may be used to support the clasp **146** after unhitching, such as to not interfere with the hang glider pilot's action during flight and during landing, or, in the alternative, the whole assembly consisting of the hitch clasp **146** and the mounting cables **140** may be made jettisonable.

It will be appreciated that the releasable hitch clasp of FIG. **6** is given only for illustrative purpose, and that other mechanisms, such as those presently available on the market for releasing a hang glider being towed by a motor vehicle, motor boat, or ground vehicle may be used for the purpose of controllably releasing the hang glider under tow according to the teachings of the present invention.

The engine used to motorize the towing aircraft **12** of FIGS. **1–3** is preferably a small, light two-cycle air-cooled gasoline engine of about 25–35 hp. A plurality of engines suitable for the purpose of the invention are available on the market, such as engines used to propel snowmobiles. The power unit including the engine, fuel, the housing **48**, and the tricycle landing gear **42** can be supplied in the form of a module, which may also include the radio receiver and the control servos, which is bolted on and disconnected from the wings relatively rapidly and without any special skills. The module unit has a total weight, of about 150–170 lbs., that is not more than the weight of a pilot of normal weight, and much less than the combined weight of a pilot and of the power unit used to motorize hang gliders, with the result that the speed envelope of the tractor aircraft matches the speed envelope of the towed piloted hang glider, and that the rates of climb of the two flying machines are perfectly matched. The total weight of the tractor aircraft is about 210 lbs.

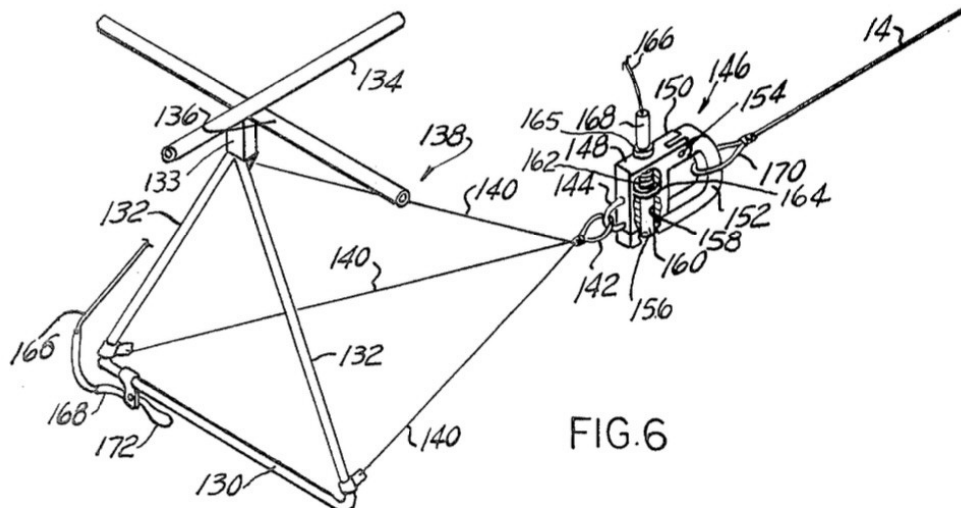

Having thus described the present invention by way of examples of structure there of, modifications will be apparent to those skilled in the art, what is claimed as new is as follows:

1. A pilotless powered aircraft for towing a piloted motorless aircraft by means of a towline, said pilotless powered aircraft comprising a lifting surface, a yaw control surface and a pitch control surface, a thrust-providing power unit attached to said lifting surface, and a radio control receiver for operating said thrust-providing power unit, said yaw control surface and said pitch control surface as a function of command signals remotely transmitted from the ground by means of a radio transmitter, and means under the control of the pilot of said piloted motorless aircraft for releasing said towline, wherein the range of minimum to maximum flying speed of one of said aircraft overlaps substantially the range of minimum to maximum flying speed of the other of said aircraft, wherein said towline is stressed to break as a result of a pulling force exerted thereon in the range of about 1.5 to 3 times the maximum thrust exerted by said thrust-providing power unit, and wherein said piloted motorless aircraft is a hang glider and the lifting surface of said pilotless powered aircraft is a hang glider.
2. The combination of claim 1 wherein said pilotless powered aircraft is provided with a tricycle landing gear undercarriage.
3. The combination of claim 1 wherein said thrust-providing power unit is a gasoline engine driving a pair of contra-rotating pusher

propellers.

4. The combination of claim **1** further comprising power winch means mounted on said pilotless powered aircraft for winding up said towline after release of said motorless aircraft.
5. The combination of claim **4** further comprising servo control means controllable by said radio receiver upon receiving an appropriate command signal for starting the operation of said power winch means.
6. The combination of claim **4** wherein said winch means is powered by a spring windup motor.
7. The combination of claim **1** wherein the minimum flying speed of both said aircraft is comprised between about 15 and 25 mph.
8. The combination of claim **1** wherein said towline is attached to said pilotless powered aircraft at the center of gravity of said pilotless powered aircraft.
9. A method of towing a piloted motorless aircraft by means of a powered aircraft provided with a thrust-providing power unit, said method comprising connecting said powered aircraft to said piloted motorless aircraft by means of a releasable towline, towing said piloted motorless aircraft to altitude by said powered aircraft, controlling said powered aircraft from the ground by means of a remote radio-controlled link, and releasing said towline from said piloted motorless aircraft when reaching an appropriate altitude, said releasing of said towline being effected by the pilot of said piloted motorless aircraft, wherein the range of minimum to maximum flying speed of one of said aircraft overlaps the range of minimum to maximum flying speed of the other of said aircraft and said towline is arranged to break upon a pull exerted thereon which is about 1.5 to 3 times the pull exerted by said powered aircraft power unit and wherein said piloted motorless aircraft is a hang glider and said powered aircraft has a hang glider lifting surface equipped with said thrust-providing power unit.
10. The method of claim **9** wherein the minimum flying speed of both said aircraft is comprised between about 15 and 25 mph.

11. The method of claim 9 further comprising retracting said towline after release of said towline.
12. The method of claim 9 wherein said thrust-providing power unit is a gasoline engine driving a pair of contra-rotating pusher propellers.
13. The method of claim 9 wherein said towline is attached to said pilotless powered aircraft at the center of gravity of said pilotless powered aircraft.

<b>UNITED STATES PATENT AND TRADEMARK OFFICE</b> <b>CERTIFICATE OF CORRECTION</b>	
PATENT NO. : 4,248,394	
DATED : February 3, 1981	
INVENTOR(S) : Marlin K. Klumpp	
It is certified that error appears in the above-identified patent and that said Letters Patent are hereby corrected as shown below:	
Column 7, line 44, change "24" to --124--.	
[SEAL]	<b>Signed and Sealed this</b> <i>Twenty-eighth</i> <b>Day of</b> <i>July</i> 1981
Attest:	
Attesting Officer	GERALD J. MOSSINGHOFF <i>Commissioner of Patents and Trademarks</i>

## Resources

- [US Patent and Trademark Office](#) (USPTO) – The USPTO provides an outstanding search engine which enables digging through (seemingly) every patent in their office. Proceed with caution – you could easily spend **days** of your time digging through their utterly fascinating files.
- [US Patent 4,248,394](#) – A PDF of the original patent as downloaded from the USPTO website, on which this article is based.

Read the [next article](#) in this issue, return to the [previous article](#) in this issue or go to the [table of contents](#). A PDF version of this article, or the entire issue, is available [upon request](#).

## Rediscovering Martin Simons



Martin Simons has written three books about model aircraft. Each has a definite target reader. See Resources below for suggestions as to where they can be obtained.

### Part IV: Center of gravity as discussed in the noted author's model aircraft books.

*In the first three parts of this series (see Resources below for links), we examined Martin Simons' Slingsby Sailplanes. Now we continue with a closer look at his volumes related to model aircraft. Excerpts are reprinted with kind permission of the Simons family. We start with comments from curator Peter Scott and then follow with the text and images from Martin's books. — Ed.*

Martin Simons has written three books about model aircraft. Each has a definite target reader:

- ***Gliding with Radio Control*** from 2002 is for the beginner, covering all areas of the field including types of model, radio gear including installation, and how to fly. Starters will probably do well to read it from front to back and make their own. Of course some of the



technical aspects of the electronics are out of date. The glossary will help newcomers to grasp all the new words. There is no index but the table of contents will help readers find what they want.

- ***Model Flight*** from 1988 is more advanced, with theory to give the developing flyer a better understanding of how models fly. There is an excellent index that refers to paragraph numbers rather than page numbers.
- ***Model Aircraft Aerodynamics*** from 1978 is hardcore for those who want to know the ideas in depth and possibly design their own models. It has an excellent index but that refers to a numbered paragraph rather than a page. It is a substantial work and when first written perhaps the software used did not handle indexes as well as it now does? Paragraph numbering makes assembling and editing a large work much simpler. For the real lovers of the maths and technical side there are two appendices of those topics, a third of aerofoil information and references and a fourth which is a booklist. Overall it is an outstanding piece of work.

I wondered how best to give you a taste of these excellent books and decided to pick on topics that have interested me lately and show how each book tackles them. The topics I chose are: centre of gravity (CG), turbulators and winglets.

CG is of special interest due to my glider experiments, which have given me a club reputation as a nutter. I like to point out that my gliders now fly rather well, though they are not useful for training as they are less stable. I have based those ideas on an excellent article by Brian Agnew in the 1997 Radio Control Soaring Digest. I haven't used a turbulator since I stopped flying free-flight A/2 FAI gliders decades ago but always wondered how they worked. All of my newer gliders have winglets.

Martin's text and pictures will hopefully teach you something you didn't know. It will also give you a feel for the level of the books so you will be able to help club members and friends choose which one is best for them. For this article I will add Martin's work on centre of

gravity. I hope he will approve my choice of text. The other elements – turbulators and winglets – will be the subject of future articles here in the New RCSD.

Quite correctly Martin has set aside any extreme ideas about this matter, and covers it thoroughly and conventionally. My power scale model mates always fly with a forward CG and Martin's explanation of how that works with small scale tailplanes got me to understand at last. Starting below the grey line (and up until the final grey line) all text and images are from Martin's books, except my balance stand and my *[italicised bracketed comments]*.

---

## From Gliding With Radio Control

The most important thing when the glider is completed with all the radio gear installed, controls connected and working correctly, warps removed etc., is to make sure the centre of gravity or balance point is in the right place. Probably more new models crash from neglect of this than all other causes.

On a good plan, there will be a clearly marked position for the centre of gravity or CG. If, when otherwise completed, the model does not balance **at or in front of** this point, trimming ballast must be added to the nose. One reason for keeping the tail end of a glider as light as possible is to avoid having to balance it by filling up the front with large amounts of ballast. Placing the battery, servos and receiver as far forward as possible helps to ensure that the CG will come out somewhere near the right place, but this is hardly ever enough.

If the plan does not show it, the CG should be **between one-quarter and one-third** of the **average** distance between the leading edge and trailing edge of the wing. In many cases, this will be **on, or in front of, the main spar**. A rough first check can be made by supporting the model with two fingers, one under each wing. The tips of the fingers should be fairly well apart when this is done, slightly less than half the total span ie about two-fifths of the way out towards the tips (this

method works even if the wing has some sweepback, since the effective aerodynamic centre of each wing half is very roughly at the 40–45% spanwise point).

The aim is to get the glider to balance horizontally when the support points are between one-quarter and one-third of the chord measuring from the leading edge. Add nose ballast until the glider takes up a horizontal position when supported in this way. A little nose heaviness is not a bad thing. It makes for *increased safety* if the CG is a little further forward than the plan shows. It is **DANGEROUS** to have the balance point even slightly too far back.

More accurate measurements can be taken by making a simple wooden support of the kind shown in the diagram (Fig 10.1).

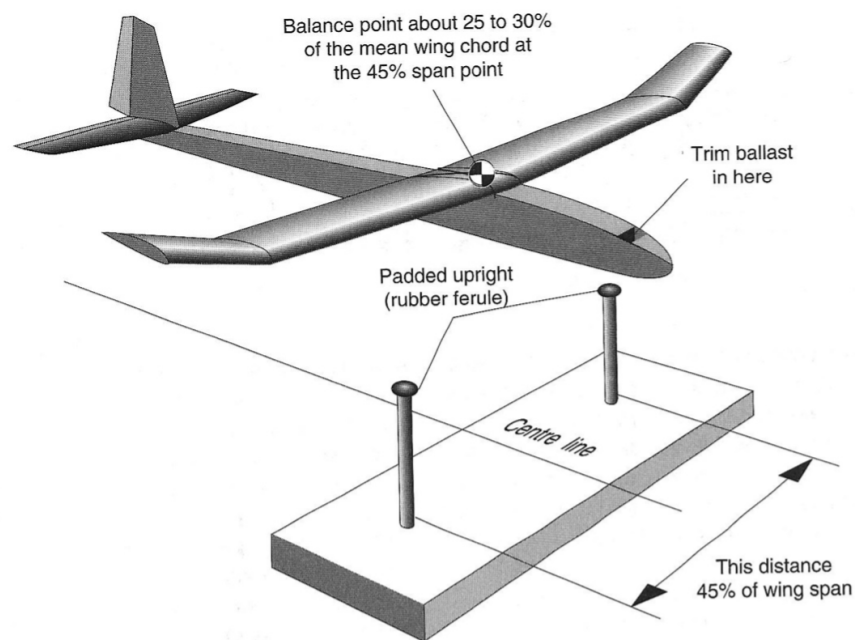
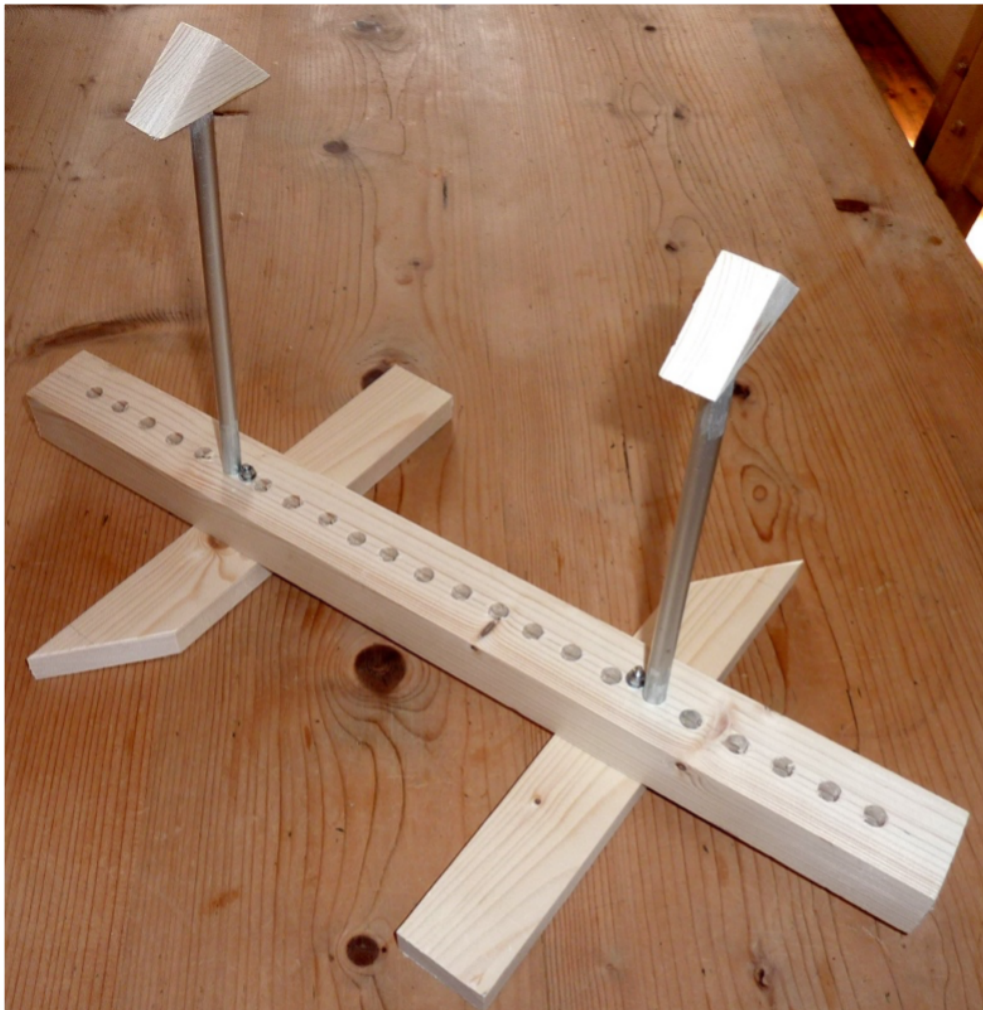

Fig 10.1

A rearward position of the balance point makes any aircraft, glider or aeroplane, full sized or model, unstable and 'twitchy' in response to the controls. On the other hand, balancing the model well forward reduces the sensitivity and makes for gentle and smooth response. A very experienced pilot may actually like a model which leaps instantly about in response to the merest feather touch but for a beginner this is disastrous. After some successful flying with the CG safely forward,

it is worth a little experimenting with balance points to see how much difference it makes to add, or subtract, nose weight. The pilot then can adjust the stability and responsiveness to whatever is preferred. It is incorrect to suppose that moving the CG aft beyond about 35% improves the performance of the model. All it does is to make the elevator more twitchy and the model less stable in flight. If anything it tends to increase drag and hence take a slight edge off the performance.

*[Here is an alternative folding CG stand made out of scrap by yours truly. The angled cuts on the feet are to extend the footprint.]*



(credit: Peter Scott)

---

## From Model Flight

### 5.4 Centre of gravity location

As the angle of attack of the aircraft changes in response to gusts etc., at a given flight speed, the resulting variation of lift force is felt at the neutral point. An increase in angle of attack produces an increase of the lift force and a reduction of the angle produces a reduction of the lift. The pitching stability of an aircraft is almost entirely determined by the position of the centre of gravity in relation to the neutral point where these changes of lift force act. Any surface, such as wing, forewing, or fuselage, which has its aerodynamic centre ahead of the centre of gravity tends to destabilise the model, and any such surface aft of the c.g., tends to stabilise it.

Almost all pitch stability and elevator control problems can therefore be overcome by *adjustment of the centre of gravity position*. It is very easy to change the centre of gravity, much harder to alter the neutral point position since this involves changing the areas of wings and stabiliser, and perhaps altering the length of the fuselage.

Moving the c.g. forward, by adding ballast to the nose of the model, increases stability. Moving the c.g. aft reduces stability and, if carried too far, can produce serious instability. The pilot should experiment with c.g. position to find the degree of elevator response that suits the model and the pilot's taste. There is no single answer. The pilot's preference is the decisive factor.

Every change of c.g. position requires readjustment of the elevator trim for straight and level flight (Figure 5.6). Moving the c.g. forward increases the total nose down pitching moment. This is balanced out by setting the elevator and/or stabiliser at a new angle, i.e., adding nose up trim. *This change does not shift the neutral point.* In the same way, moving the c.g. aft requires a different elevator angle, without altering the neutral point location.

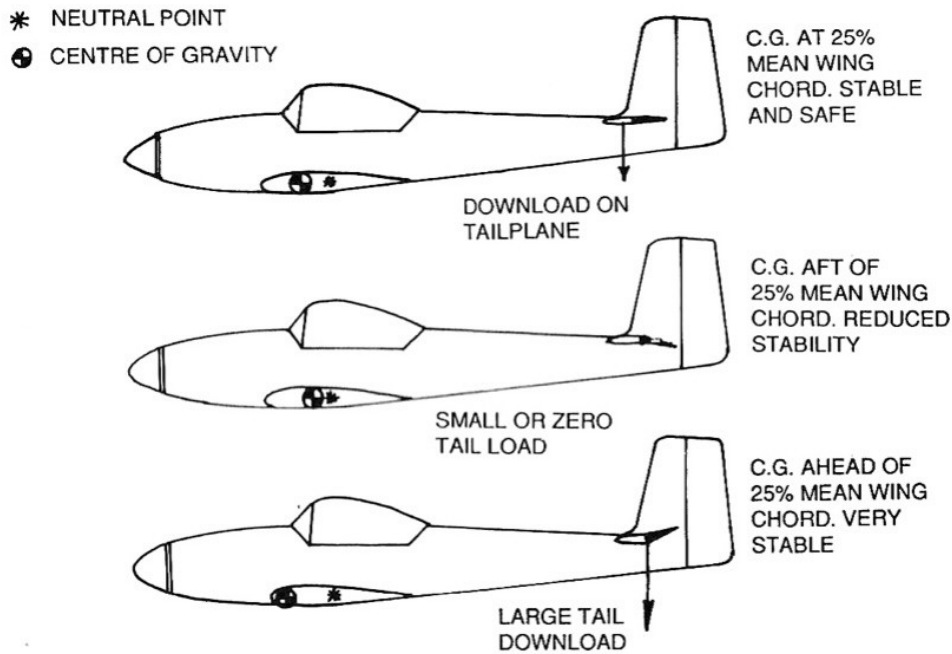

Figure 5.6 C.G. Location and stability in pitch

It must be emphasised again that altering angles of incidence and elevator trim does not change the location of the neutral point, although changes of centre of gravity position do require new trim settings. Putting this the other way round, if a model is unstable in pitch, or too stable, altering the angular settings will not improve the situation. The centre of gravity should be adjusted, *after* which trim changes will be required.

With orthodox aircraft, if the centre of gravity is located exactly at the 25% mean chord point of the wing, as it often is, a small tailplane will provide adequate stability and will easily trim out the pitching moments to ensure balance. Such a placement renders the wing neutral in stability, so the small tailplane, well aft of the centre of gravity, is a powerful stabilising surface and does not have to fight against the wing during any disturbance.

If the c.g. is aft of the 25% mean wing chord position the wing will tend to destabilise the model. A larger tailplane will be required to counteract this. This is a common arrangement with model aircraft. Very frequently, the c.g. is placed at about 30 to 35% of the mean wing chord. The tailplane then has to be enlarged to give adequate stability. In most cases, a more forward c.g. with smaller tail (of similar

efficiency) would be equally satisfactory. A small tailplane with c.g. at 25% of the mean wing chord gives the same static stability in pitch as a larger tailplane with c.g. at 35%. (See the discussion of *static margin*, section 5.7 below.) Putting this, too, another way, if a model is not stable enough, increasing the tailplane area will make it more stable but moving the c.g. forward will have the same effect, with less trouble.

If the c.g. is ahead of the wing quarter chord point, stability will increase. Flight in this forward c.g. trim is very safe except that it may tend towards the over-stable condition. To prevent this, the tailplane may be reduced in area. This kind of arrangement has enabled some scale models of full-sized aircraft with very small tails to be made more stable. *[This is probably why club members who fly accurate scale models use a forward CG.]*

---

## From Model Aircraft Aerodynamics

*[As you might expect, in this book Martin takes a much deeper view of CG and stability. He approaches it from the ideas of the neutral point and static margin.]*

### 12.15 THE NEUTRAL POINT

As described previously, every wing or wing-like surface in an airstream at a moderate angle of attack has an aerodynamic centre close to the quarter chord point. This applies to fins, tailplanes, fore planes and such streamlined shapes as struts, wheel spats, nacelles, faired undercarriage axles, etc, etc. Even long, slender forms such as arrow shafts or fuselages have an aerodynamic centre and this is normally close to the quarter length position for moderate angles of attack.

If the structure of a model is fairly stiff, it may be treated as a fully rigid body. Then it is possible to regard the entire aircraft as one object which produces lift and drag at some fixed point equivalent to

the aerodynamic centre of the whole. The exact position of this point may be found by locating the aerodynamic centre of each separate component first, then, with an allowance for the efficiency of each part as a producer of aerodynamic force (area, angle of attack, body shape etc, and whether or not in the wake of another component), the total effect of all may be added and the aerodynamic centre of the entire aircraft found. As with a wing, providing the airflow is not generally separating, the centre of forces so found remains in one place at all useable flight attitudes.

It has already been pointed out that, for a model to be in trim, the total of all pitching moments on it, at any place on the fore and aft centre line, must be zero. Hence, when the aerodynamic centre of the airplane is located, if it is in trim the pitching moments of all the various components will total zero at this point.

For stability in the longitudinal sense, rotations about the Y-axis, it is necessary that if there is a disturbance of equilibrium, causing a nose-down or a nose-up pitch, then a corrective pitching moment should appear. A noseup disturbance causing an increase of the total lift force at the aerodynamic centre of the model must automatically produce a nose-down moment, and vice versa, a nose-down upset must produce a nose-up response.

An unstable aircraft will produce the reverse; a noseup pitch will produce a nose-up moment, making the situation worse, and again, vice versa.

A neutrally stable aircraft, when pitched either way will produce no correction force, leaving the attitude to be determined by chance gusts and random disturbances of the air. *[Earlier]* a symmetrical wing was shown, in trim, with zero pitching moment and the centre of gravity exactly at the aerodynamic centre of the wing. A disturbance of such a wing would produce no pitching moment in either direction because symmetrical wings have no pitching moment (unless stalled). Evidently, the condition of neutral stability for an entire



aircraft just described is exactly similar; no corrective force arises either way if the model pitches.

Figure 12.10 shows the results if the centre of gravity of any airplane or glider is at, behind or in front of the neutral point in a disturbance.

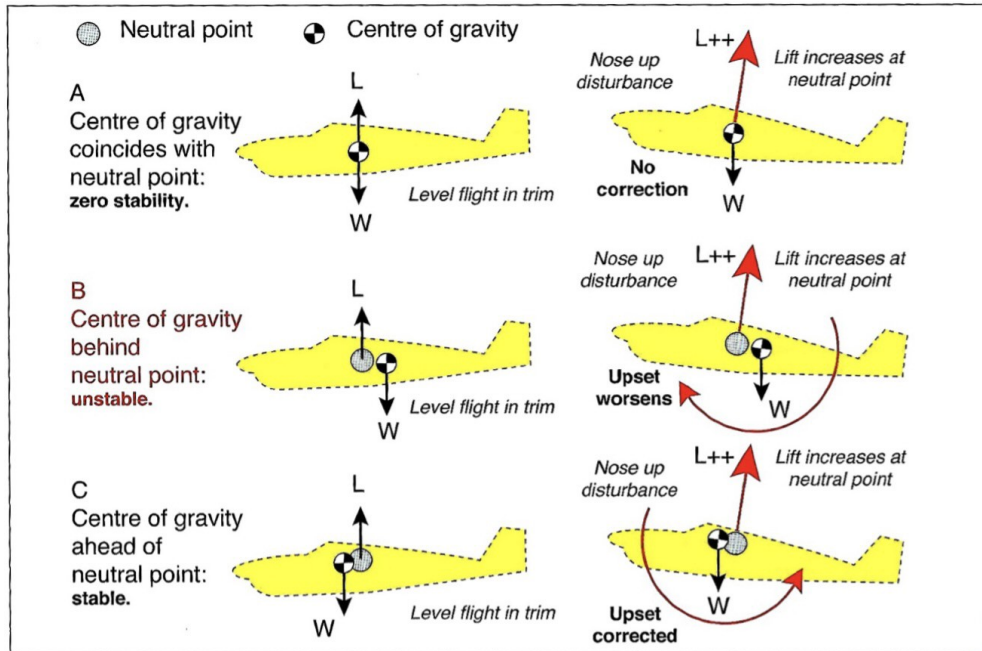

Figure 12.10

In Fig. 12.10A the centre of gravity is at the neutral point. A gust throwing the model into a climbing attitude causes an increase of the total lift force on the whole model. The centre of gravity and lift are still acting at the neutral point and no pitching moment results. There is nothing to make the model rotate in either direction. It will stay nose up until another gust happens to change it to something else. With a nose-down upset, again, there is no corrective force. If the centre of gravity is at the aerodynamic centre of the entire aircraft, neutral static stability is the result. For this reason, the aerodynamic centre of an airplane is termed the neutral point.

In Figure 12.10B, the centre of gravity is aft of the neutral point. Now a nose-up disturbance produces an increase in lift ahead of the centre of gravity and this produces a nose-up pitching moment. Vice versa for the nose-down disturbance; the lift is reduced and the nose-down pitch is worsened. To locate the centre of gravity of a model behind

the neutral point produces instability. Any disturbance is immediately made worse.

It follows that for static stability the situation of Figure 12.10C is essential. The centre of gravity of the aircraft must be in front of the neutral point. Then a nose-up disturbance produces an increase of lift behind the centre of gravity and this tends to restore the normal trimmed and balanced flight attitude. A nose-down change produces a decrease of the lift aft of the centre of gravity, and a nose-up moment arises. This applies to all model layouts, as in Figure 12.11.

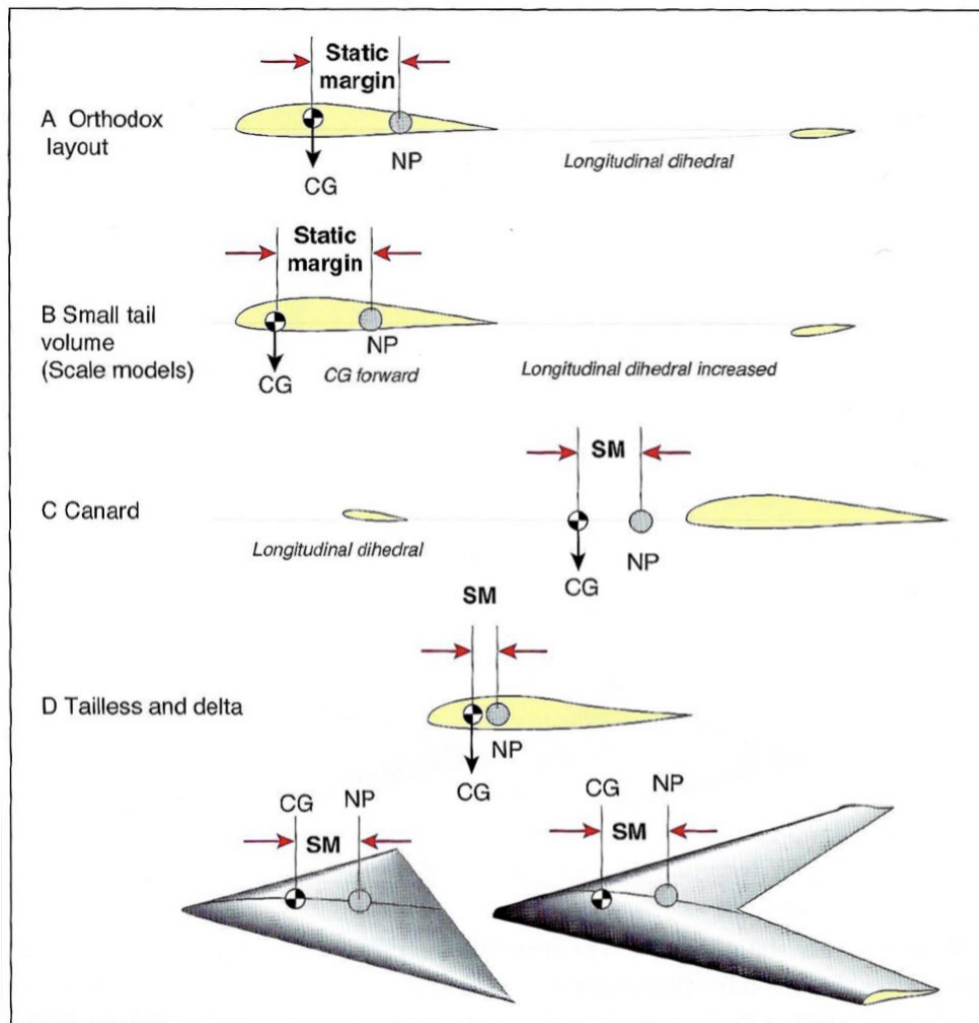

Fig 12.11

## 12.16 THE STATIC MARGIN

The distance between the centre of gravity and the neutral point is termed the static margin of the aircraft. It gives a very useful standard of comparison of one aircraft with another, since if they have similar

static margins they will have similar static stability. The larger the margin, the greater the stability. This concept also brings into prominence the fact that a shift of the centre of gravity of any model aircraft will change the stability margin. By this very simple means a dangerously unstable model can be made stable, or an over-stable one made more sensitive and responsive. Stability is thus almost entirely under the control of the model flyer and can be varied, within limits, by the addition or subtraction of ballast at nose or tail [*or battery movement*]. Any such change of ballast will require a new elevator trim setting for level flight.

©1978, 1988, 2002 Martin Simons

---

## Resources

*Note that Model Aircraft Aerodynamics can be bought new from all the usual places. For the other two books you could try AbeBooks or similar or possibly your local secondhand book shop:*

## The Trailing Edge



Bob Jennings' beautiful Nimrod appears to fly off into the sunset over the Great Orme in North Wales, UK. This great shot was taken at the Power Scale Soaring Association's October, 2022. event. (credit: Phil Cooke)

## The Ed is crabby again.

He always is, a few days before deadline. In fact, you could set your watch by it. We're not sure, but we think we can hear him muttering, almost inaudibly "that's it, that's my last issue!" except he inserts *that word* in between every pair of words. His guidance and instructions are just about polite, but terse. We think you get the picture, and it ain't too pretty.

Then, surprisingly, as deadline ticks ever closer, his mood begins to lift. It's as the issue begins to take shape — where the sequence and flow has emerged and the final product is now inevitably going to make the deadline. It's down to steadily checking items off the to-do list. We know we're that close (pinching fingers together) when he begins to hum that infernal Looney Tunes theme. Ironically, he only knows one line and we don't have the heart to tell him he has it wrong:

“No more hearsing, than hearsing apart...”

Finally, like the white smoke appearing above the Vatican, the New RCSD flag is raised over the home office and we have a new issue. To say the process is weird is an understatement, but 23 issues into the new papacy, it does seem to work, surprisingly.



Bob Jennings and his magnificent Nimrod at the Avro Heritage Museum at Woodford, England. All of the real Nimrods, the nose of one which is pictured on the right, were manufactured at this location. (credit: Phil Cooke)

Between us, there have been some professional setbacks for The Ed over the years, with things not always working out quite the way he had hoped. But particularly when he's in air traffic control mode working with the contributors in these final days before the new number hits the streets, there's a unmistakable, focused gleam in his eye that gives us the impression he has finally arrived where he truly wants to be.

But also between us, he can lose the crabbiness any time.

## New in The RCSD Shop



The November 2022 edition of the [New RC Soaring Digest Cover Photo T-Shirt](#) featuring photography by Martin Pilný.

For the November 2022 issue we featured this elegant, contemplative cover photo taken by Martin Pilný at a local F3G competition held in Litomyšl in the Czech Republic on 9th of July, 2022. It shows Vašek Vojtíšek checking the weather conditions before the start of the next round of the competition. [Order yours today.](#)

All items in the Shop are made especially for you as soon as you place an order, which is why they are fairly priced and it takes us a bit longer to deliver them to you. Making products on demand instead of in bulk helps reduce overproduction and waste. Everybody wins.

Thank you for making thoughtful purchasing decisions and also helping to support the New RCSD!

## Make Sure You Don't Miss the New Issue

You really don't want to miss the December issue of RCSD when it's out – we always have some exciting things in the works. Make sure you connect with us on [Facebook](#), [Instagram](#), [Twitter](#) or [LinkedIn](#) or subscribe to our [Groups.io](#) mailing list. Please share RCSD with your friends – we would love to have them as readers, too.

That's it for this month...now get out there and fly!

©2022