



Radio Controlled  
**Soaring Digest**

August 2022

Vol. 37, No. 8



# The New RC Soaring Digest

August, 2022  
Vol. 37, No. 8

Title	Subtitle	Page
In The Air	So just how big is the RC soaring community?	3
Letters to the Editor	It looks like a perfectly sane idea to us, Waid.	8
Cool New Stuff	Our monthly round-up of new products which have caught our eye.	12
RC Soaring in Türkiye	A snapshot of recreational flying activity at 'the crossroads of Europe and Asia'.	16
The Slingsby King Kite	Part II: More Empennage Design and Construction Details	28
My Slope Flying Sojourn in the UK	Aviation nirvana awaits on 'this sceptred isle'.	34
Rediscovering Martin Simons	Part I: A short primer on the man and thence to 'Slingsby Sailplanes'	44
How Many Degrees in a (GPS) Triangle?	Part I: Yes, Iain, it is all your fault.	57
Landing On!	(not landing out)	61
Soaring the Sky Podcast	E076: Mountains, Mishaps and Milestones	73
Electricity for Model Flyers	Part IX: Telemetry	75
Club in Focus	Southern Ontario Glider Group Inc. (SOGGI)	88
Tiny Offset Screwdriver	When you need to MacGyver yourself out of a tight spot.	94
The Saga of the Sperry Special	Neither the Ellensburg librarian nor Dad could deter the nascent aeronaut.	97
Stamps That Tell a Story	A tribute to Ernő Rubik's classic Futár and Cimborá designs.	105
Glider Patents	US 2018/0086449 A1: Single Use Logistical Glider	108
The Trailing Edge	Wasps.	138

Click on any row to go directly to that article.

## In The Air



Gary Quiring's brand new Pulsar 3.6m aloft early in the morning at Bowman, South Carolina. Gary reports that its first flight presented no issues. He equipped it with GliderDrive, YEP ESC, KST servos and a Horus X10s with G-RX8 receiver. Looks like it's headed right to lunar orbit.

## So just how big is the RC soaring community?

Quite often, I'm asked "so exactly how many people are into that RC soaring thing?" In response, I'm forced to fake a coughing fit, mumble something unintelligible, do a spit take or perhaps just pretend I don't quite understand the question. In other words, just about anything other than provide a straight answer.

That's because I don't know.

And when I say I don't know, I mean I *really* don't know. I'm not sure anybody does. I can make some educated guesses, but that's about it. For a ton of reasons beyond the scope of this column, that's not a happy state of affairs. There are, however, some tantalising clues — here are just a few that provide some interesting if not complete insight:



- **New RC Soaring Digest Analytics** – As noted previously, RCSD collects GDPR-compliant analytics which help to understand the audience so that the team can continually improve the product we deliver to you, the reader. We analyse that data in a variety of ways but the one number which seems relevant here is that we've had nearly 100,000 visitors since RCSD relaunched. However, because we respect our readers privacy, we can't actually tell if that's one reader visiting 100,000 times, or 100,000 readers visiting once. But the actual number of readers would seem to be somewhere between those two extremes, of course.
- **John Woodfield RC Gliders** – John's superbly entertaining and beautifully produced YouTube channel (see *Resources*) currently reports 40,900 subscribers and grows steadily. His frequently released videos – where does he find the time! – typically have view numbers in the 5,000 to 10,000 range. Quite a few rack up tens of thousands of views, some hundreds of thousands and at least one from a year ago, a whopping 1.5 *million*. But like RCSD's analytics, 'views' may not mean as much as you think. A human watched at least 30 seconds and, yes, it could be one human viewed 30 seconds 1.5 million times.
- **RC Glider Universe** – For those of you who haven't found it yet (it's also linked below) this is one of the premier groups catering to the RC soaring community. It can be found on the social platform everybody loves to hate, Facebook. They are currently reporting 14,200 members. But what's less clear is what percentage of these members are active. More on that in a moment.

There are some additional factors which have to be considered. The metrics above all assume a wired up community – that is, connected to the internet and accessing one of these services amongst others. If there is some vast number of RC glider guiders out there who *never* use one of these services then they're going uncounted. In this day and age, you wouldn't think that's all that many but it's definitely a 'known unknown'.

All of these metrics have one additional, really significant flaw – they don't distinguish between 'interested' and 'involved'. To better understand what that means, think about the example of eggs and bacon. The chicken was interested but the pig was, well, *involved*.

What percentage of these communities are real living, breathing human beings with a glider project on the go? Without even getting into the whole bot and fake account hornets' nest (which is also a problem) you might want to ask yourself about the electronic communities to which you belong: how many living, breathing, actually-building-and-flying-something seem to be on the platform? I'll wager it's a tiny, *tiny* fraction of the total number of members of that community.

So what do you think? How many people do you believe are actively pursuing the hobby around the world? Do you have any hard data about the size of the RC soaring community that you would be willing to share with our readers? If so, by all means, get in touch – we'd love to see it and share it!

## Flying Field Updates from Alberta and South Carolina

The subtitle for last month's column was *Flying fields are as fragile as spring blossoms* (see below). In it I told the stories of two clubs which had been summarily tossed off their flying fields. One of them was the Leduc Alberta Radio Control Society (LARCS) which had suffered the loss of their flying field "effective midnight...April 27, 2022. There is to be no flying at the site effective immediately." As a happy postscript to that story, the Zone 'A' Director Roger Ganley recently sent out the following:

LARCS (Leduc) found a replacement flying site and thanks to the 'Find A Field' committee and their crew it should be ready for use in the spring.



Similarly Gary Quiring, who provided the beautiful photo above, reports that he and his buddies have found accommodations in Bowman. Check out this month's *Letters to the Editor* for Gary's full story from South Carolina.

It's simply nice to know that despite things looking kind of bleak at the moment, at least anecdotally there still are stories out there with happy endings.

Until next month, fair winds and blue skies.

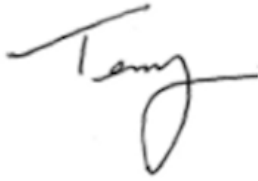
A handwritten signature in black ink, appearing to read 'Gary', with a stylized flourish at the end.

## Resources

- [John Woodfield RC Gliders](#) YouTube Channel – The most popular RC-related channel on YouTube? Unless you know of others? To find John's most popular videos, simply sort by popularity in descending order.
- [RC Glider Universe](#) – The largest Facebook group catering to the RC glider community that we have been able to find. Do you know of others, which perhaps are larger and/or more active?
- [In The Air: Flying fields are as fragile as spring blossoms.](#) – This is where you can find the full text of the LARCS announcement referenced above.
- [Composite RC Gliders](#) – “Our modern company specializes in the development, design, and manufacture of high-quality model airplanes made predominantly from composite materials featuring fiberglass and carbon fiber cloth.”

*Cover photo: This month's cover photo was provided by Werner Fehn of Composite RC Gliders, with our thanks. We have linked Werner's website in our Resources section above. You are welcome to*

download the July cover in a resolution suitable for computer monitor wallpaper (2560x1440).

***Disclaimer:** While all reasonable care is taken in the preparation of the contents of the New RC Soaring Digest, the publishers are not legally responsible for errors in its contents or for any loss arising from such errors, including loss resulting from the negligence of our staff.*

*Reliance placed upon the contents of the New RC Soaring Digest is solely at the readers' own risk.*

Here's the [first article](#) in the August, 2022 issue. Or go to the [table of contents](#) for all the other great articles. A PDF version of this edition of In The Air, or the entire issue, is available [upon request](#).

Unlisted



## Letters to the Editor



There are two new stamps in our montage this month – see if you can spot them. Here's a hint: they're the subject of Simine Short's 'Stamps That Tell a Story' in this issue.

**It looks like a perfectly sane idea to us, Waid.**

### My Latest RC Insanity

I attached a 64mm EDF to a 25-year old, semi-scale ASW-15 (82" span) I inherited from a friend who passed. I care sold these little slopers back in the nineties. I had a sister ship ASW-19 which flew great on the slope and could even thermal on a strong day. I flew this ASW once at Kiona Butte in the late nineties. It handled very well – similar to the -19.



We don't know which we like more: the plane or Waid's gorgeous (and spotless!) epoxy floor. — Ed.

Up until a couple weeks ago it had been in the box for over 20 years. Might be fun for aerobatics, as that EDF puts out some serious thrust on a 4S Lipo. Hope the tail can withstand the blast! I'll let you know what transpires if I ever manage to get the little beast into the air.

Waid Reynolds  
Green Valley, Arizona

*Can't wait to hear an update after you fly it for the first time! Please keep us posted and we'll be sure to include that in a future Letters. Thanks for sending it in, Waid. — Ed.*

## Update from South Carolina

I have been flying at my new location at Bowman, South Carolina. It's about a 70 minute trip, Eutawville was about 50 minutes. The first week was frustrating, I took a busy highway to get there and a truck tossed a stone into my van windshield. The windshield had to be replaced. So I won't be taking the highway anymore, I'm going local which is how Eutawville was. It's a longer ride that way but it's really nice to see a lot of farmland.

I stopped by the Eutawville field one day and it's 100% gone now. They plowed it over and it's been seeded with cotton. They moved very



quickly. It still shocks me that 92 acres of cotton and they wanted that last six acres we leased. And the owner of the field refused to give us back our 2022 money!

I got my Pulsar 3.6m full house completed these past few weeks and maiden at Bowman. It was uncomfortable, Eutawville was so large I used to always joke about the only thing you can hit out here is the ground. Bowman is still a decent size field but there are trees to contend with on both sides of the field. It's just a matter of getting used to the field. The maiden went well with no issues. I used a GliderDrive, YEP ESC, KST servos and a Horus X10s with G-RX8 receiver.



Gary's Pulsar on final approach at his new field at Bowman, South Carolina. – Ed.

The Bowman club president was very accommodating to Gene, Mark and myself which are his only sailplane members. He granted us permission to fly behind the flight line so we can stay out of the way of the power planes (lots of very large gassers). The club just completed a power station that uses a large truck battery with a 120v inverter that is charged by a solar panel. So we have power which was one of my big concerns. I was also allowed to drive a 2" PVC tube into the ground and brought the Eutawville umbrella over. So the sailplane guys will be flying in style! The only negative are the bugs, OMG it's been years since I flew at a field infested with them. I tried a few bug sprays but so far nothing works well.

I enclosed a photo of the Pulsar flying...on an early morning flight.

Gary Quiring

Eutawville, South Carolina

*Thanks for the update, Gary, and congratulations on a successful first flight! While it sounds like the new venue you've found that while not perfect, is at least being helpful in keeping you and your 'band of brothers' in the air. Perhaps there is a reader out there who can help Gary and his fellow glider guiders find a suitable field closer to home?*  
— Ed.

*Send your letter via email to [NewRCSoaringDigest@gmail.com](mailto:NewRCSoaringDigest@gmail.com) with the subject 'Letters to the Editor'. We are not obliged to publish any letter we receive and we reserve the right to edit your letter as we see fit to make it suitable for publication. We do not publish letters where the real identity of the author cannot be clearly established.*

*Read the [next article](#) in this issue, return to the [previous article](#) in this issue or go to the [table of contents](#). A PDF version of this article, or the entire issue, is available [upon request](#).*

Unlisted

## Cool New Stuff

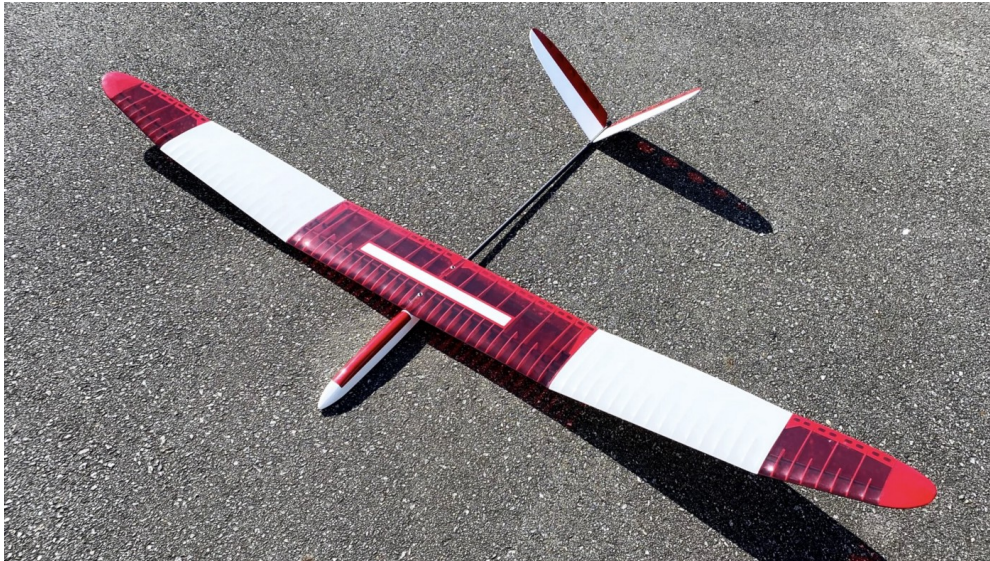

The Medina. (credit: ArmSoar)

**Our monthly round-up of new products which have caught our eye.**

### The Medina from ArmSoar

**A high-performance 2m F3L/F5L kit for those who will always believe 'balsa flies better'.**

Want to enjoy the performance and ease of flying of the 2-meter *Medina* RC glider, but prefer to do the build yourself? The *Medina* from ArmSoar kit is out now. It includes hardware for the *Medina* to be built for either F3L (pure glider) or F5L (electric). In case you're wondering, these designations were formally known as F3RES and F5RES which in turn, is an abbreviation for rudder-elevator-spoilers. In other words, good old simple flying which some say is still the best.

Created in partnership with Performance Models in Australia, the *Medina* uses new airfoils purpose-designed for the flight envelope of modern F3L/F5L competition flying. The wingtips are specifically

optimised for great tip-stalling characteristics and could handle high variations in the angle of attack. The result? A glider that turns tighter and more efficiently than similar designs, perfect for low-level thermal flying

The properly-sized and removable V-tail is designed for control and great low-speed handling, crucial during soft thermals and the landing phase. And of course, the V-tail not only looks good but helps minimise the overall drag of the E-Medina for better L/D in all aspects of the flight envelope.

The fuselage is minimalistic, further minimising overall drag from the completed model. For more information see the [ArmSoar website](#).

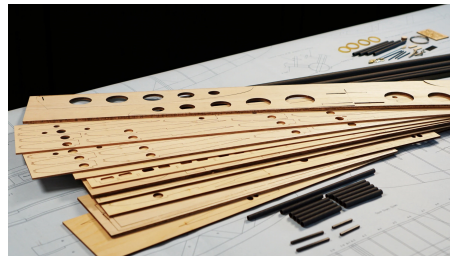

Click any image for detailed view. (credit: ArmSoar)

## Double Glider Backpack from REVOC Custom

Ready for a day scrabbling up the mountains and want to take *two* of your favourite gliders with you?

---





The Double Glider Backpack. (credit: REVOC Custom)

Then the new *Double Glider Backpack* from REVOC Custom is just what you need. On both sides of the bag there are pockets for transporting the fuselages. Thanks to the huge volume adjustment of these pockets, the model's fuselage always remains in place without the possibility of moving, no matter if it is a 'broomstick' fuselage or a massive model fuselage such as the MDM *Fox*, for example.

In the upper part of the bag, they have attached two fasteners with self-adhesive velcro fasteners, which allow for additional protection of the tail tip against moving during the march. You can choose for yourself which way of mounting the fuselage is better for your model.

The bag has been designed so that you can transport your models in a more convenient configuration: transport the models with the fins/elevators sticking out from the outside of the bag, or in a more compact style – with the fins/elevators hidden behind the bag. For more information see the [REVOC Custom website](#).







Click any image for detailed view. (credit: REVOC Custom)

**The Fine Print** All product descriptions in *Cool New Stuff* are prepared in collaboration with the product's manufacturer and/or distributor which is/are entirely responsible for ensuring the accuracy of their product's descriptive text and images contained herein.

*Would you like your product featured in Cool New Stuff? Please [contact us](#). Read the [next article](#) in this issue, return to the [previous article](#) in this issue or go to the [table of contents](#). A PDF version of this article, or the entire issue, is available [upon request](#).*

Unlisted

## RC Soaring in Türkiye



### **A snapshot of recreational flying activity at ‘the crossroads of Europe and Asia’.**

The Eskişehir Aviation Club (ESHAVK) has been active since 2004 (see *Resources*, below, for website.) There are model airplanes, gliders, hang gliding, ultralight, and paragliding pilots within the club, and it continues its activities in İnönü, Eskişehir city located in Türkiye. In the last 15 years, we have mainly been flying and pursuing our hobby with model gliders. The 2m glider models are the most popular among our club. To date, more than 20 of our modellers have participated in competitions with 2m model gliders.

### **EsGlide and EsMax**

Our club started to design its own gliders in 2012. In this project, builders have built composite (glass fibre, carbon fibre and kevlar) fuselages while others have opted for a simpler, wooden fuselage. Wood, composite, foam and hybrid wings were made, and many models were tested in competition. At the end of approximately five

versions, the *EsGlide* F3L 2m glider model, which complies with the FAI F3L provisional rules of 2022, will be able to be flown with carbon spar and D-box wooden wing versions. Numerous modellers have had the chance to build and fly dozens of *EsGlide* models since 2012.

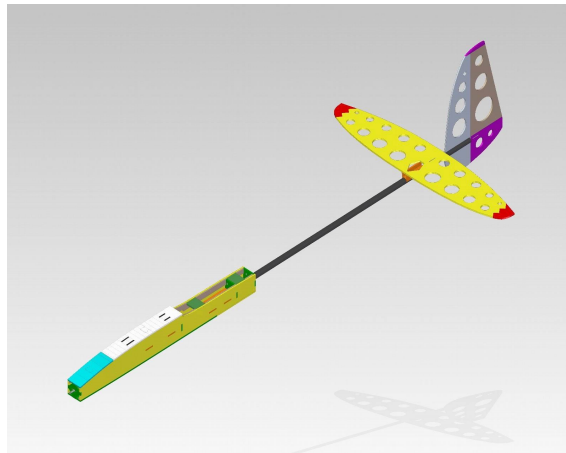

Left: The *EsGlide* during the design process. | Right: *EsGlide* 2m competition class glider with D-box wing and foam core wing as well as an *EsGlide* electro version, 2018.

In addition, our club designed an F5J model in 2018, and the prototype was built in 2019. Five of our *EsMax* models have been produced and flown to date. With a wingspan of 3.40 meters and a flight weight of 1200 grams, the *EsMax* is one of the lightest models in its class. There is no commercial production of our F3L 2m *EsGlide* and our F5J *EsMax* yet.



Left: EsMax F5J glider prototype under construction, 2019. | Centre: Completed EsMax F5J Glider (1200 grams flight weight), 2019. | Right: EsMax F5J during launch.

## 2m Model Glider Competitions

We started organising 2m glider competitions in Türkiye in 2002. We initially set out using an alternative to the F3J models. F3J models were costly and were fully composite. For this reason, modellers could not make their models and had to buy them ARF. Based on this idea, we decided to focus on the 2m class, which is primarily built with wooden materials and can fly with a two-channel receiver. These 2m models could cost one tenth of an F3J model.

---





The first 2m glider competition was held in Bursa, Orhangazi, in April 2005. After a few competitions, when the interest increased, it became clear that some rules had to be set. Model, competition area, flight rules, matrix and such like. All the issues were determined in many meetings, in consultation with community members from many cities, and shared with everyone. These rules are reviewed at the beginning of each season in a series of meetings.





From the beginning to the present, competitions have been held in 11 different locations in Türkiye including (number of events noted in brackets): İnönü, Eskişehir (11); Orhanli, İstanbul (10); Bekirpaşa, İzmit (4); Yalova Air Force Academy Facilities (7); Bursa (11); Riva, İstanbul (2); Büyükçekmece, İstanbul (2); Gölbaşı, Ankara (2); Orhangazi, Bursa



(1); Bandırma (5); Nicosia, Turkish Republic of Northern Cyprus (4). Through the end of 2021, 59 competitions were held in our country, and 283 competitors participated.

## Our Turkish Brand 2m Class RC Gliders

Models designed and built in Türkiye have helped modellers from 7 to 70 start in the sport and learn to fly. Some of these models are; *Albatross, Kamikaze, Miles, EsGlide, Turquoise, Star, Bures* and *Rookie*.

2m rudder-elevator-spoiler (RES) glider class rules have been published in the FAI provisional F3L category since 2022. In the new season, we plan to hold our competitions within the rules published by the FAI.



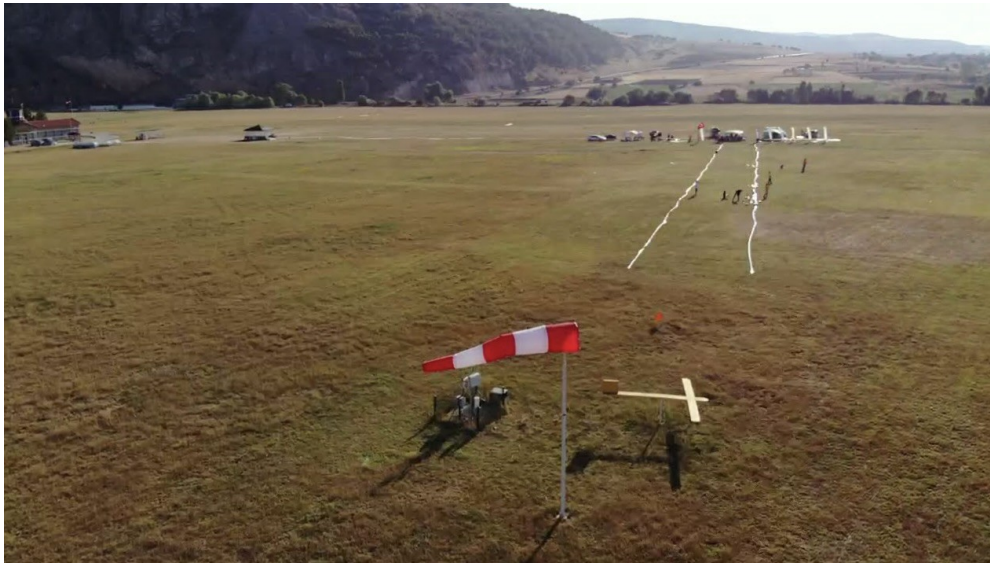

In this class, 11 competitions were organised by ESHAVK and held at the Turkish Aeronautical Association (THK) İnönü Aviation Training Center, one of the most famous airfields in Türkiye. While most of our competitions were attended by around 25 people, some were held with more than 60 pilots. Paragliding, glider, hang gliding, and model airplane training are given to Turkish youth at the İnönü Aviation Training Center, which became operational in 1936 under the auspices of the Turkish Aeronautical Association which in turn, was established in 1925.



The group photo for the ESHAVK 2m competition held at THK İnönü Airfield, Eskişehir, Türkiye.

On 3–4 September of 2022, ESHAVK will organise the F3L 2m glider competition in İnönü using the FAI rules. Why not join us! See our club

website in *Resources* below for more information.

## Special Thanks

We are grateful to our modellers who put great effort into the 2m glider branch. Thank you: Oktay Gülmez, Birol Öner, Mustafa Vehbi Koç, Philip Kolb, Kadir İstifçi, Mike Yust, Selim Etger, Eser Kışmir, Gültekin Kalay, Ufuk Özben, İlhan Gümüşel, Saim Gürer, Murat Yagan, Mustafa Kölemenoglu, Selim Nohutçu, Haka Oruz, Oykun İlgün, Yunus Karaer, Ataç Gültekin, Hayrettin Topel, Selçuk Gül, Savaş Zafer, Haluk Gülođlu, Murat Bozdemir, İlker Evrendilek, Mehmet Şekeciođlu, Mehmet Arslan, Ali Varış, friends from Istanbul, friends from Bursa, friends from Bandırma, friends from Yalova, friends from North Cyprus and last but not least the valuable staff of the Turkish Aeronautical Association. And another hearty 'thank you!' to you all.

## More Happy Moments from the Soaring Scene in Türkiye

















You can find our flight videos on our YouTube channel which is linked in *Resources*, below. Please don't forget to subscribe!

Thank you very much for reading and if you have any questions about RC gliding activities in Türkiye, please feel free to use the *Responses* section below and I will do my best to answer them.

Happy thermals and landings.

## The Slingsby King Kite



The Slingsby King Kite and its builder, Vincent de Bode. (credit: Raymond Esveltdt)

## Part II: More Empennage Design and Construction Details

*This is the second part of a six part series. Readers may want to preview [Part I](#), before proceeding with this article.*

### The Horizontal Stabiliser

I drew the stabiliser and rudder with *devWing* which I introduced in Part I. After some practice I managed to get some use out of it and convert the resulting files to DXF.

My friend Adri Brand was helpful by milling the ribs and now the stabiliser could be built. I wanted to keep that light as well; I chose 0.4mm plywood for the covering and web panels, combined with 2x2mm spruce spars, that should be strong enough.

I glued the hinges to the ribs before placing them on the building board. Then I glued the spars in place and also the web plates. To get

stability when removed from the building board, I filled the space between the two main spars of the elevator with balsa. In the nose, I temporarily glued diagonals and covered the top of the D-box with ply to form a kind of temporarily D-box. The lower ply can only be put on when the stabiliser is off the building board. The trailing edge is made of two layers of 0.4mm plywood with balsa in between. After removing the stabiliser from the building board, I cut the ribs to separate the elevator.

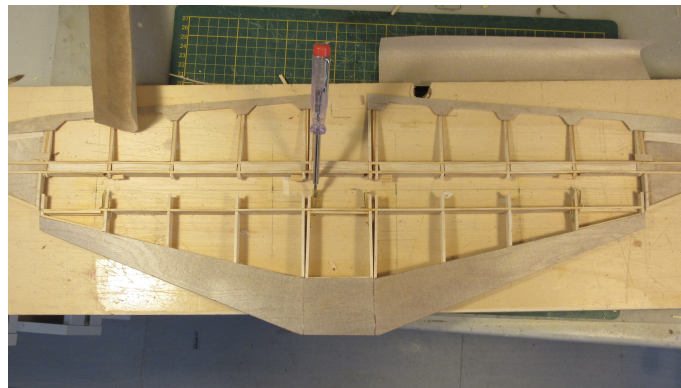
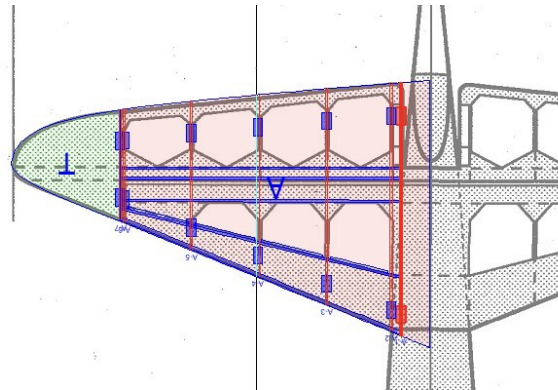

Left: devWing top view of stabiliser. | Right: Stabiliser roughly finished, elevator already cut loose.

The nose of the elevator was covered with a strip of pre-bent plywood, bent with boiling water. On these pre-bent ply strips, I marked the ribs on the inside to make the nose with the various gusset plates in one piece. In real life, the gusset plates were separate, but I wanted to keep it as light as possible. I glued these pre-bent strips with cyano over the main spar of the elevator, thus forming a torsionally rigid round nose.

---

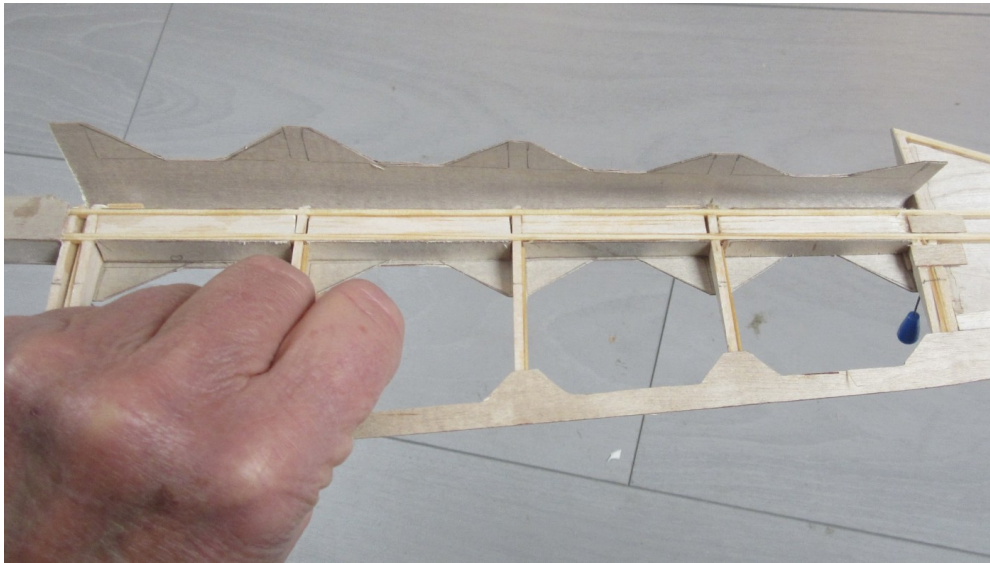

Nose of elevator halfway in the sheeting process.

At the location of the hinges, I milled openings in the ply nose of the elevator and now it had to fit to the fixed part. With some fiddling and measuring I succeeded. But later, when the the fixed part of the stabiliser was sheeted with ply, it turned out to be quite awkward to unlock the elevator hinges with a screwdriver to keep the spring-loaded hinge pins aside.

After some thinking I made a sort of angled screwdriver from 1mm iron strip, which I could fasten with a piece of tape. With a few of these iron strips, all the hinge pins were 'unlocked' and I could slide the rudder into place. To unlock I turned the iron strips a quarter of a turn back (at maximum deflection of the elevator) and the hinge pins sprang back. That worked nicely and I was very happy with this, because it could also be applied to the ailerons and make them removable for covering and varnishing.

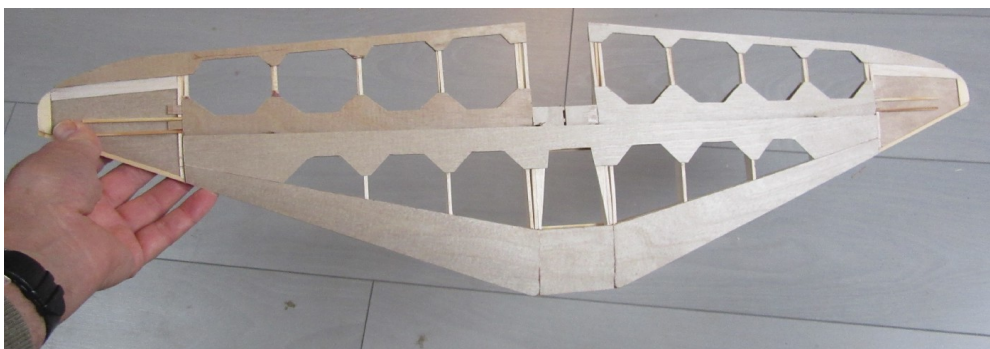

Stabiliser almost finished.



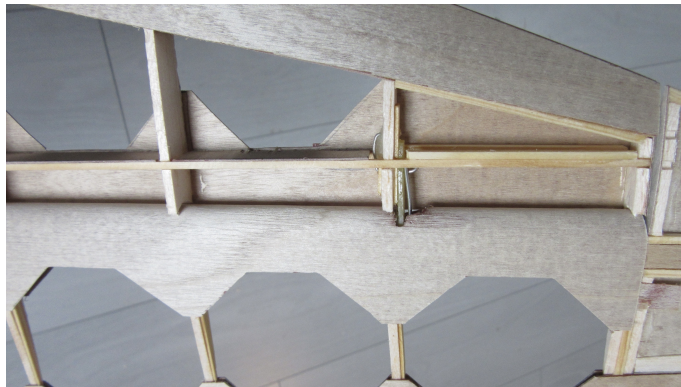
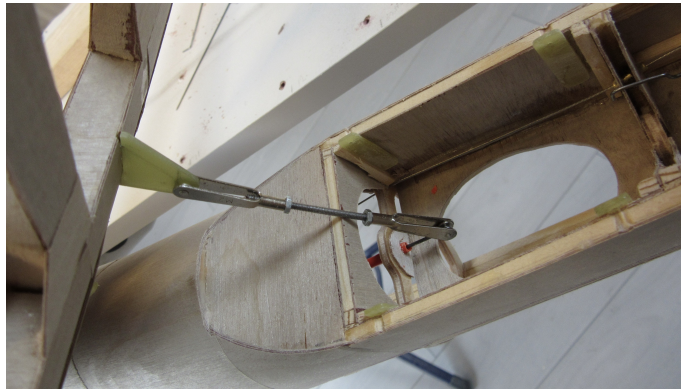

Left: stabiliser mounting strips and hinged control rod of the elevator. | Right: The hinge is in the 'locked' position. It will later be sheeted with ply.

## Attachment to The Fuselage

On the centre ribs of the stabiliser I glued four vertical epoxy strips with a 1mm hole that could slide over similar strips on the fuselage. Two long 1mm steel pins slide through them to secure it, almost the same as in the original. The mounting and dismounting of the elevator control was also a bit of a problem, you can't reach it. So I made a hinge point in the push/pull rod of the elevator, so that the metal clevis of the elevator could be easily disconnected and connected. When mounted, the hinge in the push/pull is straightened and becomes stiff. After this, I sanded all the triangular gusset plates neatly into shape and the stabiliser was ready to be covered. It weighs 118g, and feels very stiff.

## The Vertical Fin

After setting up the ribs, I made the top edge, laminated from 3x1mm spruce, which was bent after being poured over with boiling water and



then glued with thin CA.

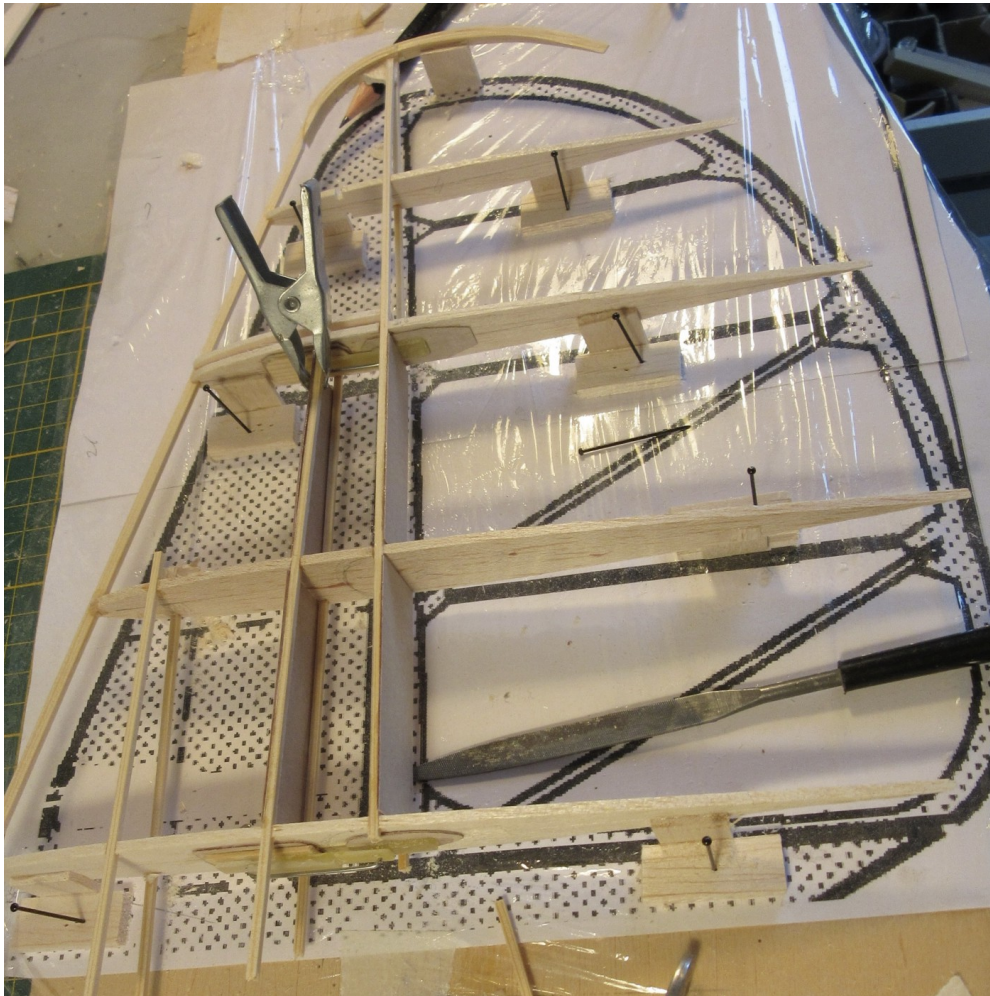

Fin with rudder setup.

The curved trailing edge was made from three parts of 0.4mm plywood glued together with some scarfed joints and then cut into shape. Between the ribs I glued pieces of 3mm balsa on top and sanded it in shape. On top of that I put a similar strip of 0.4mm plywood, forming a sandwich. Just as the horizontal stabiliser I cut the ribs at the hinges in two and now the rudder could be removed by sliding upwards. Handy for storage and transport. With a horizontal sliding steel wire at the bottom of the rudder it is locked. The fixed part of the fin is covered with 0.4 mm plywood, which, together with the main rudder spar, makes a light and stiff tube.

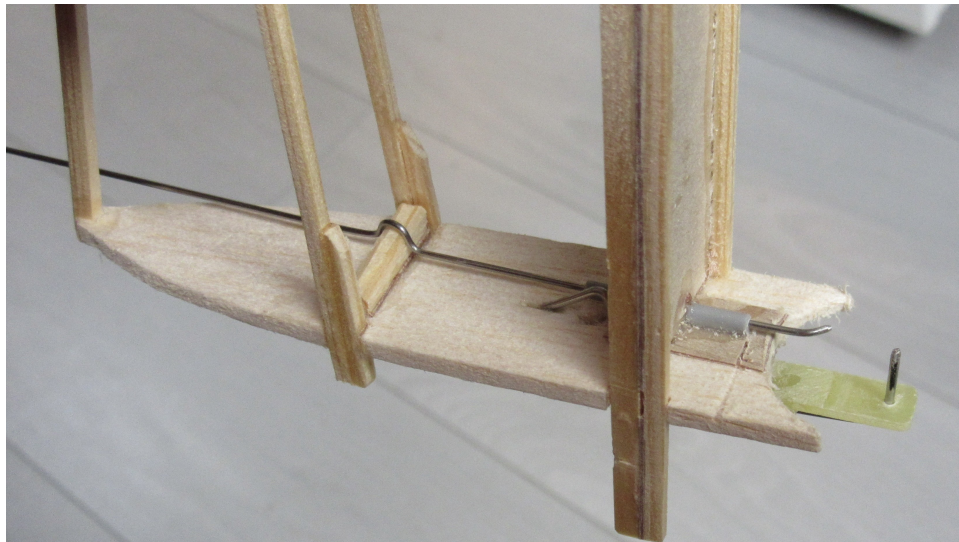

Left: Fin and rudder ready for sheeting. | Right: The horizontal 1mm steel wire locks the rudder – it can be slid in before the horizontal stabiliser is mounted.

Then I put capstrips on the ribs and sanded the gusset plates into shape. The rudder was now basically ready, and weighed 50g.

After finishing the tail planes it was time to digitally draw the fuselage. But we'll start that in Part III coming up in next month's issue of the *New RC Soaring Digest*. For now, thank you for reading and if you have any questions, please leave them in the *Responses* section below.

Until next time!

## My Slope Flying Sojourn in the UK



### Aviation nirvana awaits on 'this sceptred isle'.

As a slope flying enthusiast I regularly scour YouTube for inspiration. Movies of the most beautiful slope locations in the UK with some serious flying pass my screen. Now that we are going to tour the south of the UK with our motorhome I will have to take some gliders with me!

On the internet I already check where to find suitable locations. In my experience it's not always easy to find slopes by yourself that are easy to reach, with acceptable landing conditions and where you will not have an unhappy land owner. At Slope (see *Resources* below for this and other useful links) you can find many flying slopes, sometimes with info about parking or landing options. Slopehunter has more extensive information on a number of slopes. A spot that catches my attention is *The Wrecker*, a location in South Wales with several co-located slopes for different wind directions. It's at the Bwlch mountain – Welsh names can be quite exotic! – just south of the Brecon Beacons National Park which happens to be on our travel wish list. What a place! And driving to the *Wrecker* will hardly be a detour.



For the rest I will have to see how things go. When travelling with our motorhome we don't have a rigid schedule, the journey unfolds itself while on the move. As this will be mainly a family vacation I will not be slope hunting.

I could not find anywhere that the European A1/A3 certificates are recognised by the English authorities, so I obtained the English certificate (free) and registered as a drone operator for just £10. The requirements are more or less equal to the European requirements. Unfortunately paperwork is something to be dealt with in these times. But I'm legal now and good to go.

## The Motorhome

Our motorhome has a so-called 'garage', a huge storage space in the back for large luggage such as bikes. Next to our camping gear I can easily shove in some models. They are packed in a large model backpack that will serve me well if climbs by foot are necessary to reach a slope, and the backpack also provides good protection during transport. A packing checklist will prevent me from arriving at an amazing slope without transmitter, batteries or wing joiner. In the garage I have made a power point where I can connect my charger directly to the 12V household battery. This way I can always charge, even when the motorhome is not connected to 'shore power'.





Left: The backpack containing three models is in the garage of the camper, a Dream-Flight Ahi on top. | Right: later in the trip, assembling the AirOne on the lee side of my motorhome, at the Westbury White Horse Hill. (Click any photograph in this story for a larger version).

## Duxford

In the first week we visit the Imperial War Museum in Duxford, close to Cambridge. My son, pursuing 'aviation studies' at university in Amsterdam, shares my passion for aviation so he happily joins. Just after parking next to the museum a Hawker *Hurricane* starts its engine. The sound of a unique airplane is instantly recognised by he and I so straight away we bust off to the airport fence, leaving my baffled wife behind.



The museum has a large collection of airworthy aircraft and aircraft in



restoration.

While my wife has the motorhome to herself and takes care of the dog, my son and I enjoy the museum for several hours. Every aviation enthusiast should visit this museum, what an amazing collection of aircraft they have here! A tiny sample: U-2, SR-71, F-4 *Phantom*, *Concorde*, De Havilland *Comet*, B-17, B-29, B-52, Avro *Vulcan*, XB-70 *Valkyrie*, A-10 *Thunderbolt* and so much more. Furthermore the museum has a large fleet of aircraft that are airworthy or in the process of restoration.





The museum in Duxford has an amazing collection of aircraft.

During the day we see a *Hurricane*, *Spitfire* and *Texan* flying from Duxford airport. Eight halls of aviation candy, both military and civil.

## The Wrecker

After another day of museum (this time tanks) and a lovely day on the English countryside we drop our son at Bristol airport as he has to go back to school. My wife and I continue our English tour and head for Wales. *The Wrecker* is not too far from Bristol, so that will be our next destination. We arrive late in the afternoon and there's not too much wind, but off course I do investigate the spot. The slope is abandoned, nobody is flying. Facing the north is a straight steep slope where I can imagine some great lift in the right weather conditions. On the left the slope curves into a beautiful bowl that looks suitable for north to east winds. On the back side is a slope facing south. Just east of here there are two other slopes for westerly winds.

Today the wind is coming from the northeast, so the bowl and the north slope should be usable. The upper edge of the slope is quite sharp, creating a vicious rotor in windy conditions. This slope is called *The Wrecker* for a reason! According to the internet you can avoid the rotor by landing on a high spot on the other side of the road, so you will have to land your plane some distance away or cross the road with some coaching.



Flying 'The Wrecker'.

I assemble my RCRCM *Typhoon*, a sporty 2m glider. From the small parking lot along the road it's less than 100 meters walking until I'm halfway to the bowl. The edge is irregular and the slope very steep, so I do not dare to stand nearer than two meters from the edge. Despite the light wind there is smooth lift over a wide area. I don't gain much altitude, so the plane does not get overly fast, but with the stunning views it's a very enjoyable flight!





In this mild wind the rotor cannot be very strong, so I dare to land close behind me. With full butterfly I can make a nice steep approach and indeed the landing is without problems. I enjoy the view for a while, make another flight and then we have to start looking for a place to spend the night.

## Westbury White Horse Hill

Two days later I have some time left in the travel schedule, so I look for a slope between the Cotswolds and the New Forest and suitable for northwesterly winds. On the Slopehunter map I do find the Westbury White Horse Hill. Interesting name.

The last few miles to the slope are like many English countryside roads: very narrow, winding and steep. Our motorhome has to work hard, but should be used to that by now. I'm thinking: "Who wants to be in this desolate spot?", but on top of the hill we are surprised by a big parking lot with quite a few cars. And off course the ice cream cart you find on every tourist location here.







Today the choice is made to fly the *AirOne*, a motorized F3B glider with a huge speed range, ideal for mountain flying. I assemble the *AirOne* on the lee side of my motorhome as it's quite windy. From the parking lot to the slope is a level walk of just 200 meters. Being used to steep climbs in the French Vosges mountains this is so easy, a true 'walk in the park'. There are two slopes facing W and NW, joined together forming a sort of bowl. The wind is coming from WNW, so both slopes should create nice lift. The estimated wind speed is 15–20 mph, the air is hardly turbulent and flying is awesome. Today I can get more speed in my glider than on *The Wrecker*, so I can explore more of the flight envelope of my aircraft and do some aerobatics. There also seems to be some thermal activity.

The Westbury White Horse is one of many 'hill figures' found in the United Kingdom. Most of these figures are horses. They are made by cutting into a steep hillside and revealing the underlying geology, in this case chalk. The exact history of this particular horse is not exactly known. The original figure, a much smaller horse, was possibly to commemorate the Battle of Ethandun in the year 878. Only one drawing of this old horse figure is known. In 1778 the current horse figure, measuring 55 meters high and 52 meters wide, was drawn over the old horse.

In the Second World War the horse was turfed over to prevent German pilots to use it for navigational purposes. In 1957 it was covered with concrete to prevent further erosion of the chalk and ease of maintenance. The Westbury horse can be viewed from up to 17 miles in all directions.

On the NW slope, at the turning point to my right, there is the huge white horse on the slope face, quite a special sight. But also the view around is again amazing. The landing approach is a bit turbulent, but below five meters you get below the rotor and the air suddenly becomes smooth. I make a steep approach with some overspeed to cross the turbulent layer, the landing itself is butter-smooth. After

another two flights I am more than happy and pack the plane in the motorhome to continue our journey.

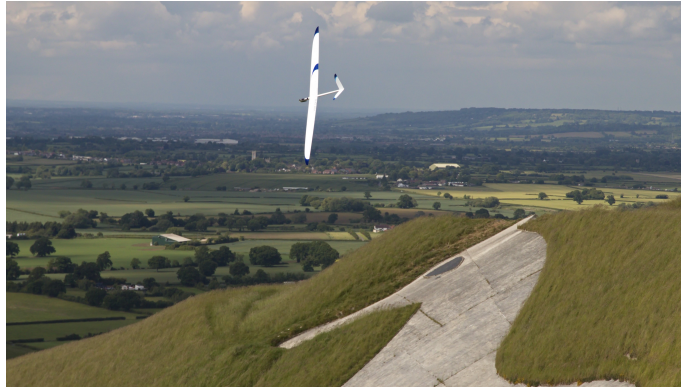

The last few days I make no more flights, but we do enjoy south England. The landscape is filled with hills (something we don't have in the Netherlands), there's a thousand shades of green, the pubs have good food and the people are friendly and helpful. I'm afraid this has not been my last trip to the UK. Next time I will surely bring my models again!

©2022

## Resources

- [Slople](#) – “Where do you want to fly today?”
- [Slopehunter](#) – “a guide to hills in England for soaring model gliders: what the slopes are like to fly at, what wind conditions they work in, how to find them...”
- [Imperial War Museum Duxford](#) – “Europe’s largest air museum. Walk through the same hangars and buildings as those who served at RAF Duxford...[g]et up close to over a century of aviation.”

- [Kevin Newton's Blog](#) – This RCSD regular contributor's excellent page with lots of information about flying *The Wrecker*.

## Rediscovering Martin Simons



Martin with the rebuilt and modified Skylark 2S at Dunstable, UK in 1987. Photo from the 'Slingsby Sailplanes', page 177.

### Part I: A short primer and thence to 'Slingsby Sailplanes'

*Through the good offices of the Vintage Glider Club – to which we offer our heartfelt thanks – the New RC Soaring Digest was put in touch with Margaret Simons, daughter of Martin Simons and a renowned journalist in her own right, based in Australia. It is with Ms. Simons' permission, on behalf of Martin and the rest of his family, that we re-publish selected passages of Martin's work. We are truly humbled and very thankful for the hard work and good graces of Ms. Simon in this regard. With that in hand, we are happy to turnover curation duties to frequent RCSD contributor Peter Scott who, in a multi-part series, will refresh memories many will have of Martin's work and for others, introduce his classic soaring-related volumes for the very first time. – Ed.*

My friend Keith Eldred recommended one of Martin's books to me. It was *Model Aircraft Aerodynamics*. I was very impressed by the depth



and breadth of the book and especially by Martin's clear writing style and superb drawings. His style is as brief as possible but without missing out any detail. He makes a point of including every possible relevant fact however minor. When you read a paragraph you know that you now know. All of that prompted me to look into his other writings. It might be that you already own, or have read, one or more of his books. Bear with me as there is always more to learn from his work.

But first, for those of you who are not familiar with Martin here is a brief biography from the covers of his books and his own website:

Martin Simons began gliding in 1947 and has been involved with the sport ever since. He has about 1,500 hours soaring time and is still active as a pilot. He has a strong interest in designing, building and flying model aircraft. He has had lifelong interests in education, philosophy, aeronautics, especially the sport of gliding, and has written extensively about these and other subjects.

He was born in Derbyshire, England, in 1930. After completing national service with the RAF he attended college and university in London while teaching full-time. He graduated with first-class honours in 1959 and subsequently became a university lecturer in London. In 1968 he emigrated to South Australia to teach at Adelaide University. He completed master's degrees in education and in philosophy. From 1970 to 1980 he edited *Australian Gliding*.

In 1954, he married Jean, and they have two daughters, Patricia and Margaret. After fifty happy years, Jean died of pancreatic cancer in 2005. Since then he has lived alone in suburban Melbourne but remains fully engaged with his writing and other activities. In recent years, while continuing to fly and write nonfiction, he has written three very unusual novels, *Jenny Rat*, *Cities at Sea*, and *The Glass Ship*.

Martin Simons wrote four print books about gliding, the first three of which are available to buy new:

- *Gliding with Radio Control*
- *Model Flight*
- *Model Aircraft Aerodynamics*
- *Slingsby Sailplanes*

I start with the last, Martin's book on the Slingsby company including the company itself, the first and last gliders it built and Fred Slingsby himself.

This book is no longer in print. Secondhand copies are available but it is a tribute to its quality that they are very expensive (see *Resources*, below). Gliding, both model and full-size, is an enthusiastic activity but has too small a market to justify a conventionally printed new edition. Maybe one of the on-line and on demand publishers might make it profitable?

I was impressed by the clarity and coverage of the book and the superb quality of the drawings. This book is a great source of images and information for the scale model builder. For many of the gliders there are constructional photographs and descriptions of the building methods. Anyone wanting material for the next scale model need look no further. Slingsby in the UK designed and built sailplanes starting with the simplest machines in the 1930's up to the glass ships of the 1970's. I have a blueprint plan of a *Vega* kindly sent to me years ago by Slingsby but have not yet built a model. Maybe a winter 2022/3 project?

You could blow up the excellent drawings in this book – with, of course, appropriate permission and acknowledgement – or redraw from scratch based on the drawings. The drawings have named aerofoils, dimensions and fuselage profiles. Exact aerofoil profile data could be downloaded from other sources using the name. The text contains the remaining data and all the other details that any committed scale modeller might need. In some cases there are photos of the gliders being built and of the cockpit interiors. The whole history of glider design can be seen in the succession of

drawings as profiles became smoother, materials change and aspect ratios steadily increased.

This is not a book to be read from front to back. Most of it is made of chapters each of which covers one of the glider models. It is a gem to dip into, make sure you are sitting comfortably when you start as you will find a lot of time has gone by before you know it.

All text that follows (between the grey horizontal bars) is directly quoted from Martin Simons' book.

---

## Slingsby Sailplanes

This book describes Slingsby sailplanes and gliders from the *British Falcon* of 1931 to the last motorless aircraft produced - the *Vega*. Each type is illustrated with an accurate full page, three-view drawing, with photographs and text outlining the background to the design. The drawings are based on the original workshop plans. Slingsby was for fifty years the main, and for most of the time only, producer of gliders and sailplanes in Britain. The company was one of the first to use glass fibre reinforced plastics in production aircraft as early as 1953 and were probably the first to use carbon fibre composite materials for main structural members. Many examples of their models are to be found all over the world.

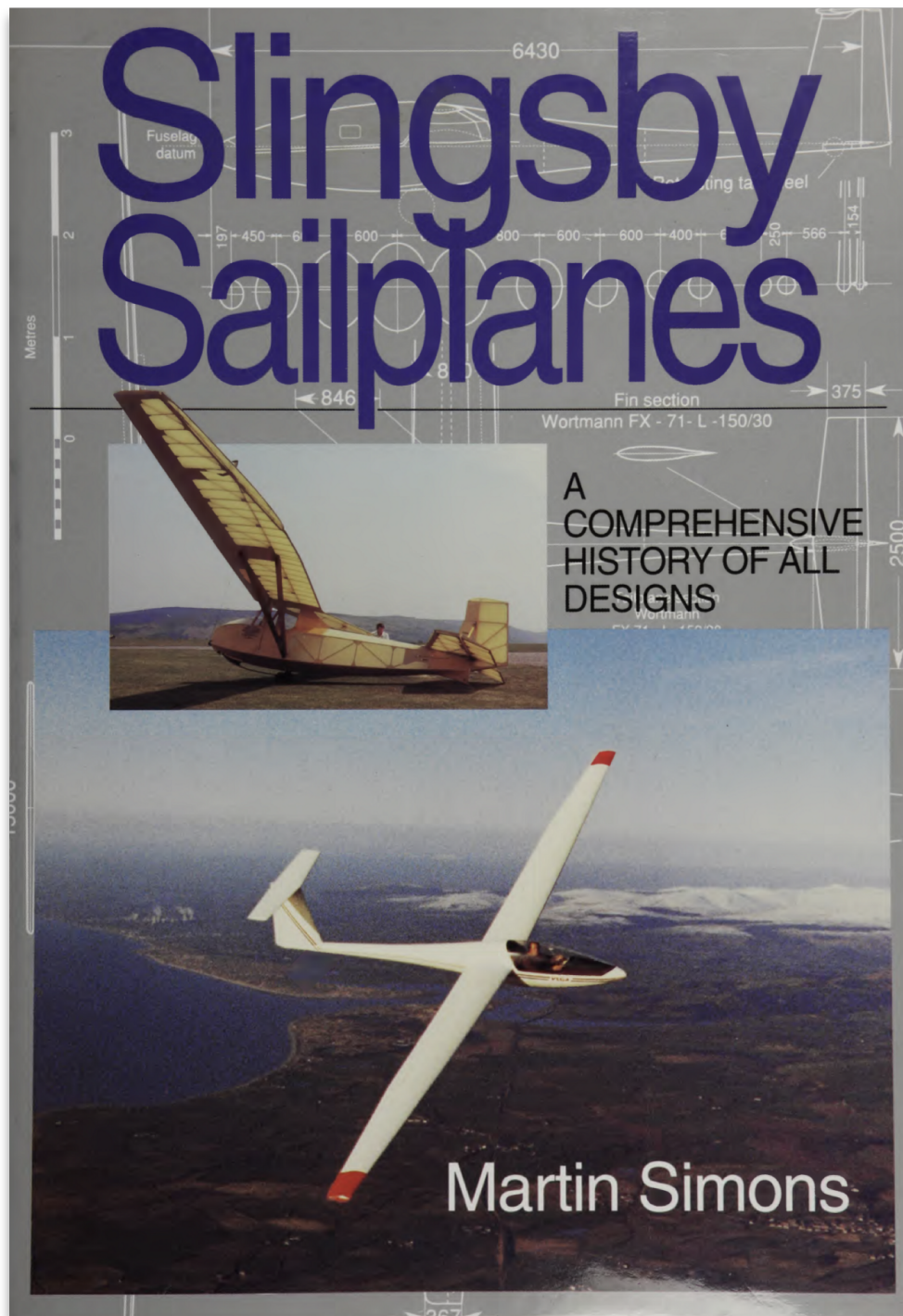

## Fred Slingsby

Frederick Nicholas Slingsby, born on 6 November 1894, had joined the Royal Flying Corps in 1914, and as a flight sergeant gunner/observer earned the Military Medal, when after his pilot had been killed in the air, he regained control and flew the aircraft back to the British side of the trenches. He remained in the service (by this time the Royal Air Force) until 1920, at which time he bought a partnership in a



woodworking and furniture factory in Queen Street, Scarborough, on the east coast of Yorkshire. Early in 1930 newspaper reports of the BGA's foundation were brought to his attention by a young dance band leader named Sanders who knew of Slingsby's service experience. With a few friends they founded the Scarborough Gliding Club in February.

The manager of the luxurious Royal Hotel joined and was elected chairman. Members came to meetings in the hotel wearing their best suits for a good meal beforehand. There were lectures and discussions. Flying operations began with a Dagling glider bought from the R. F Dagnall Company of Guildford, Surrey. They flew at weekends and on Wednesday afternoons, using sites at Flixton Hill, due south of the town, and at Sutton Bank, overlooking the Vale of York. Amy Johnson agreed to become president of the club. This, and the Scarborough Council's support, helped to attract members, especially after the spectacular but rather unsuccessful demonstration by Kronfeld and Magersuppe on Castle Hill above the town in July. Magersuppe's Professor sailplane was damaged when it hit a fence on take-off, and he came down in the sea to be rescued by a fishing boat. Despite this, he was appointed instructor to the gliding club at a salary of £10 per week. By the end of 1930 the club had 40 active flying members, and more than twice that number were paying small subscriptions to become social members and, doubtless, joining the festivities at the Royal Hotel.

Slingsby gained his A and B gliding certificates during the year, becoming the first Scarborough member and only the 30th person to do so according to the BGA register. The A certificate required a straight glide under control lasting 30sec. By the end of the year the club had trained six members to this standard. Sanders, the band leader, was not one of them. The B Certificate required a flight of 1min and two further flights with safely executed right- and left-hand turns with good landings. Three of the six Scarborough members achieved this. (The training methods used are described in the chapter on Slingsby's Type 3 Primary.) The Dagling was broken regularly, and

Slingsby, the club's ground engineer, found himself and his factory constantly involved in repairs. He was forced to present bills for materials and working hours spent away from his business. Thus he entered the gliding industry as an ancillary to his regular occupation. He had a sound background in aircraft woodwork and rigging, and was an excellent draughtsman. The factory provided tools and machinery. His workmen, he said, began to prefer working on the glider to furniture making. Slingsby had no formal qualifications in aeronautics or engineering but was ready to employ qualified consultants. He had a shrewd business sense and a great enthusiasm for gliding.



The replica Falcon, showing details of the cabane struts, skid and bracing wire. (M. Simons)

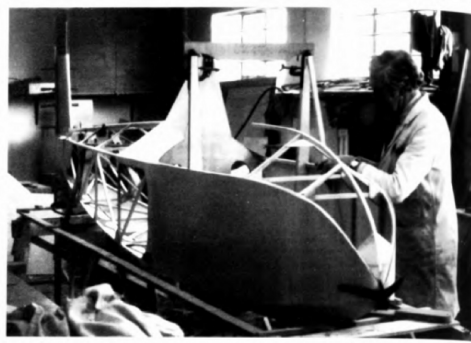

Building the modern replica of the British Falcon at Southdown Air Services. (K. Frupp)

The British Falcon built in recent times, finished in clear dope and varnish like the original. (E. A. Hull)

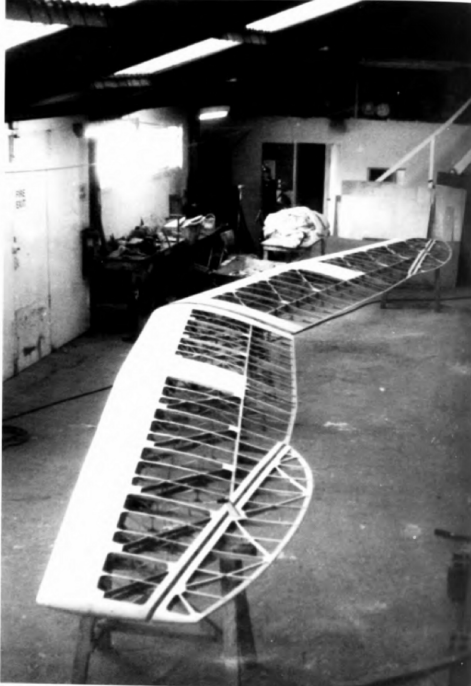
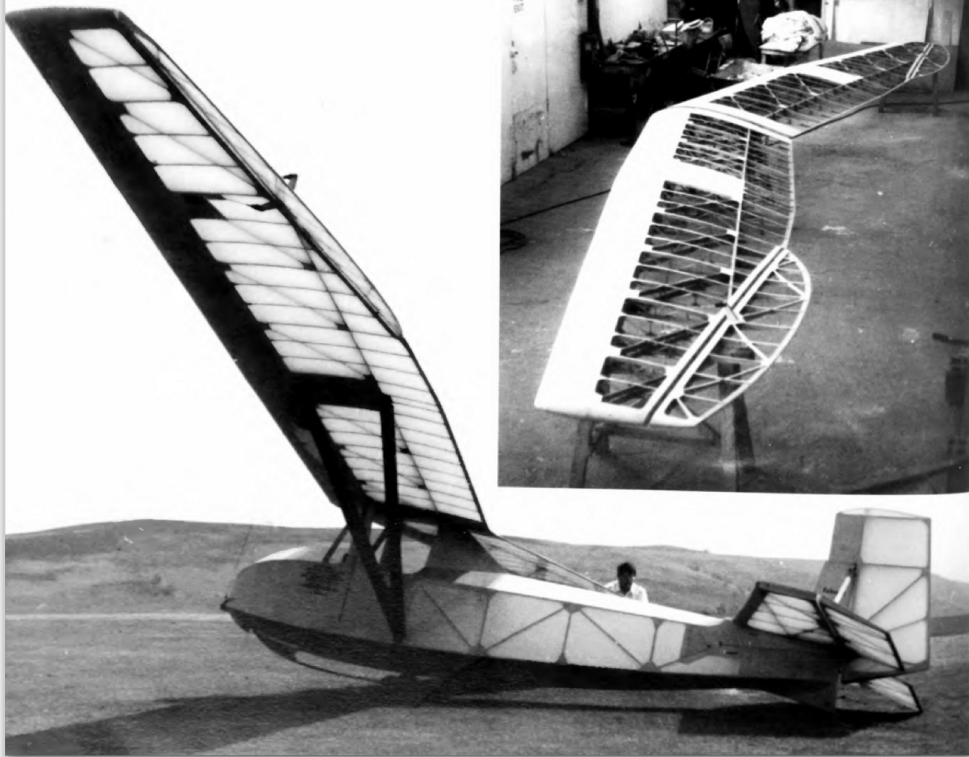

From 'Slingsby Sailplanes' as it appeared on page 16.

## Slingsby Gliders

Full sets of working plans for almost all Slingsby aircraft before 1950 were discovered in 1969 by Norman Ellison in the lofts above the offices. They were saved from destruction, and after a long period in storage are now preserved by the Vintage Glider Club. The drawings by the author in this book are based on these originals and on other

plans of later types from the company's archives, rather than on previously published outlines or extracts from brochures.

Fred Slingsby first built gliders at his furniture works in Scarborough, but as the business grew and demanded more space he moved for a while into the abandoned tram sheds belonging to the town corporation. A transfer to Kirbymoorside on the northern edge of the Vale of Pickering was made in 1934. (For some reason the town is now spelled Kirkbymoorside on maps and road signs, but to gliding people it will probably always be without the second 'k'.) In 1939 a new factory was built at Ings Lane, south of the village, where it still remains. There were several changes of ownership, and a period of closure when the company was in receivership during 1969. The works reopened later in the same year. Glider design and production at Kirbymoorside then continued until 1982. The modern company, Slingsby Aircraft Ltd, is exclusively concerned with powered aeroplane manufacture.



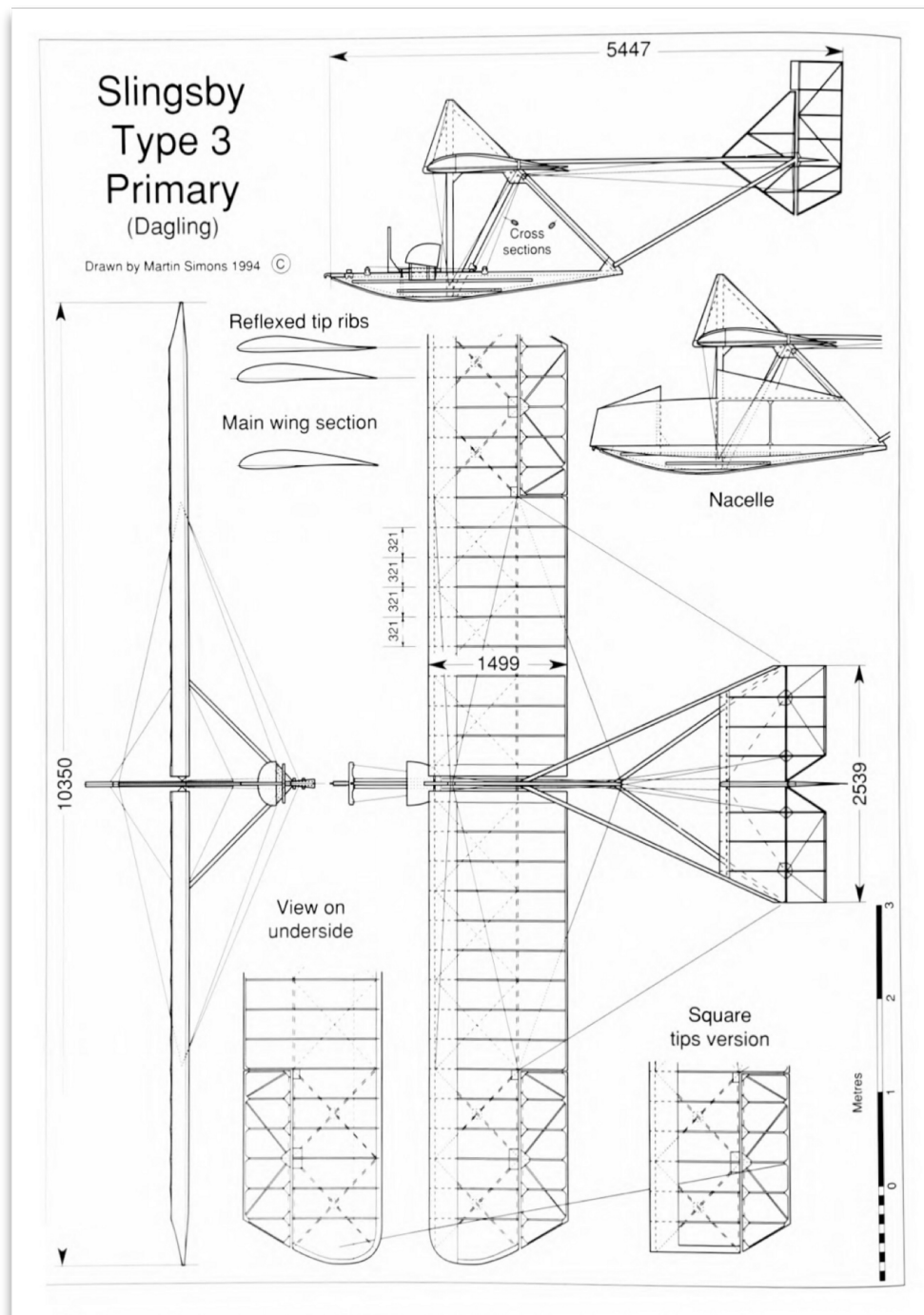

From 'Slingsby Sailplanes' as it appeared on page 18.

## The Origins of a Sport

Before their first powered aeroplane flights, the Wright brothers made many trials with gliders, and on about a dozen occasions achieved soaring flights of more than a minute's duration. The longest of the four famous powered flights on 17 December 1903 was still of less than 60 seconds endurance and another year passed before they exceeded this time. In 1911 Orville Wright returned to Kill Devil Hills,

North Carolina, with a glider. On 23 October he made a soaring flight of 9 min and 45 sec. Many years afterwards he was asked why he went back to gliding after eight years. His 'official' explanation was that some serious testing of a new control system was to be done, but this was only part of the reason. At the age of 68, Orville admitted that he found soaring to be more fun than flying with an engine. A new sport had been discovered.

The first gliding competition also had a serious purpose. The Versailles Treaty of 1919, ending the First World War, banned aeroplanes in Germany. Many pilots, aircraft manufacturers and students of aeronautics saw a bleak future for German aviation, but gliders were not specifically mentioned in the prohibition. Wolfgang Klemperer and his younger friend Erich Meyer, who had experimented with hang gliders in Dresden before the war, saw the loophole. Early in 1920, in an article in the magazine *Flugsport*, they suggested that a glider competition should be held in the Rhon mountains of the Fulda district. The dome-like Wasserkuppe, swampy in places and at that time covered by unfenced pastures, had been successfully used for gliding during several pre-war summers by a group of schoolboys from Darmstadt.

Oscar Ursinus, editor of *Flugsport*, supported the idea of the competition with enthusiasm and agreed to take on the organisation. Under his guidance the twomonth-long meeting from mid-July into September was modestly successful despite a fatal accident. Klemperer himself, recently appointed to an academic post in the Aerodynamics Institute of Aachen Technical College, made the best flight in the *Schwarzer Teufel (Black Devil)*, a cantilever monoplane glider which he had designed and built with his students in the Institute. From the beginning, sailplane development in Germany was closely associated with such student flying groups, the *Akafliegs*.

The Rhon contests became annual sporting events, continuing even after the lifting of the ban on powered flight in 1925. A full-time gliding school was established on the Wasserkuppe, and another at

Rossitten on the sand dunes of the Baltic coast. Extended slope soaring flights of several hours were achieved in 1922, and thermal upcurrents were discovered in 1925 and used systematically from 1928. Cross-country flights of more than 150 km had been achieved by 1930. Sailplane and glider building factories, notably those of Alexander Schleicher at Poppenhausen near the Wasserkuppe, Edmund Schneider at Grunau in Silesia and Gerhard Fieseler at Kassel, were established.

Apart from a brief flurry and one lively meeting at Itford Hill in 1922, very little interest was shown in Britain until the news of the German successes filtered through to the pages of *The Aeroplane* magazine. The British Gliding Association (BGA) was formed late in 1929, and visits by prominent German experts were arranged. In February 1930 Professor Georgii lectured to the Royal Aeronautical Society on soaring meteorology, and Fritz Stamer, who was running the training school on the Wasserkuppe, described the methods used there. The BGA issued its first gliding certificates in March that year. Most influential of all, Robert Kronfeld brought his beautiful Wien sailplane and toured the country, performing a famous slope-soaring cross-country flight from Itford Hill to Bedworth near Portsmouth on 17 June. Carli Magersuppe, sponsored by the *Daily Express* newspaper, joined the tour with a Professor sailplane.

There was an upsurge of enthusiasm. More than 90 gliding clubs were formed all over Britain, and some aero clubs established gliding sections. 3 Fifty clubs responded to a questionnaire distributed at the end of 1930. Every club had at least one glider or was in the process of building one; some possessed two or three. The total active involvement in gliding approached 2,000 persons. The largest group was the London Gliding Club, not yet settled at Dunstable, with 112 members, three club gliders and four privately owned machines.



“A Slingsby Type 3 primary glider in flight in 1940. It was recognised that cadet pilots could be trained on gliders and the RAF investigated. This led eventually to the Air Training Corps gliding programme” as it appeared on page 24 of ‘Slingsby Sailplanes’.

---

Next month I delve deeper into the ‘origin of the species’: Slingsby’s Type 1 *Falcon* (*Falke*). Thanks very much for reading.



## How Many Degrees in a (GPS) Triangle?



My lovely Sonoran Laser Art 'Yellow Jacket 3.5M' and trusty Multiplex 'EasyGlider 4'.

### Part I: Yes, Iain, it is all your fault.

There I was, just flying along, and I got the tell tail wing bump of a nice thermal. I let the plane continue around to see if I can find her again. Sure enough the plane starts climbing as I try to core it. Pretty standard right? The difference here is I was flying an E-flite *Apprentice* electric trainer. After a few years away from RC, I thought I would give powered planes a try since that is what my local club flies. My personality is such that when I decide to do something I go all in and so I did with four electric planes including a EDF soon inhabiting my basement. Sadly, it was not to be, when I found myself thermal hunting with my *Apprentice*, I had to accept the fact that I am a diehard glider guider.

So, what I am hoping to share with you is my path to GPS Triangle Racing. Most of the articles I have read are from the lucky folks that have completed the journey. I have not, so this will be a learning experience for both of us. If you do not know what GPS Triangle

Racing is, I have links to a couple of excellent New RCSD articles and a very informative YouTube video in the *Resources* section below. Basically, the point of this task is to fly your glider – which is equipped with a GPS sending telemetry to the ground – around a predefined triangle course as many times as possible in the allotted time. There are multiple classes and a well-defined but still evolving set of rules. This event has been popular in Europe for a while and is rising in popularity here in the US with events across the country. There's a national event held in what looks like an awesome place to fly, Montague, California.

This is shaping up to be a longish journey, so you might as well get to know me a bit. My path to modelling is normal for a flyer my age (59). I started with the Guillows rubber models that never flew well, then many years of flying 1/2A control line. Around 1976 I saw planes plying in a field right across from my house in Reston, Virginia and immediately investigated. Guys were flying the most beautiful planes I have ever seen. I remember *Windfrees* and a Hobie *Hawk* along with the other gliders of the era. My failing memory seems to remember Skip Schow letting me fly his plane, but I may just be putting a local legend in my memory bank. Anyway, since I loved flying so much I went into the Navy and volunteered for submarines. Go figure. My super understanding wife put up with me spending what little disposable income we had crashing planes all over the country for the next 14 years. I got out and ended up in New Mexico where I flew with the Albuquerque Soaring guys. Super group. I got into Thermal Duration competition and participated in the famous Hiss & Boink events run by the late great Buzz Averill. Since 1999 I have lived in Southern Maryland where I flown off and on and have settled on electric sailplanes as my destiny.



1996 picture of my daughter and high-start retriever Laurel in Los Alamos, New Mexico. Remember when we had to skin the wings? Bonus points for identifying the plane.

I have an urge to compete in just about everything I do. I don't need to do especially well, I just like testing myself against others. So when I decided to jump back into sailplanes with both feet I knew that I would like to work my way into competitions. My first thought was F5J, since to me they are the thoroughbreds of the sailplane world,



but after watching some videos I realized that even though I am a pretty good flyer, I do not have the mad skills that the good F5J pilots have. So, I pivoted to ALES, which though requiring awesome skills seems a bit less stressful. I did my research and ended up with a beautiful *Yellow Jacket 3.5M RES* kit from Sonoran Laser Art that was a joy to build and set-up. I also ended up with a *Medina 2M ARF RES* ship from ArmSoar. Again, see *Resources* for links to both.



This a very large box. But why? Miata and UMX 'Radian' for scale.

Well, while I was working towards this ALES thing I discovered GPS Triangle Racing in the previously mentioned New RCSD article. It sounded cool, so I started poking around and just fell in love with the whole concept. I have had a ham radio license since 1985 – I got it so I could fly RC using the 6m band. Remember those days? – and love tinkering with electronics. The big planes with lots of data coming into the ground station made me drool. I am still having fun getting the ALES planes flying and currently there are many more ALES competitions than chances to fly GPS Triangle against others, but GPS Triangle is where I am headed.

Next time, I'll let you know what GPS Triangle plane I ended up with and most importantly, the surprises I have encountered.



---

## Landing On!



The 'Zugvogel' looking innocent at White Sheet!

## (not landing out)

*This article originally appeared in the August, 2018 issue of the legacy RC Soaring Digest. We reprise it here with higher resolution photos (click any picture a larger version) as well as live links to Chris's videos – Ed.*

It will not have escaped the notice of those who sometimes pay attention to the outside world, that we live in changing times. One of the things that I have noticed in recent years is the changing of once reliable weather patterns. Now, unlike most of their powered counterparts, scale sailplanes have the luxury of being operated at two completely different venues: either from the slope, or from the flat via aerotow. The latter has not really been too affected by the changing weather, but in my part of the world (the county of Dorset in Southern England) the once slope-friendly winds have become surly and uncooperative, vindictively blowing in all the directions that are of no use to us at all.

---



Left: Where it all started: two 'Dusters', 1/7th- and 1/5th-scale. | Right: Smallpiece gives the Dart 17R a professional launch.

There is a reason that many of us, if forced to declare a preference between aerotow and slope flying, would prefer to fly our scale models from the slope (hoping all the while that no tug pilots were listening). The reason is this: operating from the hill allows for repeated close-proximity flying, thus enabling the pilot to appreciate and enjoy the fruits of his or her labour, and as a side benefit, listen to the satisfying sounds of an airframe politely asking the air to move aside. (What about the beautiful scenery, I hear you ask? Yes, that too.)

---



Left: The 'Dart' in action in glider mode. | Right: A scenic shot of the 'Dart' at a Wessex Soaring Association site.

So, given that slope opportunities have become few and far between, what about those days when the wind is on the slope, but light, and it would take a brave soul to launch off, faced with the possibility of landing out rather than landing on?

I should point out that landing out, especially to those of advancing years, is not a prospect to be contemplated lightly. By the time you have staggered to the bottom of the hill, the knees will have turned to rubber. Now you have to negotiate wild shrubbery, a barbed wire fence, an ocean of stinging nettles, and the task of finding your



beloved model in a dense field of corn or barley: not a deed that will garner approval from the hard-working farmer. Having found your model, its time for the journey to be reversed, with the addition of a large, awkward, and puzzlingly twice-as-heavy glider.



Left: 'Bergfalke 4' launch: self-launching at this size is reasonably practical. |  
Right: Too low at White Sheet: time to throttle up!

Now your ancient lungs will be put to the test, as your legs seem to become a year older with every step and you start to sound like a steam engine with a secret sorrow. At least, you say to yourself, I can count on my pals for sympathy and support, just as howls of derision reach your ears from the safety of the top of the hill.

As you can see, the pleasures and perils of flying in such conditions can be balanced one way or the other, so what if pleasure could win the day?

---





Left: 'Zugvogel' launch: it's often safer to launch a large model powered up. |  
Right: Another light air evening session with the 'Topaze'.

When I was ejected from the world of work into retirement some seven years ago, one of the items on my bucket list was to find out what all the fuss concerning electric flight was about. Coincidentally, my own slope soaring club, the WSRFC, was trialling the use of electric assist (e-assist) models for use on the slope. (White Sheet Radio Flying Club. The word Radio tells how old this institution is!)

Firing up the PC, I set to designing a couple of small versions of the BJ1 *Duster*, each with a moustache on the front end. Encouraged by the result, I then went off at a tangent and designed a couple of different sized versions of the Kaiser K11 motorglider. Before I could stop myself, a quarter scale Fournier RF5 appeared, but none of this was really tackling the original question. Then, a moment of epiphany: my pal Motley Crew did the unthinkable: he electrified one of the huge Phoenix K8's that were all the rage at the time. (This was when they

were starting to fall out of the sky. Motley stripped his, added some proper wing spars, thus coining the phrase 'Certificate of Mottification')



Left: Motley gives the 'Javelot' a manly launch. | Right: 'Super Javelot': you can go back on approach as far as you like, knowing you'll make it back.

We found ourselves, late one summer afternoon, on the edge of the hallowed SW bowl of White Sheet Hill with said model. The wind was on, but somewhat lacking on oomph, sometimes going off for a well earned rest. An invisible message passed between myself and the third member of our little gang, Barrington V. Smallpiece: he gasped and grabbed his ankle, I grabbed the transmitter, and the Herculean task of launching the monster was left to Motley. Once in the air, a short burst of power saw the K8 safely above the horizon and the fun started. Given the conditions, the usual howl of the wind in the earholes was notably absent, and as the big model aviated by us in a series of low passes, we heard the siren song of the airstream being

gently modulated by those tiny control movements so necessary to flight, and as she whispered by, it almost seemed as if the model was alive. It was an electric moment (pun not intended) and the die was cast – I wanted some of that!



Left: The business end of the Javelot with the blanking plate fitted. | Right: Power train layout in the 'Super Javelot'.

Back home, the excitement still buzzing (darn it, another pun!) I cast around through my design back-catalogue, looking for inspiration. It came in the form of the 3.5 scale Slingsby *Dart*, surely a contender? Using the Turnigy G60 to turn the prop, the *Dart* was an immediate winner, displaying all the visual and sonic themes of the K8, but at a much more manageable size. Faster than you can blink, along came an e-assist version of my *Bergfalke 4*, also a winner. You'd think I would be satisfied now, wouldn't you, but the scale policeman that lives in the head of all scale modellers started getting nasty, pointing out that the *Dart* and the *Bergfalke's* face furniture was definitely not



scale, and even removing the propeller couldn't make it so. Luckily, Smallpiece, a retired engineer, came up with a plan, and I set about putting it into practice on the next design, the *Scheibe Zugvogel*.

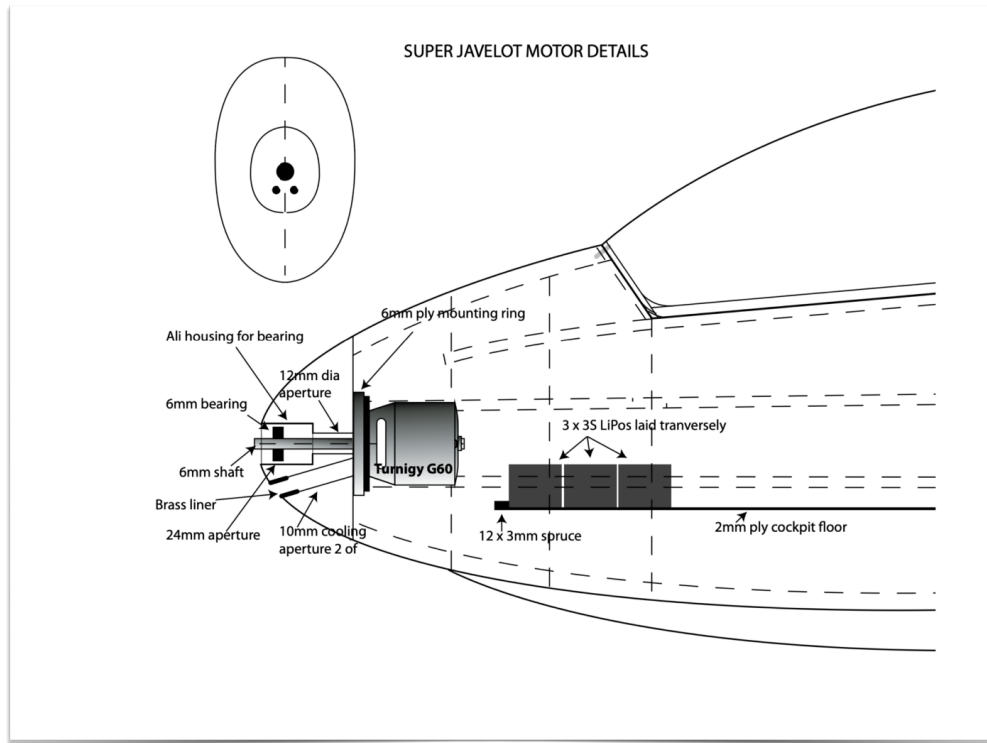

This is how it works: all my gliders have a solid nose block, made up from several applications of car body filler. A suitable hole is drilled through the nose into the fuselage bulkhead, followed by two further holes lower down to allow the ingress of cooling air. The motor is handed to, who removes the original drive shaft, and inserts a longer one, facing the other way. He also supplies a bearing to support it at the front, and an aluminium housing to support the bearing. The housing is inset in the nose in order to swallow most of the propeller gubbins, leaving the prop flush with the nose, all nice and neat. Now for the *pièce de résistance*: with the prop removed, a blanking plate is made up to fit over the prop shaft, the length of which finishes flush with the nose. Voila! Only a close inspection will show that something un-scale lurks inside, and when the wind blows, the model reverts to being a glider ordinaire. So excited by this anesthetising of the scale policeman in my head, two more models quickly followed, the WA 22 *Super Javelot* and *Scheibe LC10 Topaze*.





Also where it started: Motley's mighty e-assist K8.

Smallpiece's genius knows no bounds: he also came up with the all-aluminium-sideways-tow-release, thus allowing e-assist gliders to be aerotowed as well, and therefore overcoming the problem of all the ironmongery at the front end getting in the way of a conventional release. (I wonder if the release will now cost 25% more with all the tariffs' flying about? Can you believe it? Another pun!)



"operating from the hill allows for repeated close-proximity flying"

Let me set forth a scenario for you. Imagine two scale soarers launching in quick succession off the hillside, one with e-assist and one without. The wind is on the slope, but is fitful and full of lethargy. At first the lift is good and allows both models to get above that all-time regulator of good and bad, the horizon. Then, reality bites, and both models start sinking. My stance is one of relaxation, the other guy has started to stiffen and breathe a little more heavily. Never mind, the lift will pick up again in a minute or two, won't it? Both models sink lower. If I was the other guy, I would have plonked my model down by now, somewhere, any where, but he's an optimist. Time to bail out: I open the throttle. With the motor set up I currently use, even full throttle produces only a pleasant low hum, unlikely to annoy even the most ardent e-assist critic. A six second burst sees the model some 200 feet above the horizon, and settling down once again to glide mode. The sun is getting low, we're in the middle of nowhere, the only sounds are gentle lowing of the cattle, the hum of insects, and the ancient sound of the *Sailplane Song*, a whispering atmospheric melody in C major. A quick loop, and the key changes to a higher pitch as the glider whistles around like a leaky kettle. One more burst of power sees her set up for a landing, the airbrakes adding some zest to the orchestra, and the ghostly overture ends as the wheel gently touches the grass.





Full circle: Author's (then) current project, 1:3.5 scale BJ1 'Duster' for e-assist.

As I sit there afterwards, draining the remains of the coffee flask, I ruminate that if this was heaven, it would be well worth praying for. I hear a gasping, wheezing sound as the other guy finally makes it back to the top. I know him well, it's the me of Christmas Past, but I am older and wiser now, right?



Left: Author self-launches the 1/4-scale 'E-Bergfalke'. | Right: Having used the last of the lift, it's time for the 'Bergfalke' to come home.

## Update

Since this article was originally penned, it must have come to the attention of the Weather Gods that I was having way too much fun and they decided that enough was enough. Now, we hardly ever get one of those days when a light wind blows gently on to a nearby hill

and the e-assist gliders whisper up to a safe altitude. Instead, we get industrial quantities of breeze, and only the F3F guys get any fun.



The Topaze in glider mode.

### Wassmer WA-22 Super Javelot Specs

<b>Scale</b>	1:3.25
<b>Span</b>	4.6m
<b>Weight</b>	9kg (20lb)
<b>Wing Section</b>	HQ35/14 (centre) — 12 (tip)
<b>Motor</b>	Turnigy G60 Brushless Outrunner 500kv
<b>ESC</b>	Turnigy Brushless ESC 85A with 5A SBEC
<b>Prop</b>	14/8 folding
<b>Battery</b>	2 x 3s 2200 Lipos

## Tailpiece

Don't just take my word for the foregoing: it's all been recorded for posterity and uploaded to YouTube and the links can be found in *Resources* below. Thanks for reading!



---

## Soaring the Sky Podcast



(credit: Mitch Thomson)

### E076: Mountains, Mishaps and Milestones

*This is our third instalment of this ongoing series where we select and present episodes from Chuck Fulton's highly-regarded soaring podcast. We have linked all of the services where you can find Soaring the Sky, or simply click the green play button below to start listening to this month's selection . – Ed.*

Our guest pilot today, Mitch Thomson, started his soaring journey 15 years ago picking up RC gliders after years of flying powered RC planes and building scale airplane models. He realized quickly that he wanted to scale up from RC into his own glider when the opportunity presented itself. Soaring in his own glider was something he put on his bucket list for over a decade, and culminated in an orientation flight at Warner Springs California back in 2018 where his first flight took him up into winter wave and so much altitude that he and his instructor in the backseat got to do some fun aerobatic maneuvers on the way back to the field. At that point he was hooked.

After they landed, he signed up on the FAA website for his student certificate and then started a rigorous training regimen at the Soaring Academy, finally taking his glider solo flight in October, 2019. After a COVID virus delay in the Spring of this year, he took his checkride and got his glider private certificate in May. Mitch is now soaring out of Crystal Airport, Charlie November 46 on the Los Angeles Sectional, located in the high desert of Southern California just northeast of Los Angeles, and is enjoying his days flying his ASG29 in the San Gabriel mountains. Today he will share some interesting stories about his learning journey, mountain soaring, and a couple of mishaps and learning experiences that happened along the way!

For our *Safety Soaring* segment today we are joined by aerobatic pilot and world champion Luca Bertossio from Italy. For our *Soaring Tips and Technics* segment today we are joined by Czech Republic National Gliding Team member Barbora Moravcová.

©2020

## Resources

- [Soaring the Sky](#) – From the website: “an aviation podcast all about the adventures of flying sailplanes. Join host Chuck Fulton as he talks with other aviators around the globe. You never know who the next guest will be on *Soaring the Sky*.” You can also find the show on [Instagram](#), [Facebook](#) and [Twitter](#).

Subscribe to the *Soaring the Sky* podcast on these preferred distribution services:

## Electricity for Model Flyers



(credit: Aloft Hobbies)

### Part IX: Telemetry

It's a bit like buying a dishwasher. Whenever someone says to me that he or she is thinking of doing so for the first time I always say, "only buy one if you are sure you will always be able to afford, or find room for one. There is nothing worse than being forced to do without one again." It's the same with telemetry. Once you have used it you will never want to be without it. If you have never used it you won't understand what the fuss is all about. After all, who minds drying up? Well, my hand shot up (dropping the wet cup in the usual tactical way). This article is about telemetry in general but FrSky in particular.

When I restarted flying about six years ago I bought a Spektrum DX6 because it was a make I had heard of. Then I read a series of articles in the UK magazine *Radio Control Models and Electronics* about OpenTx and FrSky (pronounced 'free-sky'). I wanted flaps on a new glider, but the DX6 only had switched additional channels and I wanted a rotary or slider control. The FrSky *Taranis* has two of each.

So the DX6 was put on a shelf and it's still there. Any offers? I soon learned how open and flexible the *Taranis* was and got to like Amber's voice. But the biggest leap was telemetry. At modest cost and weight FrSky allows you to read altitude, climb rate, GPS position, ground speed, air speed, motor current, motor RPM, receiver and battery voltages, ESC and other temperatures, liquid fuel consumed, mAh used and signal level received at the receiver. Yes, all of that. Sensors mostly weigh only a few grams and cost from £10 for the LiPo voltage sensors to about £45 for the airspeed indicators.

Other makes will have some, or even all, of the sensors. Having read here what FrSky can do, you can then compare and contrast the others for size and cost. FrSky has a big range of transmitters but I think the X9D offers the best value for money and is very flexible. If you are thinking of buying one you can read my free downloadable PDF manual from my website (see *Resources*, below).

The telemetry sensors run on a bus system similar to S.BUS rather than needing a hub like other makes. They connect in a daisy chain, connecting one to the next and so on, using female to female servo-type leads that finish in a single SmartPort port on the receiver (Rx). Note that I use 'female' here in the correct electronics meaning of metal sockets not metal pins in the connectors. An example is in Picture 1. Some suppliers describe these as 'male- to-male'.



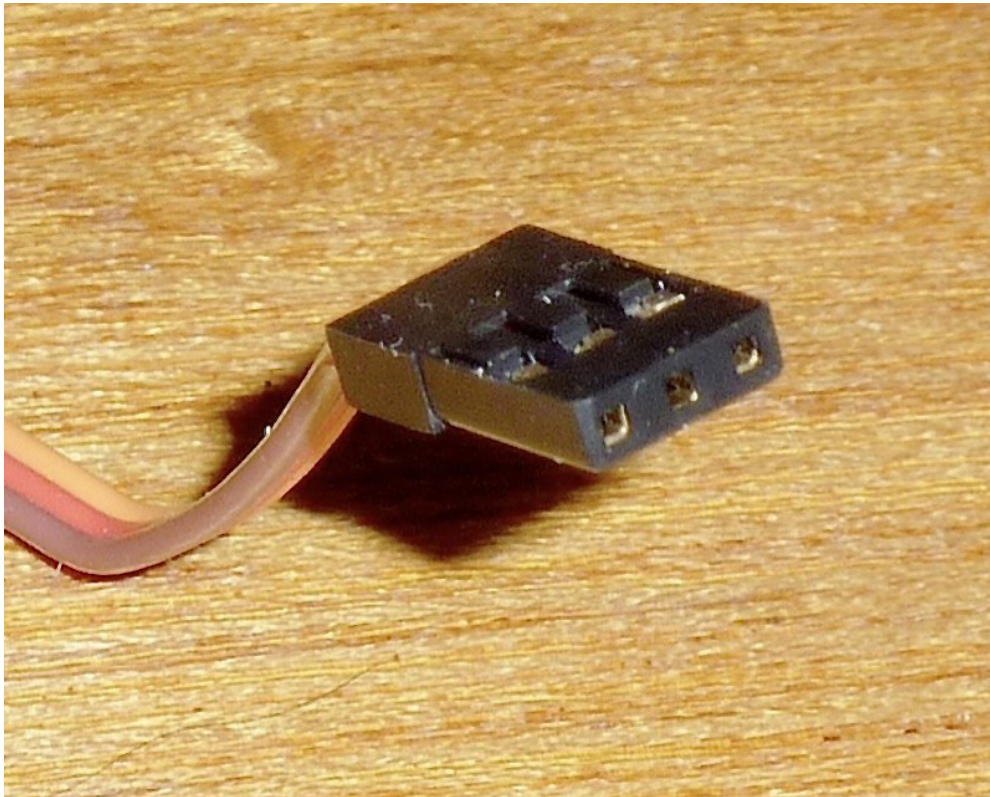

Picture 1: Female servo connector.

## OpenTx Telemetry

OpenTx is the operating system that FrSky uses on the *Taranis*. It is open source so is written by volunteers and is free. The more I learn about it the more impressed I am. Setting up telemetry and designing the display screens is simple and as you learn more you can make wider use of the great strength, accuracy, reliability and flexibility of the system. To help with the hardware costs of the FrSky project I send a modest annual donation.

Confusingly the same name 'sensor' is used for both the real physical devices and the data they produce.

## Real/Physical Sensors (electronics)

These are the actual electronic devices. Each has two IDs. The first is an ID for the device and has four digits, e.g. F210. This is unique and can't be changed. The second is the ID used by the Rx to identify the sensor, with a value between 1 and 32. This must be unique within a

model setup. The default values can be changed. You might never need to do this, but if for example you want to monitor the RPM and temperature of two motors and ESCs in one model the second sensor must have a different ID. Physical sensors produce one or more data. The system calls each datum a 'virtual sensor'.

## Virtual Sensors (data)

For clarity I will use the words 'datum/data' rather than the term 'virtual sensor(s)'. Each datum can be reset individually using a special function and a real or logical switch, or you reset all at the same time using a Tx function. There are two types:

### Data Produced by the Real Sensors – 'Custom' Data

Each datum has a name, unit and value. These can be changed using the `Edit` function (more below). One datum can be displayed more than once, for example to display height in both metres and feet, or cubits if you are really traditional.

### 'Calculated' Data

Amongst other things, data can be added, averaged or multiplied, and the minimum or maximum of up to four data can be found. To do this you click `Add a new sensor`. This opens an edit screen. You give the data a name then set `Type` to `Calculated`. For example the battery's voltage multiplied by the motor current gives the power. Don't forget the calculated data are still called 'virtual sensors'. Editing is described later.

## Using Data

You can see data on one of the four telemetry screens, hear it read out to you at chosen intervals or use it as a logical switch to trigger an action – a function. You could even use it as an input, for example to change elevator trim settings depending on airspeed or to open an air intake to cool an overheating motor or ESC.

# Editing a Real or Virtual Sensor

1. Move to the screen that lists the telemetry sensors.
2. Select the sensor to edit or create a new one.
3. Long press on `ENT` and select `Edit`.
4. Type: Choose `Custom` or `Calculated` and click `ENT`.

This is the list of things you can edit: If `Custom` is selected:

- `Name` – Change it if more than one of the same sensor.
- `Type` – Reads `Custom`.
- `ID` – First is fixed. Don't change the second if already sensed unless it's a duplicate.
- `Unit` – Use this to select, for example, m or ft for height.
- `Precision` – Sets the number of decimal places. Useful for when value is read out by Amber.
- `Ratio` – Multiplier to use to get the correct reading, e.g. for a voltage checked by voltmeter.
- `Offset` – Sets initial value to non-zero, e.g. for `GAlt` when airfield not at sea level.
- `Positive` – Ignores negative values, e.g. no vario sound when sinking.
- `Persist` – This tells the transmitter to retain the value from previous sessions, e.g. Aspd+ would give maximum ever airspeed for that model.
- `Logs` – This tells the transmitter to store the data stream on your memory card.

If `Calculated` is selected some are different:

- `Type` – Reads `Calculated`.
- `Formula` – Choose from `Add`, `Average`, `Min`, `Max`, `Multiply`, `Totalize`, `Cell`, `Consumpt`, `Distance`. (more details below)
- `Source1` to `4` – The lists will contain all of the data items currently in telemetry.

- **Filter** – Averaging smooths values that change a lot, e.g. LiPo voltage.
- **Auto Offset** – This sets the first received value as the zero when reset or at switch-on.

## Formulae Explained

- **Add**, **Average**, **Min**, **Max** and **Multiply** are obvious.
- **Totalize** – This adds the sensor value to running total.
- **Cell** – The value of an individual cell is found using: **Cell Index** – number showing position in cell series; **Lowest** – obvious; **Highest** – obvious; **Delta** – highest minus lowest voltage.
- **Consumpt** – mAh used using current sensor data.
- **Distance** – Distance between the pilot and the model using GPS.

## Telemetry Sensors with Default IDs and Data Items

Sensor	ID	Data items
Air speed indicators (2 models)	10	Aspd
Current sensors (2 models)	3	VPAS (40A only), Curr
Liquid fuel monitoring	22	Temp 1 & 2, RPM, Volume remaining, Flow rate, Max flow, Average flow
GPS	4	GPS, Galt, Gspd, Hdg, Date, Time
Lipo voltage sensors (3 models)	2	Cells
RPM and temperatures	5	RPM, Tmp1, Tmp2 (see note below)
Receiver	25	RSSI, RxBt, SWR

Plus a sensor hub with sockets for even more compact sensors for: Fuel Gauge, GPS, Variometer, LiPo Voltage, Temperature, Power Supply, RPM Sensor, Triaxial Accelerometer. For an RPM sensor you must set up the number of coil pairs on the sensor edit screen.

## SP2UARTs

SP2UART (universal asynchronous receiver/transmitter) devices are like modems. You need a pair, one in the Rx and the other connected to a read/write device. They can transmit and receive analogue and



RS232 serial data at up to 9600 baud (that takes you back a bit doesn't it?) but usually at no more than 300 baud. Yes 300 bit/s. I could imagine it being used in robotics but I can't yet see a use in model aircraft. The data they produce are called A3 to A6.

## Telemetry Screen Design

The FrSky *Taranis* allows four different telemetry screens each of which is blank until you fill it with your required data. Screen design is very easy. You move to the screen design page and first decide whether you want the screen to contain numbers or bar displays. With numbers (Pictures 2 and 3) you step to each of the nine positions and select the datum you want for that position from a list. On the bars screen you can only select three data (Picture 4), in this case just one.

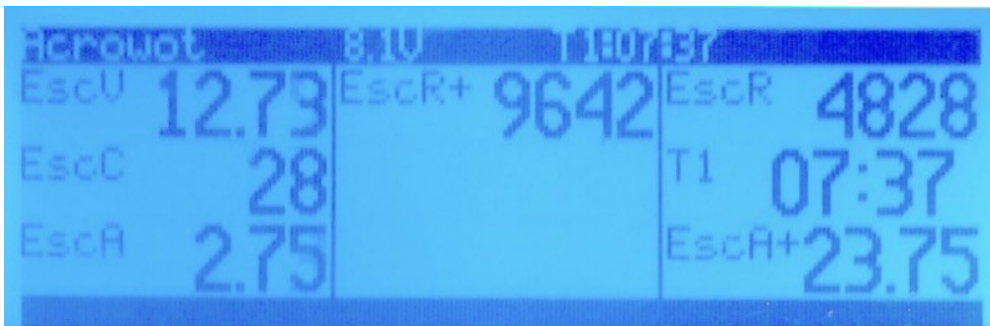

Picture 2

In Picture 2 you can see that I have throttled up to 9642 RPM where the current was 2.75 A. Then back to low with a current of 2.75 A and RPM 4828. In playing about to take this picture I have used 28 mAh of the 2200 so the LiPo still has 12.73 V. Remember that the + means the maximum for that flight. The weird names for the data are because here I am using a FrSky *Neuron* ESC about which more later.



Picture 3

Picture 3 is the screen for a simple glider not using a *Neuron*. The LiPo voltage in this case comes from a separate sensor. The altitude data comes from a vario zeroed on my living room floor. **RSSI** means received signal strength indication, which is the signal seen by the receiver. This makes range checking very easy. **100** means full signal.

For completeness here is the alternative bars screen.



Picture 4

## Standard Telemetry Screen Design

As you see from above, up to now I have used different screens for different models. That can be confusing, so I decided to adopt a standard screen layout. This was my first draft:

<b>For live flight data:</b>	<b>Live flight data</b>	<b>Flight record</b>	<b>Ground test</b>
<b>Plus voice message when a critical level reached and no EscC available</b>	Battery voltage EscV	Maximum rpm EscR+	Rpm EscR
<b>Plus voice message when at 30% mAh</b>	mAh used EscC	Maximum current EscA+	Current EscA
<b>Plus voice message every 10 seconds</b>	Altitude Alt	Maximum power Watt+	Power Watt

I fly Mode 2 so it is safer to move my left hand to read the live flight data if I have to. They are in any case read out to me. Where a datum is not available such as altitude on an aerobatic power model the box will be left blank.

## Telemetry Voice Messages

Glancing down at a screen when flying can be risky – less so for gliders than aerobatic models. Mostly I set up the Tx to speak the key data for me. Once the battery has reached about 30% charge I have the mAh used read out. For flying on a field with a height restriction I have altitude above ground level spoken every ten seconds, though I could get the message read out only when I reach 122 m. If I land and the voice says something like ‘minus two metres’ I know that atmospheric pressure is rising and the weather next day might again be good for flying.

## FrSky Neuron ESC

FrSky sells a range of clever electronic speed controllers for 3S to 6S batteries. Called *Neuron* they come in 40, 60 and 80 capacities with 50% more momentary current. They have a voltage adjustable 7A SBEC. The reason I mention them here is that they have built-in telemetry sensors for voltage, current, RPM, power consumption and temperature which plug into the receiver SmartPort. They are compact with good finned heat sinks. There is much more about these devices below.

The ESC comes packed in foam in a solid plastic box. It is very strongly made with a thick aluminium plate top and bottom. All sides are open. There are two servo-style ports to connect to the receiver – one for the throttle/BEC lead (PWM) and the other for the telemetry Smartport (S.Port). You need leads with both ends female, and must cut the red core on the PWM lead if using a separate receiver battery, but this is a separate lead so you are not cutting one that is permanently connected to the ESC. All versions are the same size and weight, though different prices, and can be connected to 3S to 6S batteries.

After soldering on XT90 and 4mm sleeved bullet connectors, the *Neuron 60* device weighed 73g. This is exactly the same as a Turnigy

*Plush* 60A, though of course the latter has no telemetry. The sizes are:

- *Neuron*: 60 x 33 x 16mm
- *Plush*: 72 x 30 x 17mm

So the *Neuron* is just a bit shorter. Other ESCs are available.

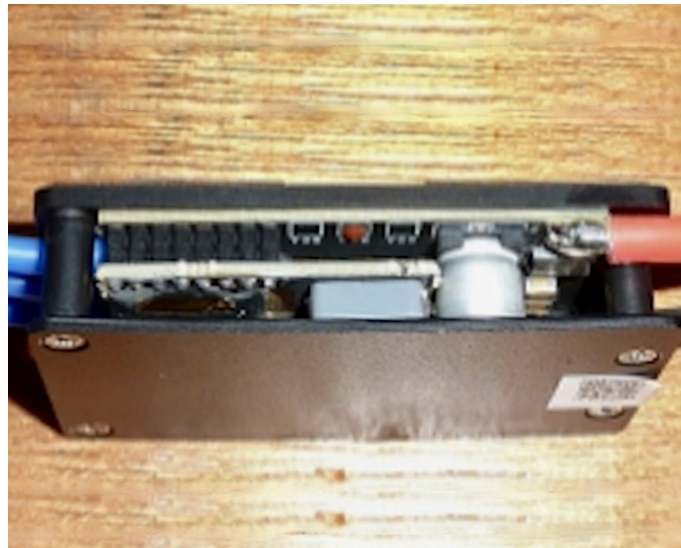

Left: Picture 5 | Right: Picture 6

I tested the telemetry using a *Taranis* X9D plus transmitter running OpenTx V2.2.2 and an X8R receiver. Initially no motor was connected, so the current, RPM and mAh consumption data were zero. I allowed the ESC to power up the receiver through the BEC and the voltage shown in RxBt was 4.9V. Using a voltmeter I checked whether this was the voltage sent by the BEC and it was, so the BEC appears to default to 5V. It can provide 7A. The voltage can be changed.



After using `Discover new sensors` on the *Taranis* all of the data appeared as follows:

Names	Values during test.		
OE50	2560804	This stores encrypted BEC values whatever that means.	
EscV	16.71V	Lipo voltage	Volt
EscA	0.00A	Motor current	Amp
EscR	0rpm	Motor speed	RPM
EscC	0mAh	Consumpt – mAh used	mAh
EscT	44°C	ESC temperature	Temp

## Neuron S Versions

In late 2019 FrSky issued updated versions of the *Neurons*, designated 'S' (for small?) and I bought a 60S and a 40S. They are very much smaller as you can see from Pictures 7 and 8, which compare the 60 and the 60S. FrSky has done an amazing job squeezing the speed control circuitry and the telemetry into such a small device. The S has a jumper to select whether the BEC is used so you don't need to cut the red core on the throttle lead. One last bonus was that the throttle did not need calibrating. It presumably defaults to 1000 to 2000 ms.



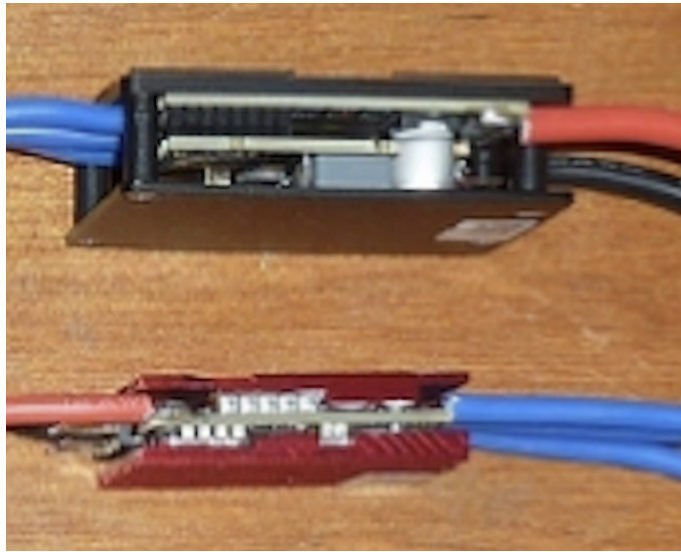

Picture 7 | Picture 8

Weight and dimensions of the 60 are 76g and 60 x 33 x 16mm. In the case of the 60S, they are 47g and 45 x 22 x 12mm. In both cases weights are with one XT90 and three bullet connectors.

I installed a 40S in my *Acro Wot* foamy. It fitted perfectly in the original position. I now don't need to connect the battery balance lead to a voltage sensor for voltage telemetry so the wiring is much neater. And now I know when I've used 1500 of the 2200 mAh in the battery 'cos Amber tells me. I used the default 5V BEC on the 40S.

I fitted the 60S in my *Wot 4*. It was much smaller and lighter than the Turnigy *Plush* ESC I was using so I was able to put it in a more convenient place, which left room for a NiMH receiver battery and switch.

As always, in both cases the telemetry data was found by the *Taranis* without a problem.

## Choosing a Propellor

This is an area where the *Neurons* excel. Using RPM, power and current you can experiment with different props until you get the optimum size for maximum safe power and current for a given battery.

I now use *Neurons* as standard in all of my new models. All I then need in the gliders is a variometer. I could of course buy a FrSky receiver with a vario in it, but I prefer to stick to good old RX8R ones and FrSky varios weight next to nothing. Ain't technology wonderful?

## **A Word of Warning**

I have found that the S versions of *Neurons* are more fragile electronically. If you misconnect one it is likely to burst into flames so check very carefully before powering up.

Next month it's on to light emitting diodes and resistors .Thanks for reading, and if you have any questions, please do not hesitate to get in touch.

©2022

## Club in Focus



Ann Tekatch holding her magnificent 3.2M Ava Pro. Ann has been a member of SOGGI for almost thirty years!

## Southern Ontario Glider Group Inc. (SOGGI)

We're an RC soaring-oriented charter club of the Model Aeronautics Association of Canada (see *Resources below*) located in the vicinity of Hamilton, Ontario, Canada. SOGGI was first formed in 1975 and became incorporated in 1983.

The club has two flying locations. One being a slope soaring site located about 30 minutes from the city, used with permission from the local conservation authority. The thermal flying sites are sod farms that the club is graciously allowed to use by a local sod company. Due to the nature of the sod farming business, the location of the thermal flying fields changes about every two years.





Left: Rob Nelson launching his 72" wingspan, Skeeter off of our slope soaring site in Westover, Ontario. | Right: Terry Kovack launching his 1.5M DLG off the slope at Westover, Ontario.

SOGGI is a small 'grass roots' club with typically 30 to 35 members from all walks of life, including a few private and commercial pilots. Members fly models ranging from the 1970s era to current kit-built and moulded sailplanes. There are a number of avid scratch builder members with decades of model building experience. Some members also fly aerotow with a sister club and there are also several avid free flight modellers.







Left: The author holding his 4M Explorer. I have yet to maiden this beast! | Right: Terry Kovack holding his brand new 2M Toy slope soarer.

Depending on the Spring and Fall weather, the flying season may run from April to November and, weather permitting, the flying sites are available every day during daylight hours. SOGGI typically holds 8–10 events over the season with a mix of fun flies and thermal duration style contests, alternating between line launch and motorized sailplanes.





Left: Mike Sherlaw, ready to launch his electrified, 3.5M Grafas Maxi! | Right: Tim Glover line launching his classic 108" wingspan, Oly II while our club's Chief Flight Instructor, Terry Kovack observes.

The season tends to wind down significantly in October and November due to the lack of good flying conditions. Indoor meetings are held monthly during the off season that include workshops and other activities related to the hobby. A number of members also keep active flying indoors with members of another local RC club.







Left: Tim Glover proudly displaying his lovely old line launching classic, a 2M Gentle Lady! | Right: A 2M Sophisticated Lady owned by the author. On of my favourite line launchers!

SOGGI is a very friendly, socially active RC club that is always looking to welcome new members! You can check out the website (see *Resources*, below) to learn more about the club.

©2022

## Tiny Offset Screwdriver



**When you need to MacGyver yourself out of a tight spot.**

Here's a tool I use quite a bit. It's great for getting at those screws that you can't reach with a regular screwdriver. Most common offset screwdrivers are way too large.



I have a long one for getting to the screws that hold servos in, a short one for the servo arm screw and a very short one for tight small

servos. Saves taking the servo out, when all I need to do is move the arm a notch or two. Even with servo frames, it lets the servo stay in position when moving the arm.



Just take one of those many Allen wrenches you have laying around and grind the tip. You need to taper the sides so it fits into Phillips head screws.

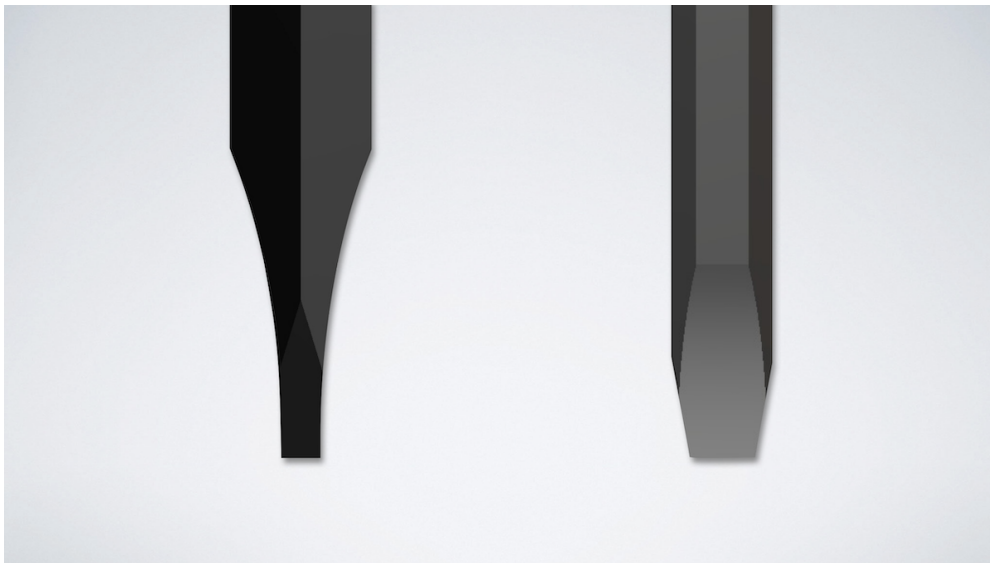

Left: Side view grind. | Right: Front view taper.



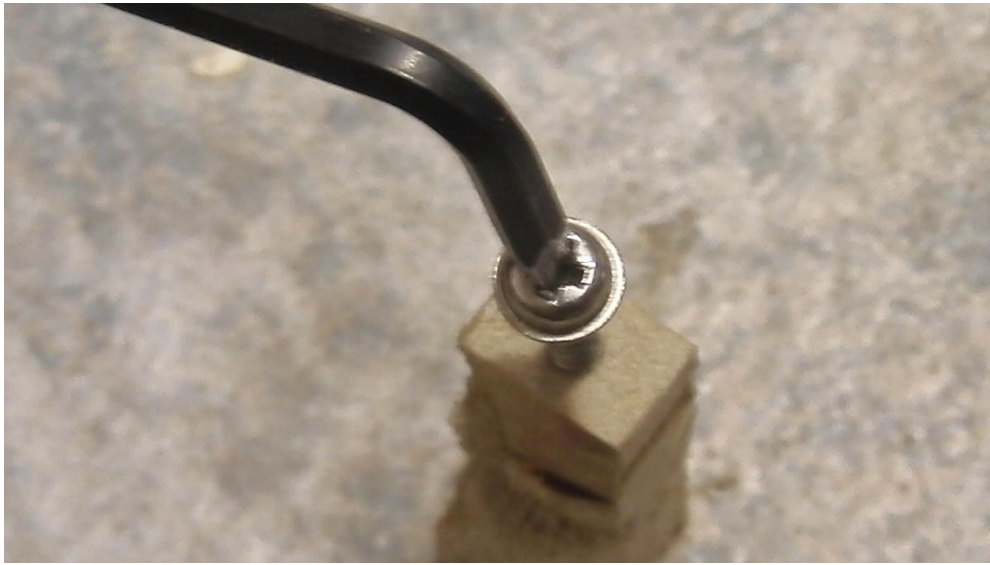

I have both 90° and 30°. Sometimes I can only move the driver a tiny bit, but with the two angles I can pretty much get any screw out.



If you have an idea for something, but don't have the tools to make it, and it's something I can use in *Tom's Tips*, I'll consider making it for you and credit you with the idea. However, if published, it will be considered in the public domain.

Thank you for your reading and good luck with your project!

©2022



## The Saga of the Sperry Special

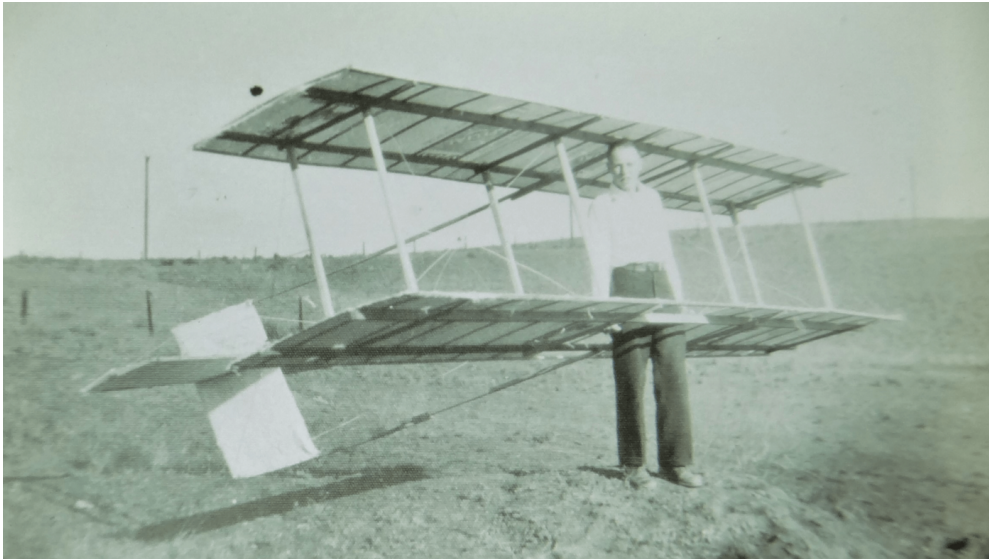

Prater Hogue in the cockpit of the Sperry Special. (credit: Prater Hogue)

### Neither the Ellensburg librarian nor Dad could deter the nascent aeronaut.

*Note that the original author of this article was Prater Hogue, as told to Dean Reynolds who added the hand drawings. Dean's son (and New RCSD contributor) Waid Reynolds submitted it for all of us to enjoy. And don't miss the 'punchline' at the end. — Ed.*

The probable cause of the accident, in the cold and efficient language of a modern accident investigation report, would undoubtedly be: Inadequate engineering design with contributing factors of improper manufacturing processes, pilot error, and pilot inexperience in type.

Such an assessment, however, would neglect a fundamental human factor — the attitude of the Ellensburg Washington Librarian. She seemed to be in a particularly crotchety mood that summer, and she continually chased me out of the library before I could copy the drawings and specifications from that old issue of Popular Mechanics just right.

Time and wisdom have brought forgiveness, because I can now appreciate that she was only trying to protect me from myself. After all, in that long-ago time, a boy studying hang glider construction must have seemed, to her, the equivalent of a modern teenager researching the horticulture of marijuana – and her misgivings very nearly proved to be well founded.

Notwithstanding her resistance to aeronautical progress, my program moved out on several fronts. Financing is the bane of most high-technology projects, and mine was no exception. Two dollars for pine lumber was not easy to come by in that day, and neither was the price of a couple of cedar strips at 30 cents each. The bill of materials also contained a roll of wire, at 69 cents, two dozen flour sacks at 4 cents each, two turnbuckles (“borrowed” from a damaged airplane), and 40 cents’ worth of laundry starch. Starch?... yes, starch; but more about that later.

Vigorous cost control and lots of scrounging kept program costs under \$5.00 (not counting my new slacks). No production line was planned, so I used what is known in the business as “soft tooling” – two saw horses and some old two-by-fours.

In Ellensburg the summer days are long and hot, but I didn’t notice the heat as I was busily sawing, bending, tying, and gluing.

My Dad helped, but if he knew that he was ripping out wing spars on his circular saw, he didn’t let on. Building a glider keeps a boy out of the pool hall; but, if my parents had been gifted with precognition, they probably would have put a cue in my hand and sent me off to town.

At length, the final wire was rigged, and the last of the flour sacks had been stretched over wing and tail. It was time to begin starching...yes, starching. Its purpose was to fill the pores in the flour sack fabric in order to prevent air from leaking through and spoiling the lift of the wings.

Coat after coat was applied, until the wings and tail surfaces began to take on a sheen that rivalled the famous twenty-coat, hand-rubbed gloss of a Staggerwing Beech, albeit with no pretense of the water resistance of the Beach. Fortunately, Ellensburg flies in a high, dry, and windy mountain basin, and all-weather flight was not an operational requirement.

When at last the final coat of starch was complete, she was a gleaming beauty of a stick and wire biplane emblazoned here and there with a colorful trademark proudly proclaiming “SPERRY SPECIAL” to the waiting world.

For those who never saw a hang glider, the cockpit consisted of a pair of fore and aft parallel bars on which the pilot clung like an acrobat; and, with an economy of design seldom seen in this day of specialization, the landing gear (the pilot’s feet) was combined with the flight control system. Airborne, the feet were to be thrown this way and that in order to effect a degree of control.

The propulsion system was a two-stage affair which also relied on the pilot’s undercarriage to build up a store of potential energy by climbing a hill, after which the glider would be boosted to takeoff velocity.

Finally, under the inexorable pull of gravity the machine and its pilot would float gently to the earth (so it said in the magazine). The whole concept was elegantly simple – no moving parts, no electronic control system, no instruments, no engine, no fuel system – so elementary that nothing could go wrong.

Like all good aircraft manufacturers, I conceived a multi-phase program of tests designed to prove the inherent safety and airworthiness of my machine. Phase One would consist of ‘taxi’ test during which I would run into the wind to sense the forces acting on the wings and tail.

Phase Two would progress to very short flights in which I would launch myself from the tops of small knolls and learn the feel of flying and how to control the glider.

Phase Three would progress to longer and longer missions until at last, I would launch myself from the top of a formidable ridge called Craig's Hill for the ultimate in long-range missions. I was confident that this logical progression would lead to success. After all, it was a path well trodden by illustrious pioneers like Otto Lilienthal, Octave Chanute, and brothers Wright.

Phase One and Two proceeded rapidly, and I was soon hopping from one knoll to another logging flight time in intervals of seconds. Only minor modification and repairs were needed, and I gained confidence as the glider seemed willing to carry my weight and docile enough to control.

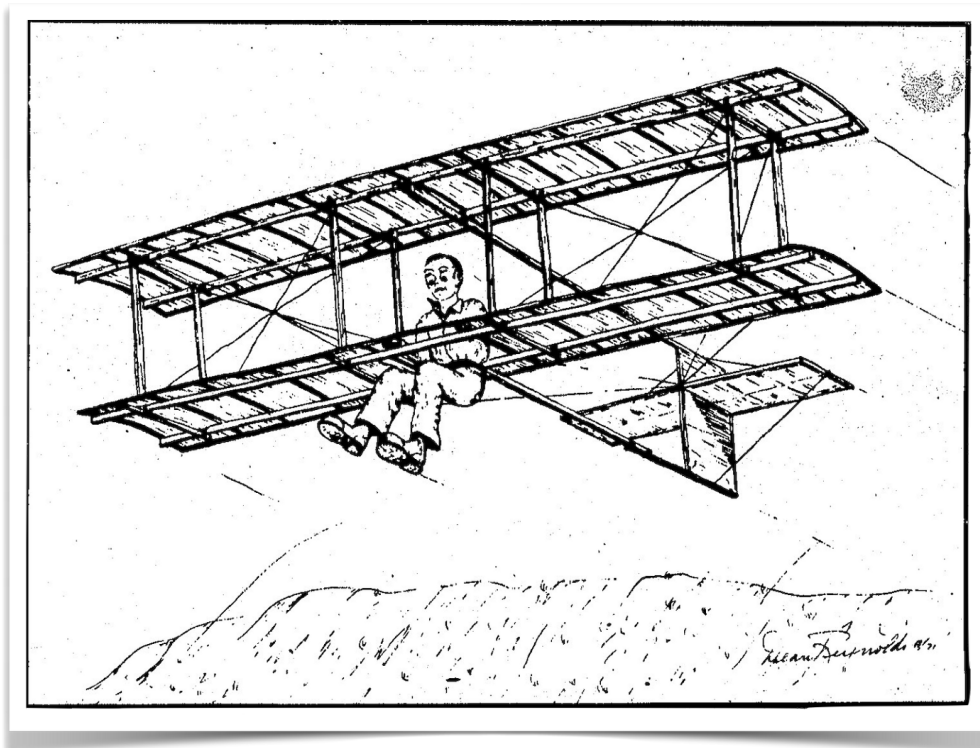

No good test program would be complete without a problem and mine was that I could not seem to find an intermediate-sized hill in the neighborhood. The leap from Craig's Hill seemed mighty long and lonely. Torn between the desire to fly and the fear of it, I searched my soul for awhile.



The test program had been going without a hint of trouble, and I had accumulated some thirty-six seconds of pilot-in-command time in some thirty-odd flights. Why not? I asked myself, and there was no answer. Terms like phugoid oscillation, tail moment arm, and stabilizer trim angle had not entered my vocabulary. I didn't know that they, the librarian, and the author of the magazine article had set an unseen trap for me.

Anyone who can slip away from home and avoid curious acquaintances while wearing a hang glider should give lessons to the CIA, but somehow I succeeded. In due time I found myself engaged in pre-flight activities on the lofty top of Craig's Hill. These consisted of catching my breath after the climb, and mustering my courage.

I didn't dare to look over the edge; but if I had, I would have seen that the familiar Ellensburg wind was sweeping up the hill, making a strong updraft that could not be perceived from my sheltered position.

At last, the decision was made, and the glider stiffened in the breeze created by my running feet as I hurled myself toward the lip of the hill. All too soon came the scalp-prickling realization that my feet were no longer touching the ground, and that I was looking down on the world from an awesome height.

Moreover, the front of the glider was pointed skyward at an angle that even I, in all my innocence, knew was too steep. The sough of the wind in the struts and wires whispered down the scale as the front of the glider tilted ever farther toward the zenith. There was a timeless moment of hanging suspended between brown earth and blue sky; then came the stomach-wrenching, falling-elevator sensation as the stall break came.

We fell, seemingly forever, as the glider nosed earthward and began to dive. The wind notes climbed the scale, and the earth rushed upward at a terrifying speed. Half paralyzed with fright, I tried to work my way tailward to correct that hair-raising dive; and at long last, the front of the glider began to rotate upward as I clung desperately to my parallel

bars while the roaring wind and the g-forces tried to dislodge my white-knuckled hands.

The glider soon reached level attitude, but my relief was short-lived. The nose-up rotation continued; and, in spite of my best effort, the whole terrifying sequence was repeated – stall, fall, dive, upward swoop.

Like a repetitive nightmare, it began a third time, but there was a profound difference. As the glider nosed down and began to pick up speed, its flight path abruptly intersected the solid earth. There was a pride-shattering impact, a small mushroom cloud of dust and starch erupted skyward, and I was lying in a pile of instant splinters.

I lay there a moment while the dust cleared, half expecting a transparent replica of me to soar skyward like a scene from an old movie. When it didn't happen, I slowly arose and untangled myself from the wreckage of splintered wood, torn cloth, and clinging wire. Stepping clear at last, I brushed off the dust as best I could, and then trudged homeward across that hot and dusty field with never a backward glance.

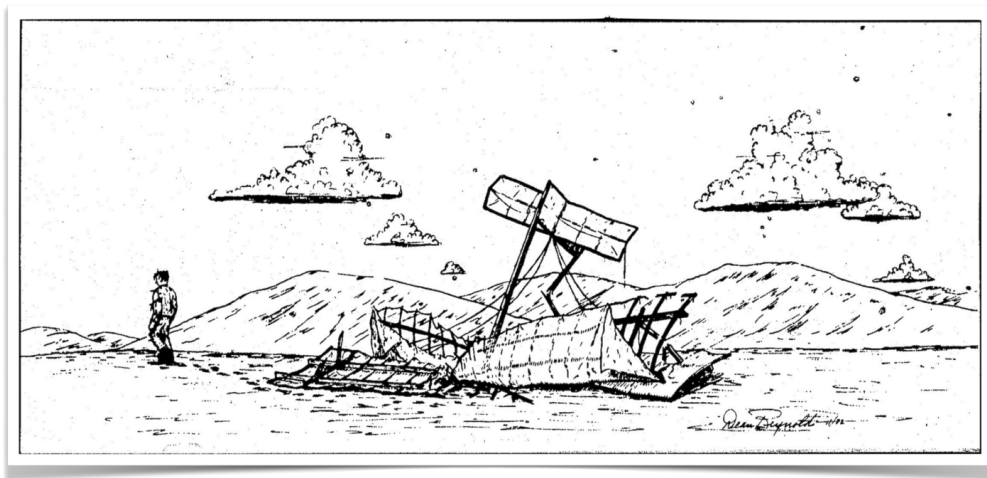

My father was working in the front yard as I limped home, trying not to call attention to the holes in the knees of new slacks and the sleeve that was nearly separated from my jacket. He demonstrated great sympathy and understanding by resisting the temptation to engage in

a game of 20 questions which would have sandpapered my already-bruised nerve ends, and further diminished by battered ego.

Early next morning I initiated an official investigation into the cause of this accident. From the wreckage it was determined that the fuselage was approximately 27 inches longer than the designer intended. Further investigation revealed that this error stemmed from the fact that the magazine containing the glider plans was bound into a larger volume which could not be opened fully. The crucial dimension was hidden, and an engineering estimate was substituted.

This error, in itself, might not have been too serious; but it was also discovered that the horizontal stabilizer had been fastened to the fuselage at the wrong angle causing the glider to be trimmed nose-high in flight.

Hang gliding is being rediscovered now, and youths are flinging themselves off hills all over the country even as I did, and some are not so lucky. I would like to pass along some advice from some old pioneers. Call it a message from Otto, Octave, Orville, and Wilbur. Proceed slowly fellows. Find that intermediate hill!

*As described in the interview linked below, Prater Hogue eventually went on to become head of Boeing's Accident Investigation team. — Ed.*

## Resources

- [Prater Hogue Interview](#) — A transcript of an extensive interview conducted by Central Washington University as part of their CWU Retirement Association Interviews presumably to capture the life stories of CWU alumni.

*Transcript from the original text by RCSD Editorial Assistant Michelle Klement. Read the [next article](#) in this issue, return to the [previous article](#) in this issue or go to the [table of contents](#). A PDF version of this article, or the entire issue, is available [upon request](#).*

Unlisted



## Stamps That Tell a Story



### A tribute to Ernő Rubik's classic *Futár* and *Cimbora* designs.

A set of two stamps was issued by the Hungarian Post Office, honouring the 17th Old Timer Rally in Europe and the 60th anniversary of glider flying in Hungary. A total of 267,300 sets of perforated stamps were printed, with an additional 4,700 sets of unperforated stamps.

The Hungarian gliding movement began in 1929 at the Farkashegy gliding site and the 17th International Old Timer Rally was held from July 22 to 30, 1989 at the Budakeszi Farkashegy Airport, about one mile from the original site and some seven miles outside Budapest. About 800 participants from 15 nations came with 85 beautifully restored antique and vintage sailplanes.

The 3Ft (Forint) stamp shows the R-22 *Futár* sailplane. This single-seater, designed by Ernő Rubik, was built in 1944 by the Aero Ever Kft Airplane Factory in Esztergom. At the time it was a very modern, high

performance sailplane of wooden construction, incorporating many innovative ideas.

It reportedly has excellent flying characteristics and good manoeuvrability. The view from the cockpit was unparalleled at the time, however for today's pilots it almost gives the impression of flying a two-seater.



Left: The Rubik R-22 'Futár' (credit: Fortepan / Zoltán Mészáros) | Right: The Rubuk R-11 'Cimbora' (credit: Fortepan / Ferenc Nasztanovics)

Eight of these sailplanes were produced. A restored version, as shown on the postage stamp, participated in the rally and many vintage glider pilots were allowed to fly this machine.

To broaden a stamp collection, one could add 'glider flown mail'. Fred Hefty (son of Frederick V. Hefty, test pilot of all the Rubik designed sailplanes) from California, carried 450 pieces of souvenir mail in the *Futár*. These envelopes (see key photo above title) use one of these colourful stamps as postage, and they also bear a special postmark and a cachet (the imprinted logo on the left hand side of the envelope).

The second stamp in this set, the 5Ft stamp, shows the open cockpit two-seater R-11B *Cimbora* sailplane. This machine was also designed by Ernő Rubik in 1941, also built by the Aero Ever Kft (in 1944).

It was the first Hungarian two-seater built for training purposes only. The nicely restored *Cimbora*, coming in to land at the glider port of Farkashegy, with the administration building in the background, is shown.

During the 1989 Old Timer Rally it was used for winch check flights and passenger rides. The owners are now taking it to Old Timer Rallies throughout Europe.

It may be of interest to know that in 1948 Géza Vass, with Endre Lacza as passenger, set a Hungarian duration record of 25 hours and 7 minutes in a *Cimbora*.

Input for this article came from Linn Buell, Fred Hefty and Jan Scott, who were participants at the Rally.

©2002, 2022

## Glider Patents

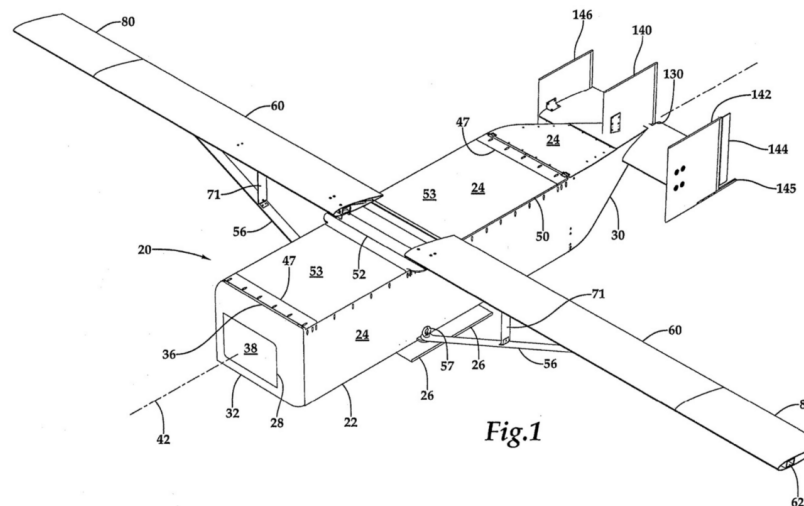

### US 2018/0086449 A1: Single Use Logistical Glider

*This is the second in our series of glider-related selections from the files of the US Patent and Trademark office (see Resources, below). They are presented purely for the interest and entertainment of our readers. They are not edited in any way, other than to intersperse the drawings throughout the text. Disclaimers: a) Inclusion of a given patent in this series does not constitute an expression of any opinion about the patent itself. b) This document has no legal standing whatsoever; for that, please refer to the original document on the USPTO website . – Ed.*



(19) **United States**

(12) **Patent Application Publication**  
**Sarigul-Klijn et al.**

(10) **Pub. No.: US 2018/0086449 A1**

(43) **Pub. Date: Mar. 29, 2018**

(54) **SINGLE USE LOGISTIC GLIDER**

*B64C 3/56* (2006.01)

*B64C 25/52* (2006.01)

*B64D 17/80* (2006.01)

(71) Applicants: **Martinus M. Sarigul-Klijn**, Dixon, CA (US); **Maurice P. Gionfriddo**, Dixon, CA (US); **Nesrin Sarigul-Klijn**, Dixon, CA (US)

(52) **U.S. Cl.**

CPC ..... *B64C 31/02* (2013.01); *B64C 3/185*

(2013.01); *B64D 17/80* (2013.01); *B64C 25/52*

(2013.01); *B64C 3/56* (2013.01)

(72) Inventors: **Martinus M. Sarigul-Klijn**, Dixon, CA (US); **Maurice P. Gionfriddo**, Dixon, CA (US); **Nesrin Sarigul-Klijn**, Dixon, CA (US)

(73) Assignee: **Logistic Gliders Inc.**, Dixon, CA (US)

(21) Appl. No.: **15/715,016**

(22) Filed: **Sep. 25, 2017**

**Related U.S. Application Data**

(60) Provisional application No. 62/400,527, filed on Sep. 27, 2016.

**Publication Classification**

(51) **Int. Cl.**

*B64C 31/02* (2006.01)

*B64C 3/18* (2006.01)

## Abstract

A disposable airdropped glider. The glider body is constructed from precut panels cut from (MDO) or (HDO) plywood and assembled with pocket-screw joinery or piano hinges. A skid board forms a landing surface and a cargo deck roll-off surface. The glider has pivoting wings and struts. The glider has a triple-tail, a flat nose and honeycomb paperboard panels between the nose and the cargo. Wings are pivoted from a position overlying the fuselage to a flying position by gas springs in wing spars which are compressed by a chain attached to the fuselage through a rotating bracket such that the gas springs are compressed when the wings are folded. The airfoils are plastic extrusions with openings that hold the wing spars and co-formed jury spars which attach the upper and lower surface of the wing. A parachute uses a part of the tail structure to form a deployment drogue.

## Cross References to Related Applications

[0001] This application claims priority on U.S. Provisional Application N°62/400,527 filed Sep. 27, 2016, which is incorporated by reference

herein.

## **Statement as to Rights to Inventions Made under Federally Sponsored Research and Development**

[0002] This invention was made with government support under contract number D16PC0011 awarded by DARPA. The government has certain rights in the invention.

### **Background of the Invention**

[0003] The present invention relates to the resupply or delivery of payload by airdrop or gliders.

[0004] In tactical combat defending a hardened position, or engaging the enemy behind their lines has considerable tactical advantage. In the defense of a hardened position the defenders are considerably less exposed to fire than the attackers and thus can withstand a superior enemy. Further, if the enemy cannot reduce such a hard position and bypasses the position, it leaves an active fighting force in its rear, which either ties down considerable enemy forces, or leaves the defenders capable of conducting sorties to cut supply lines and to conduct attacks from the rear. Similarly, troops operating behind enemy lines have a tactical advantage including the element of surprise and the relatively soft targets presented by lines of communication and supply depots. However, both these tactical advantages depend on an ability to resupply behind enemy lines or through superior forces.

[0005] Where air superiority is maintained, resupply by air is possible. However, conventional approaches can often deliver the supplies to the enemy or subject valuable and limited assets to enemy fire. What is needed is a method of air resupply which is highly accurate, low

cost, and can be delivered without overflying or landing where the enemy can effectively attack the supplying aircraft.

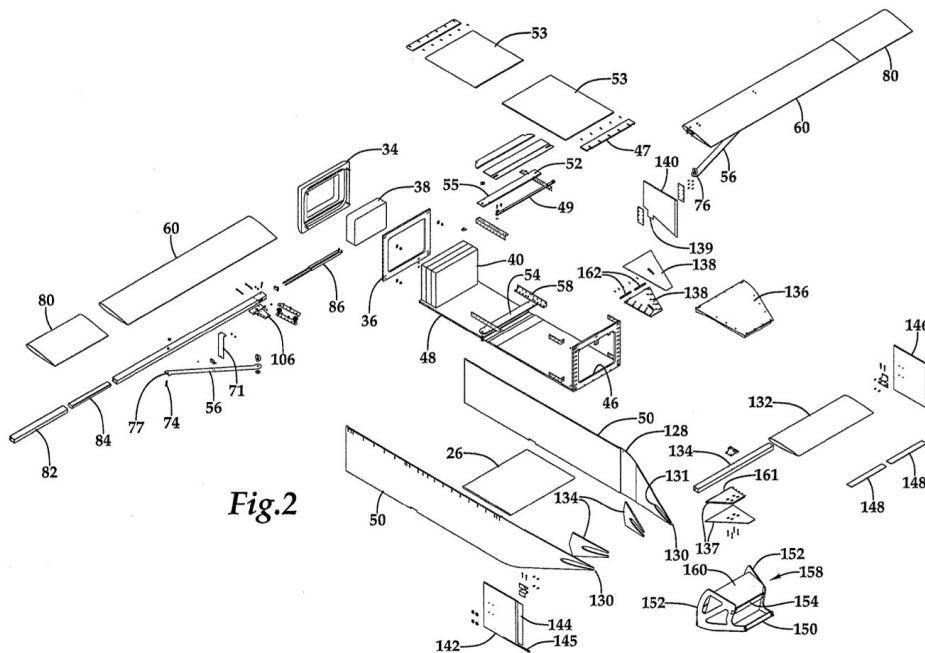

Fig.2

## Summary of the Invention

[0006] The air resupply device of this invention is a disposable glider of low cost which can be dropped from an aircraft and glide to a landing point up to 130 statute miles from the drop point, depending on the altitude at which the airplane is dropped. The glider body is constructed from precut panels cut from medium density overlay (MDO) plywood which resists water, weather, wear and degradation. High density overlay (HDO) plywood with a more rugged, smoother surface can also be used. The plywood panels are joined with one inch self-tapping pocket hole screws which form a high-strength connection between the panels. Pocket-screw joinery involves drilling a hole at an angle e.g., 15 degrees into one workpiece, and then joining it to a second workpiece with a self-tapping screw. Pocket screws require only one side of a joint to be drilled, which can be done on automatic equipment. The pieces are joined with glue such as Titebond® III and self-tapping pocket hole screws which form their own hole in the second workpiece. Using pocket hole screws

eliminates the need to access the inside of the joint, allowing the cargo space in the fuselage to be closed from the exterior.

**[0007]** Assembly of the glider begins with a rectangular skid board which forms a surface on which the glider can roll off the cargo deck of a drop aircraft. The glider is formed as a long narrow rectangular plywood box or fuselage mounted to the skid board, to which is attached two wings and a triple-tail. A blunt picture frame nose of concrete containing an energy absorbing material is attached to a forward frame which forms the forward end of the fuselage. Two sides of the box extend rearward of the forward frame past an aft frame where the sides converge, coming together to form a tail structure. Portions of the side extending to a point form a slot in which the horizontal stabilizer is mounted. The triple-tail having three vertical stabilizers is formed by two outboard fins mounted to the ends of the horizontal stabilizer and a third fin is mounted between the outboard fins along the principal axis of the fuselage. One of the outboard fins supports a rudder and the horizontal stabilizer mounts a port and starboard elevator.

**[0008]** The glider has two mirrored wings having wing spars which are mounted to the fuselage by a pivot pin, and a wing strut. The wing struts are pivotally mounted to the ends of a metal strap which spans the fuselage between the skid board and the fuselage and forms a support loop below the center of gravity (CG) of the glider. The wing and the struts are pivoted from a storage and launch position where the wings overlie the fuselage, to a flying position by a pair of gas springs in each wing spar which are compressed through a chain attached to the fuselage through a rotating bracket such that the gas springs are compressed when the wings are folded. The wings need not be locked open, rather, the gas springs provide both the deployment force and the force to keep the wings in the deployed position. The wings and the horizontal stabilizer are cut from an ABS plastic extrusion which forms the wing surfaces. The wing extrusion as formed, has a rectangular walled opening that holds the wing spar;



the extrusion also has a plurality of jury spars which attach the upper and lower surface of the wing.

**[0009]** The aft bulkhead and the tail form a pyramidal frustum shaped space in which a downwardly opening drawer is mounted. A terminal landing parachute such as a Low Cost Low Velocity Parachute (LCLV) is stored in the drawer and arranged such that when the drawer is released from the glider the drawer forms a drogue which extracts the parachute such that it rapidly and reliably inflates. The drawer is mounted to open downwardly so it detachably rotates about the aft most edge which holds the drawer to the tail. The front of the drawer is releasable by an actuator mounted to the aft frame such that the leading edge of the bottom of the drawer, which forms the lower skin of the tail, when released rotates into the slip stream of the glider and is pulled open and falls away and acts as a drogue which pulls the landing parachute out from the glider. The parachute can be deployed to land the glider vertically on its nose in forested or urban terrain as well as small clearings.

**[0010]** It is an object of this invention to provide an expendable logistic delivery glider which provides for air drops with a standoff of over 130 statute miles.

**[0011]** It is another object of this invention to provide an expendable logistic delivery glider which is low cost.

**[0012]** It is another object of this invention to provide an expendable logistic delivery glider which deploys a terminal landing parachute so it can be used in forested or urban terrain as well as small clearings.

**[0013]** Further objects, features and advantages of the invention will be apparent from the following detailed description when taken in conjunction with the accompanying drawings.

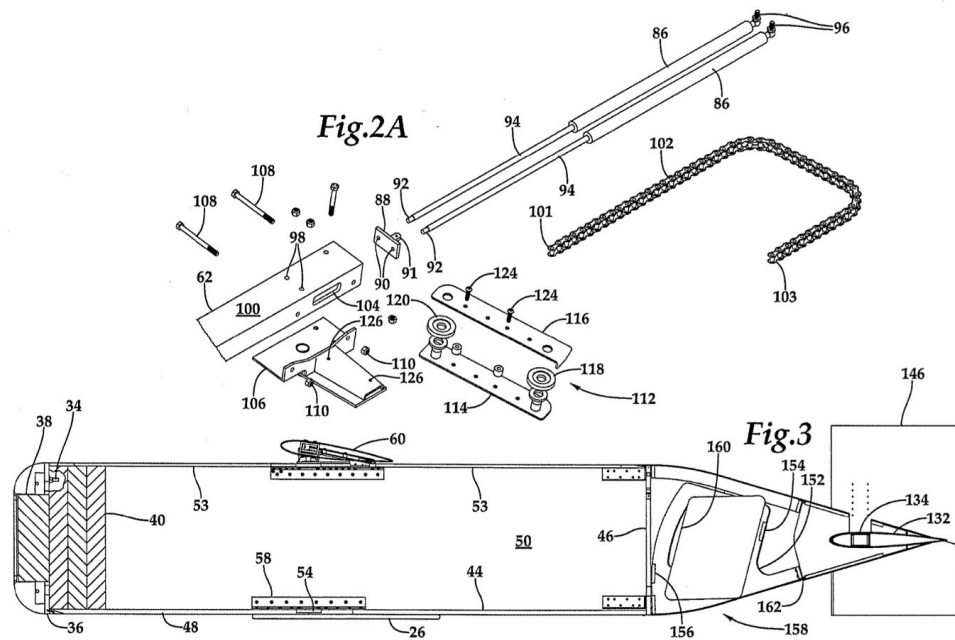

## Brief Description of The Drawings

[0014] FIG. 1 is an isometric view of the logistic glider of this invention.

[0015] FIG. 2 is a partly exploded isometric view of the logistic glider of FIG. 1.

[0016] FIG. 2A is an enlarged isometric exploded view of a detail of the logistic glider shown in FIG. 2.

[0017] FIG. 3 is a cross-sectional view of the logistic glider of FIG. 1.

[0018] FIG. 4 is an illustrative perspective view of the parachute release mechanism positioned in the tail section aft of the cargo section of the logistic glider of FIG. 1.

[0019] FIG. 5 is a cross-sectional view of an extruded wing section and a wing spar to which the wing section is mounted to the logistic glider of FIG. 1.

[0020] FIG. 6 is a partial side elevational, cross-sectional view of the wing deployment mechanism positioned on the fuselage bridging wing spar, all of the logistic glider of FIG. 1.

[0021] FIG. 7 is a top plan view of the fuselage bridging wing spar with the wing cutaway to show the wing deployment mechanism of FIG. .

[0022] FIG. 8 is a schematic view of the logistic glider of FIG. 1 showing the instrumentation and control and actuators used to control the logistic glider of FIG. 1.

[0023] FIGS. 9A-D are a series of schematic views of the steps used to rig the logistic glider of FIG. 1 for deployment of the wings.

## Description of the Preferred Embodiments

[0024] Referring more particularly to FIGS. 1–8, the logistic glider 20 is shown in FIG. 1. The glider 20 is constructed of low cost materials and for ease of assembly such that no part of the glider need be recovered for reuse. The fuselage 22 of the glider 20 is constructed as a rectangular box formed of medium or high density overlay plywood panels 24. This type of plywood is also known as signboard; it is impregnated with a resin which produces a smooth water resistant surface but has a cost not significantly greater than that of ordinary structural plywood. As shown in FIG. 2 the fuselage begins with a skid board 26 which forms the lowermost structure which is attached to the fuselage proper. The skid board 26 forms a launch skid which remains with the glider 20 after it is airdropped from a cargo aircraft used to deploy the glider. The skid board obviates the need for any component other than the logistic glider 20 from being dropped from the aircraft as part of the deployment process. This is an important consideration because any object falling from the aircraft represents a hazard to persons on the ground, and therefore extraneous structures being dropped are to be avoided.

[0025] The main body of the fuselage 22 as shown in FIG. 1 comprises: beginning with the nose 28 and extending to the tail 30: a nose frame 32 constructed of cast concrete which supports the logistic glider 20 when gliders are stored vertically, either in forward or rear logistics depot, a deployment sling, or during shipping. The nose

frame **32** has an internal steel frame parts of which form four threaded bolts **34** which serve to attach the nose frame **32** to the forward structural frame **36**. The central opening of the frame is filled with a first portion **38** of energy absorbing material such as paper honeycomb or aluminum honeycomb bonded to face sheets. The energy absorbing material, when subjected to high loads, crushes and therefore absorbs energy through the work performed in deforming of a honeycomb structure. A second and larger portion **40** of energy absorbing material, extending 9 inches along the fuselage body axis **42** forms the forward end and extends to the top of cargo bay **44** as shown in FIG. **3** which holds the payload which is delivered by the logistic glider **20**. The cargo bay **44** extends between the forward frame **36** and aft frame **46** wherein the forwardmost section of the cargo bay is occupied by the energy absorbing material **40**. The cargo bay **44** is further defined as shown in FIG. **2** by a floor panel **48**, two side panels **50** which are joined to each other and the frames **36**, **46** by pocket screws **51** as shown in FIG. **6**. A fuselage bridging wing spar **52** is composed of an aluminum spar **55** to which the pivot shaft **66** of a pivot bracket **106** is mounted and an anchor bar **49** to which the anchor block **126** is mounted and several stiffling members. Two upper closeout panels **53** enclose the cargo bay **44** on either side of the bridging wing spar **52**. Anti-racking bars **47** are screwed to the forward frame and the rear frame **46** as shown in FIG. **1**.

**[0026]** As shown in FIG. **2**, mounted to the interior surface of the floor panel **48** is an aluminum load transfer strap **54** to which two wing struts **56** are pivotally mounted with bolts **57**. The side panels **50** attachment to the floor panel **48** is reinforced where the load strap **54** penetrates the sidewalls by aluminum L-channels **58** with holes for fasteners. L-channels are also used to strengthen the fuselage bridging wing spar **52** and the aft frame **46**. The load path between the payload and the wings **60** principally passes through the wing struts **56**, which in combination with the load strap **54** forms a cradle which approximately underlies the center of gravity of the fuselage and the contained payload. L-channels **58** are attached and



positioned so as to distribute this load path into the floor panel **48** and the side panels **50**.

**[0027]** The wings of the logistic glider **20** are constructed of an aluminum wing spar **62** formed by an aluminum rectangular extrusion which supports a wing profile made from an ABS plastic extrusion **64** as shown in FIG. **5**. The wing spar **62** is pivotally mounted to the fuselage bridge spar **52** at an angle of attack of  $8^\circ$  by a pivot shaft **66** shown in FIG. **6**. The wing extrusion **64** structurally supports the aerodynamic lift surfaces **68** and which together with the remaining structures provide a 16:1 lift to drag (glide) ratio. The lift to drag (glide) ratio can be increased by a longer wing extension **80** to 20:1. The aerodynamic lift surfaces **68** have a thickness of approximately 0.12 inches and have wing wise ABS jury spars **70** with a thickness of approximately 0.06 inches. The wing extrusion **64** is formed without sink marks i.e. imperfection of the lifting surfaces due to the contraction of the plastic overlying the jury spars, to form smooth lift surfaces **68**. The wing spar **62** is an aluminum tube extrusion, with dimensions of 3×2 inches with  $\frac{1}{4}$  inch wall thickness, and is positioned between two more widely spaced jury spars **72**. The wing spar **62** is fixed with respect to the wing extrusion **64** by a bolt **74** which passes through the wing spar **62** and attaches to the wing strut **56** by a bolt passing through an opening **75** formed in the wing strut. In a similar way jury struts **71** are connected to the wing struts **56** and in turn are connected to the wing spar **62** and further fix the wing extrusion **64** to the wing spar. The wing strut **56** is formed of a relatively thin aluminum bar which is bent so as to form a lower flange **76** with the bolt hole **78** through which the eye bolt **57** passes to attach the lower flange to the load strap **54**. The wing struts **56** are also bent to form an upper flange **77** in which the bolt opening **75** is formed. Because the wings **60** are moved from a stored position to a deployed position by rotation of the wing spar **62** about the pivot shaft **66**, the wing struts **56** must be free to rotate about the eye bolt attaching the strut to the fuselage **22**, and to rotate about the bolt **74** which attaches the wing strut to the wing spar **62**. This functionality is provided by using collar washers or simply low friction washers. As

shown in FIG. 2, the wings 60 and the wing extensions 80 are formed from the same wing extrusion 64, and are supported on an extension spar 82. The extension spar 82 joined to the wing spar 62 by a friction fit connector 84 such as a wooden member which is friction fitted during assembly of the wings 60. The use of the wing extensions 80 allows the wings to be unassembled to fit within the cargo bay 44 of the fuselage which facilitates shipping by reducing the shipping volume of the logistics glider 20 when only partially assembled.

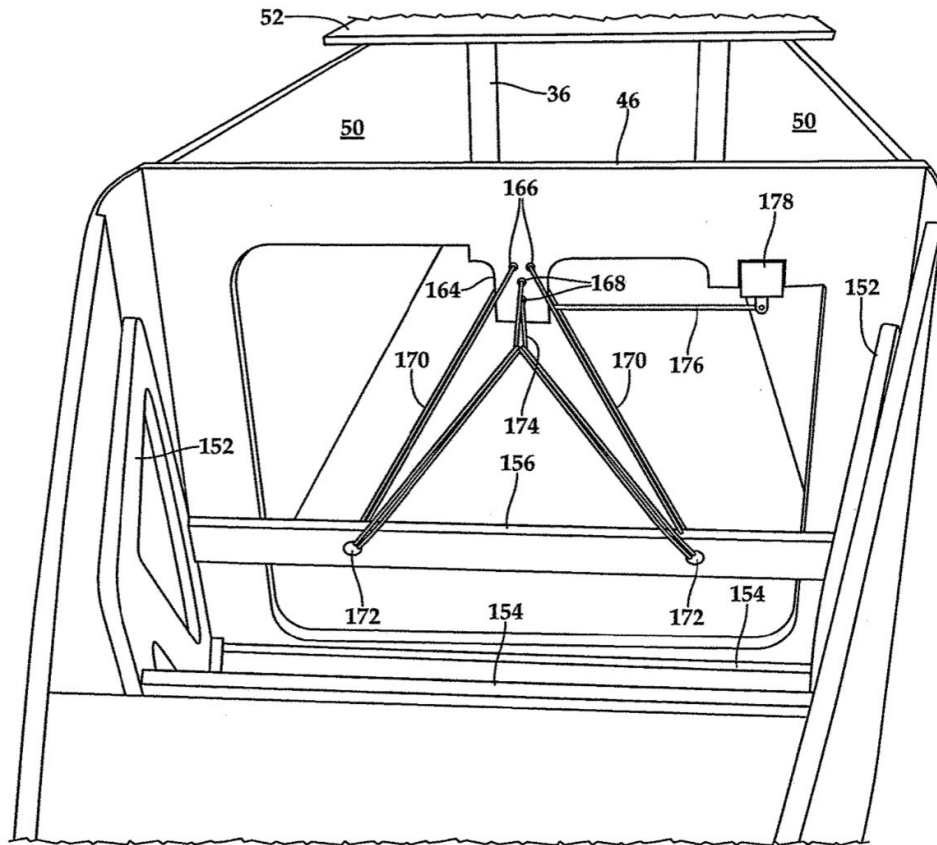

*Fig.4*

[0028] The wings 60 are pivotally mounted for storage and for simplicity in deployment i.e. it would be difficult and limiting if the wings had to be deployed before the logistics glider 20 has departed from the aircraft from which they are being dropped. The wings are deployed by a mechanism and an energy storage system mounted internally to the wing spar 62. FIG. 2A is an enlargement of the deployment mechanism and energy storage system shown in FIG. 2. The basic mechanism consists of the spring which is compressed by

a tension member when the wing is in a folded position. Energy in the spring is released as the tension member is allowed to feed into the wing spar by rotation of the wing about the pivot shaft **66**. Referring now to FIGS. **2A**, **6** and **7** the components of the deployment mechanism comprise two gas springs **86** which are joined together by a bracket **88** which has portions forming two openings **90** which receive the ends **92** of the pistons **94**. Opposite ends of the gas springs **86** have threaded fasteners **96** which are mounted to openings **98** in the upper surface **100** of the wing spar **62** so that when assembled the gas springs **68** are completely contained within the rectangular aluminum extrusion forming the wing spar **62**. The spring bracket **88** has a chain connection protruding from a face of the bracket pointing towards the gas springs **86** to which a first end **101** of a chain **102** is mounted. Still referring to FIG. **2A** the wing spar **100** has a slotted opening **104** facing the aft direction when the wing is deployed. The spar is mounted to a pivot bracket **106** by attachment bolts **108** and nuts **110**. A chain guide **112** comprised of a lower plate **114** and an upper plate **116** and a front sprocket **118** and a rear sprocket **120** spaced apart and mounted for rotation between the upper and lower plates **114**, **116**. The chain guide assembly **112** is mounted by screws **122** to threaded holes **124** in the pivot bracket **106**. The second end **103** of the chain **102** is attached to an anchor block **126** as shown in FIG. **7**. The wing spar **62** is attached to the pivot bracket **106** by the horizontal bolts **108** and a vertical bolt **128**. The pivot bracket **106** and the chain guide **112** and the spar **62** are thus all rigidly attached and move together, so that when the wing is in the stored position overlying the fuselage, the chain guard **112** is parallel to the fuselage bridging spar **52** and perpendicular to the fuselage **22**. When the wing is deployed the forward sprocket **118** is closely adjacent to the anchor block **126** when stowed forward sprocket is displaced forwardly towards the nose **28** and laterally towards the center of the fuselage **22**. As the chain **102** does not change in length, the added path length must be made up by compressing the two gas pistons **94**. The gas springs **68** have a combined spring constant of 150 pounds which opens the wings and

holds them in the forward position eliminating the need for a latch hold open the deployed wings. With the lift to drag ratio of 16 and an overall weight of 2200 lbs. total drag is approximately 137.5 lbs. Assuming all the drag is caused by the wings, there is a force of about 62.5 lbs acting on each wing at the 44% cord along the length of the wing, such that turning movement about the pivot pin remains at all times substantially less than the 300 lbs. tension in the chain.

**[0029]** Referring to FIGS. 9A-D the wings **60** are rigged to a static line **109** which is tied to form a large loop **111** and knotted to a ring **113** holding an aluminum pin **115** as shown in FIG. 9A. The loop **111** is laid over the folded wings **60** as shown in FIG. 9B. As shown in FIG. 9C the large loop **111** is wrapped about both folded wings **60** forming a first loop end **119** and a second loop **121**. A third loop **123** forms part of the large loop **111** opposite the pin **115**. As illustrated in FIG. 9D the first loop **119** is overlapped with the second loop **121** and the third loop **123** is pulled through loops one and two. The pin **115** is then placed through the third loop **123**. One or more rubber bands **125** attached to the ring **113** are stretched from the ring around the first, second and third loops and about the end of the pin **115** such that the pin passing through the third loop and between the third loop and the overlapping first and second loops such that all loops are constrained by the pin **115**. The gas springs **86** through the wing **60** apply tension to the first, second and third loops which are restrained by the pin **115** until the glider is dropped. After the drop the static line comes under tension from the weight of the glider and pulls the pin **115** which releases the first, second and third loops which unwind freeing the wings **60** to pivot to their deployed positions. Finally the large loop **111** is then pulled away with the static line **109**.

**[0030]** Referring again to FIG. 2, the plywood sides **50** as they extend aft are tapered and bent inwardly, which is facilitated by routing out a substantial portion of the plywood thickness in the region **128** which begins just aft of the aft bulkhead **46** the routed section allows the two sides **52** to meet at a point **130**. Just forward of the meeting point is a slot **131** in the shape of the wing extrusion **80** such that a



horizontal stabilizer **132** formed by a section of extrusion together with a horizontal stabilizer spar **134** can be fixed in the slot **131**. Plywood doublers **138** as shown in FIG. 2 reinforce the slot **131**. A framed upper panel **136** is held between the sides **50** between the aft frame **46** and the horizontal stabilizer **132**. Thin metal channels **162** connect to the forward edge of the panels **138** as shown in FIG. 2 and support the aft end of the upper framed panel **136**. Smaller upper doubled trapezoidal panels **138** are screwed to the portions of the side walls which extend over the horizontal stabilizer **132**. The trapezoidal panels **138** have a slot for mounting a protrusion **139** of a vertical stabilizer **140** which can be attached with reinforcing metal plates as shown in FIG. 2. A port vertical stabilizer **142** is mounted to the horizontal stabilizer **132** by brackets as shown in FIG. 2 and to a rudder control surface **144** mounted to the port vertical stabilizer. To protect the rudder control surface **144** a metal channel **145** underlies the control surface, because when hoisted the glider **20** the tail **30** and more particularly the control surface **144** may be the last part of the glider **20** to leave the ground. A starboard stabilizer **146** is similarly mounted to the starboard side of the horizontal stabilizer **132**. On either side of the central vertical stabilizer **140** left and right elevators **148** are mounted to the trailing edge of the horizontal stabilizer **132**.

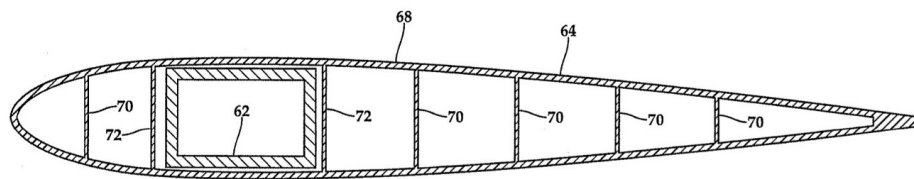

*Fig.5*

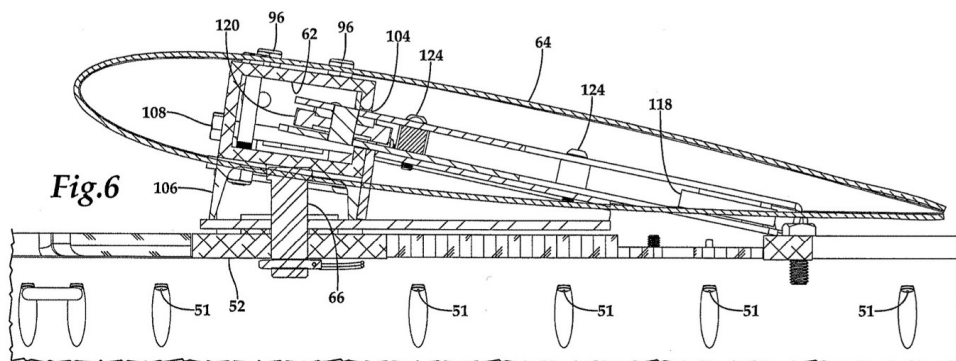

*Fig.6*

**[0031]** On the underside or belly of the fuselage is mounted a lower frame panel **150** which has upwardly extending sides **152** which are connected by an aft cross member **154** as shown in FIGS. **3** and **4** and a forward cross member **156** which forms a downwardly rotatable drawer **158** which contains a parachute **160**. Thin metal channels **161** are connected to the forward edge of the plywood of the upper doubter pane **137** as shown in FIG. **2** and support the aft end of the lower framed panel **150**. Referring now to FIG. **4**, the aft frame **46** has an attachment protrusion **164** which has four holes, two upper holes **166** and two lower vertical holes **168**. Through each hole **166**, an attachment line loop **170** is threaded, the loops **170** also pass through holes **172** in the forward cross member **156** and are retained in a release loop **174** which is retained on the opposite side of the protrusion **164** by a release pin **176** which is pulled by a servo actuator **178**. When the actuator **178** pulls the pin **176**, one end of the release loop **174** is freed which allows the line loops **172** to pass through the holes **172** in the forward cross member **156** which allows the downwardly rotatable drawer **158** containing the parachute **160** to rotate, under the weight of the drawer and the parachute, downwardly while still supported for a time by the metal edge **162** thus bringing the forward edge of the drawer into the slip stream underneath the bottom panel **58** of the glider **20**. The slip stream pulls the drawer **158** and the parachute **160** away from the glider **20** opening the parachute **160** through the action of a static line (not shown) attached to the aft frame **46**. The force of the static line pulls the parachute **160** from the drawer **158**, aerodynamic forces cause the drawer, which is still attached to the parachute canopy in such a way as to act as a drogue, to fully extract the parachute so that it rapidly inflates. Riser lines (not shown) connect the parachute to the tail of the glider **20** causing the glider to lose forward velocity so that the glider stalls and the glider begins a vertical descent under the parachute canopy.

**[0032]** The glider **20** has two landing modes, the first is a belly landing on the skid board **26**, the second mode deploys the parachute after the glider makes a high-speed low approach to the drop point, then executes a maximum rate of climb pull up to approximately 500–

1500 feet where the parachute is deployed. The first mode of a belly landing necessarily has somewhat higher reliability as all possibilities of parachute deployment failure are eliminated, and therefore, is used wherever terrain permits a controlled belly landing. Where the terrain is urban, mountainous or forested, the parachute landing mode will maximize payload delivery precision and success. The wings **60** which are not locked in the open position can be forced closed by the weight and the downwardly directed momentum of the glider and payload thereby reducing the likelihood the wings will impede the glider and payload from reaching the ground.

**[0033]** The glider avionics are shown schematically in FIG. **8**. The glider **20** has six servo controls: two wing aileron servos **180** which control the wing flaps **182**, two elevator servos **184** which control the left and right elevators, a rudder control servo **186**, and a parachute release servo **178**. The glider employs the following sensors and status indicators: a Pitot tube **188** which is used to measure air velocity; a GPS receiver and magnetometer **190** which provide three-dimensional positioning and heading information; an inertial measuring unit which can be used to augment GPS or when GPS is not available, to control the glider; flight controller CPU, status LED light **192**, and an interface plug **193** which allows programming the CPU to control the flight path of the glider from launch to the logistics delivery point and provides for uploading the drop position and en route way points. Power is provided by a battery and solid-state power converter **194** which can provide approximately 15 watt-hours and the voltage necessary to drive the servos and to power the other electronics. The battery has an on-off switch which is switched on shortly before the glider is deployed on a cargo delivery mission.

**[0034]** The center of gravity (CG) of the glider **20** i.e., the point around which the resultant torque due to gravity forces vanishes, is located along the load strap **54** halfway between the wing struts attachment bolts **57**. In order to maintain glider stability and maximize glider range the payload must be arranged in the payload bay so the CG location remains remain unchanged. This may be accomplished by

placing a wheel on either side of the skid board **26** so that the glider is balanced with the axis of rotation of the wheels passing through the CG and underlying the load strap **54**. The payload is then positioned within the payload bay such that the glider containing the payload remains balanced about the axis of rotation of the wheels and thus the center of gravity of the glider. Two wheels on a single axis, or a pair of helicopter wheels, which have one or two clamps such as screw clamps or over center clamps like a vise-grip can be used. The wheels, like helicopter wheels, which incorporate an over center mechanism to lift the glider and place the wheel axis under the CG for towing from the payload loading site to the launch aircraft may also be used. Because the glider is expendable the payload can be restrained in the payload bay by adding attach points by drilling holes in the sides **24** or the floor panel **48** or by attaching screw hooks or eyes in the sides or floor panel for the attachment of rigging lines.



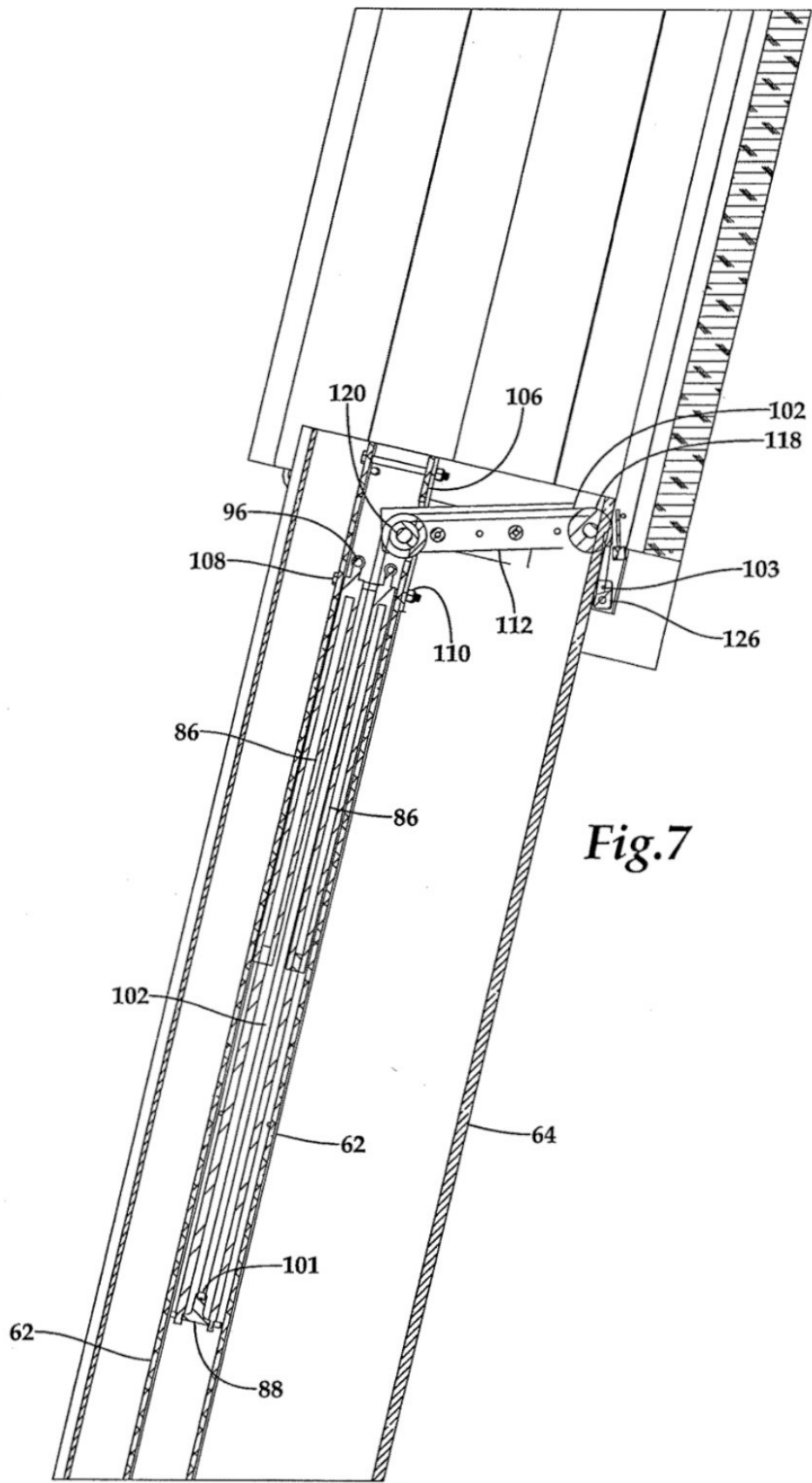

*Fig. 7*

[0035] It should be understood that the plywood panels and frames making up the glider fuselage could be joined by piano hinges for rapid assembly by military personal. One side of the piano hinge is

pre-screwed to each side of each joint to be formed so that the joint can be completed by simply inserting a hinge pin.

**[0036]** It should be understood that the logistic glider **20** is relatively scalable within limits, for example, 250–5000 lbs. with a preferred payload between 500 and 2000 lbs. It is further understood that the payload can be increased by increasing wing span and/or wing attack angle, or the flight velocity.

**[0037]** It should be understood that the glider **20** may have more than one rudder and one or more vertical or horizontal stabilizers.

**[0038]** It is understood that the invention is not limited to the particular construction and arrangement of parts herein illustrated and described, but embraces all such modified forms thereof as come within the scope of the following claims.

We claim:

1. An expendable logistic glider comprising:

a fuselage having a nose and a tail, and a longitudinal axis extending therebetween, portions of the fuselage between the nose and the tail defining a cargo bay;

a fuselage bridging spar which is fixedly mounted to the fuselage;

a port wing spar pivotally mounted to the fuselage bridging spar, and a starboard wing spar pivotally mounted to the fuselage bridging spar, opposite the port wing spar;

wherein the port wing spar extending at least partly through a rigid airfoil to form a port wing;

wherein the starboard wing spar extending at least partly through a rigid airfoil to form a starboard wing;

a first source of stored energy mounted within the port wing to act on a first anchor attached to the fuselage to rotate the port wing from a

first position at least partially over the fuselage to a second position perpendicular to the longitudinal axis of the fuselage;

a second source of stored energy mounted within the starboard wing to act on a second anchor attached to the fuselage to rotate the starboard wing from a first position at least partially over the fuselage to a second position perpendicular to the longitudinal axis of the fuselage.

**2.** The logistic glider of claim 1 wherein the first source of stored energy is a gas spring mounted within the port wing spar, the gas spring attached to a flexible member which is attached to the first anchor such that the gas spring is acted on by the flexible member to compress the gas spring when the port wing is in the first position at least partially over the fuselage, and the gas spring acts on the flexible member to pivot the port wing to the second position perpendicular to the longitudinal axis of the fuselage;

and wherein the second source of stored energy is a gas spring mounted within the starboard wing spar, the gas spring attached to a flexible member which is attached to the second anchor such that the gas spring is acted on by the flexible member to compress the gas spring when the starboard wing is in the first position at least partially over the fuselage, and the gas spring acts on the flexible member to pivot the starboard wing to the second position perpendicular to the longitudinal axis of the fuselage.

**3.** The logistic glider of claim 2 wherein the gas spring within the port wing spar is formed by two gas spring pistons having first ends connected to a bracket, wherein the flexible member is also connected to the bracket;

wherein two gas spring pistons having second ends connected to the port wing spar adjacent to portions of the port wing spar which forms an opening through the port wing spar;

a pivot bracket fixedly mounted to an exterior portion of the port wing spar adjacent to the opening through the port wing spar, the pivot bracket mounted to a pivot shaft which is mounted to the fuselage bridging spar to pivotally mount the port wing spar;

a flexible member guide mounted to the pivot bracket and extending away from the port wing spar;

wherein the flexible member extends through the opening through the port wing spar and outwardly from the port wing spar along the guide to the anchor, and

wherein the flexible member guide and the pivot bracket form an arm which applies tension to the flexible member when the port wing is moved from the second position perpendicular to the longitudinal axis of the fuselage, to the first position at least partially over the fuselage so as to compress the two gas spring pistons.

4. The logistic glider of claim 2 wherein the rigid airfoils which form the port and starboard wings have a plastic extrusion having a plurality of jury spars connecting an upper and a lower surface which form the air foil.

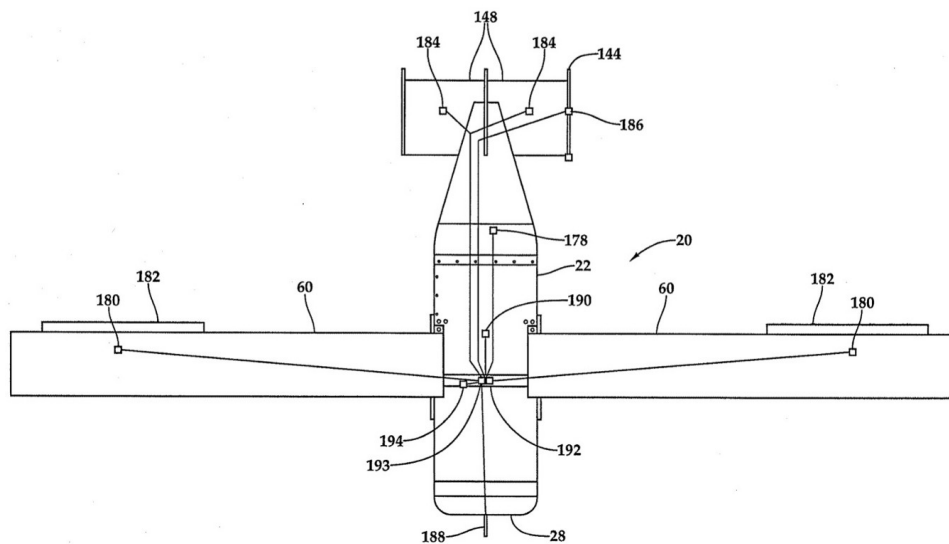

*Fig.8*

5. An expendable logistic glider comprising:



a fuselage having a nose and a tail, and a longitudinal axis extending therebetween, portions of the fuselage between the nose and the tail defining a cargo bay;

two wing spars pivotally mounted to the fuselage on opposite sides of the fuselage;

wherein each wing spar extends through a rigid plastic extrusion having a plurality of jury spars connecting an upper and a lower surface which form a wing;

wherein each wing has a wing strut pivotally connected to the corresponding one of the wing spars, the wing strut pivotally connected to the fuselage spaced vertically from where the wing spar is mounted to the fuselage such that the wing strut pivots with the wing.

**6.** The logistic glider of claim **5** further comprising;

a spring mounted within each wing to act on an anchor attached to the fuselage to rotate the wing from a first position at least partially over the fuselage to a second position perpendicular to the longitudinal axis of the fuselage.

**7.** The logistic glider of claim **6** wherein the spring is a gas spring mounted within each wing spar, and the gas spring is attached to a flexible member which is attached to an anchor, such that the gas spring is acted on by the flexible member to compress the gas spring when the wing is in the first position at least partially over the fuselage, and the gas spring retracts the flexible member into the wing to pivot the wing to the second position perpendicular to the longitudinal axis of the fuselage.

**8.** The logistic glider of claim **7** wherein the gas spring within each wing spar is formed by two gas spring pistons having first ends connected to a bracket, wherein the flexible member is also connected to the bracket;

wherein two gas spring pistons having second ends connected to the wing spar adjacent to a portion of the port wing spar which forms an opening through the wing spar;

each wing spar having a pivot bracket fixedly mounted to an exterior portion of the wing spar adjacent to the opening through the wing spar, the pivot bracket mounted to a pivot which is mounted to the fuselage;

a flexible member guide mounted to the pivot bracket and extending away from the wing spar;

wherein the flexible member extends through the opening through the wing spar and outwardly from the wing spar along the guide to the anchor, and

wherein the flexible member guide and the pivot bracket form an arm which applies tension to the flexible member when the wing is moved from the second position perpendicular to the longitudinal axis of the fuselage, to the first position at least partially over the fuselage so as to compress the two gas spring pistons.

**9. An expendable logistic glider comprising:**

a fuselage having a nose, a tail, a lower belly surface and a longitudinal axis extending therebetween; the nose, the tail, and portions of the fuselage between the nose and the tail defining a cargo bay overlying the lower belly surface;

two wing spars pivotally mounted to the fuselage on opposite sides of the fuselage;

wherein each wing spar extends through a rigid plastic extrusion to form a wing; a skid board fixedly mounted to the lower belly surface of the fuselage and extending beyond the fuselage in a direction perpendicular to the longitudinal axis;

wherein the skid board is arranged to form a launch surface and a landing surface by which the logistic glider is launched from a cargo plane and lands on a surface at a target drop zone; wherein the tail has a lower surface portion having a forward edge and an aft edge spaced apart along the longitudinal axis, the lower surface portion forms at least part of a container integral with the lower surface portion, the container extending into the tail;

a parachute positioned in the container for deployment;

wherein the lower surface portion aft edge is pivotally mounted to a portion of the tail which underlies the aft edge;

an actuator which is mounted to the fuselage and connected so as to hold the forward edge of the lower surface portion to the fuselage;

a static line connected between the fuselage and a pack containing the parachute so as to release the parachute from the pack, and a plurality of riser lines connecting the parachute to the tail of the fuselage so that the logistic glider will be supported by the tail upon deployment;

wherein the container integral with the lower surface portion is connected to the parachute so as to form a drogue for extraction of the parachute from the logistic glider when the actuator releases the forward edge of the container allowing it to rotate into a slipstream under the lower belly surface.

**10.** The logistic glider of claim 9 wherein the nose of the fuselage is in a frame of concrete which is filled with a layer of paperboard honeycomb panel, and is attached to a forward frame of the fuselage, wherein the cargo bay adjacent the forward frame is filled with 3–9 inches of paperboard honeycomb panel.

**11.** The logistic glider of claim 9 wherein each wing has a wing strut pivotally connected to the corresponding one of the wing spars, the wing strut pivotally connected to the fuselage spaced vertically from

where the wing spars are mounted to the fuselage such that the wing strut pivots with the wings.

**12.** The logistic glider of claim 9 further comprising;

a spring mounted within each wing to act on an anchor attached to the fuselage to rotate the wing from a first position at least partially over the fuselage to a second position perpendicular to the longitudinal axis of the fuselage.

**13.** The logistic glider of claim 12 wherein the spring is a gas spring mounted within each wing spar, and the gas spring is attached to a flexible member which is attached to an anchor, such that the gas spring is acted on by the flexible member to compress the gas spring when the wing is in the first position at least partially over the fuselage, and the gas spring retracts the flexible member into the wing to pivot the wing to the second position perpendicular to the longitudinal axis of the fuselage.

**14.** The logistic glider of claim 13 wherein the gas spring within each wing spar is formed by two gas spring pistons having first ends connected to a bracket, wherein the flexible member is also connected to the bracket;

wherein two gas spring pistons having second ends connected to the wing spar adjacent to a portion of the port wing spar which forms an opening through the wing spar;

each wing spar having a pivot bracket fixedly mounted to an exterior portion of the wing spar adjacent to the opening through the wing spar, the pivot bracket mounted to a pivot which is mounted to the fuselage;

a flexible member guide mounted to the pivot bracket and extending away from the wing spar;

wherein the flexible member extends through the opening through the wing spar and outwardly from the wing spar along the guide to the



anchor; and

wherein the flexible member guide and the pivot bracket form an arm which applies tension to the flexible member when the wing is moved from the second position perpendicular to the longitudinal axis of the fuselage, to the first position at least partially over the fuselage so as to compress the two gas spring pistons.

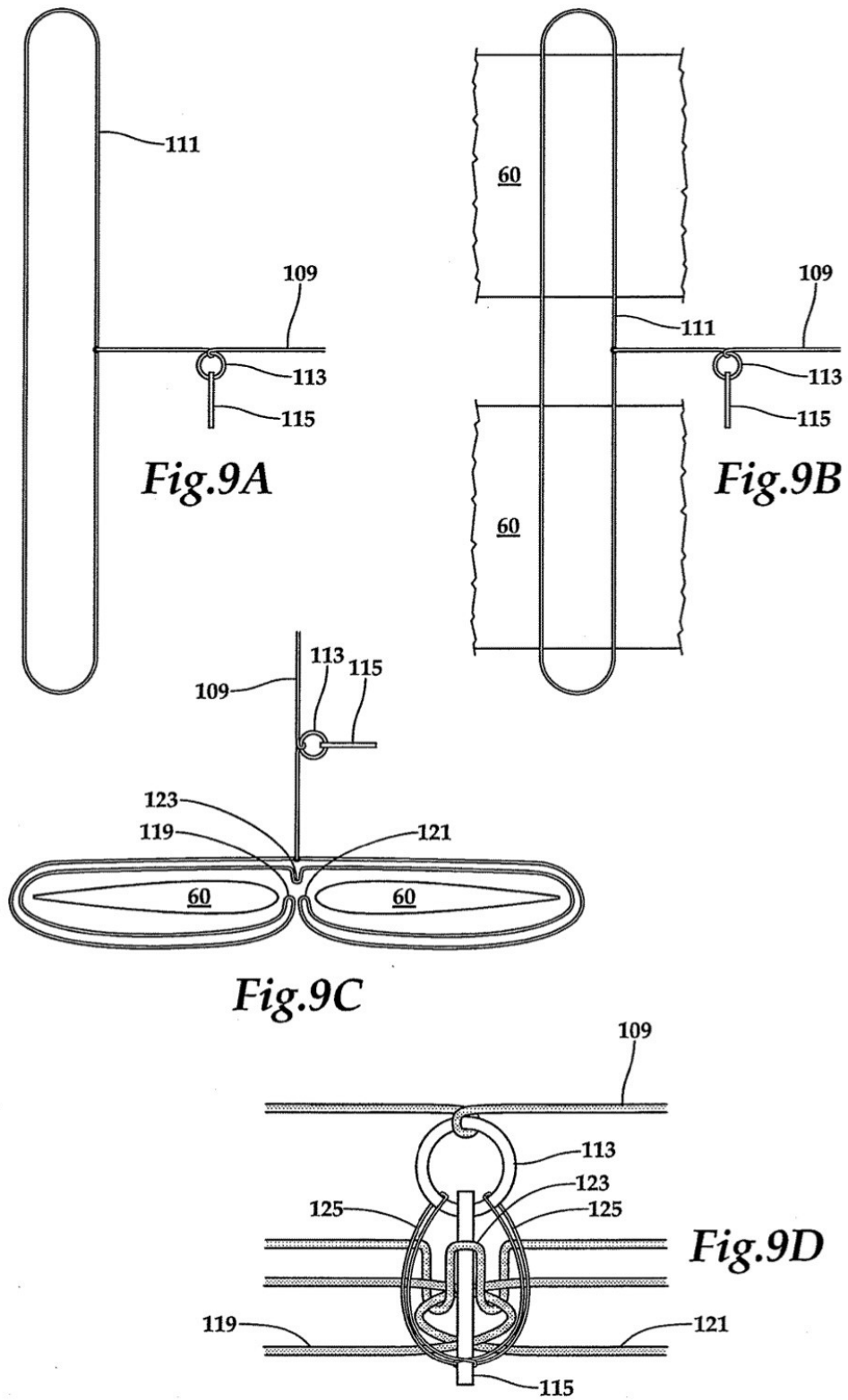

15. An expendable logistic glider comprising:

a fuselage constructed from a plurality of precut panels cut from at least one of medium density overlay (MDO) and high density overlay (HDO) plywood having a flat nose and a triple-tail having three vertical stabilizers, the fuselage defining a longitudinal axis extending

between the nose and the tail, portions of the fuselage between the nose and the tail defining a cargo bay;

wherein the plurality of precut panels are joined by at least one of pocket-screw joinery and piano hinges, where one side of the piano hinge is screwed to each side of each of a plurality of joints joined by an inserted hinge pin;

two wing spars pivotally mounted to the fuselage on opposite sides of the fuselage;

wherein each wing has a wing strut pivotally connected to the corresponding one of the wing spars, the wing strut pivotally connected to the fuselage spaced vertically from where the wing spars are mounted to the fuselage such that the wing strut pivots with the wings;

a rigid airfoil which is fitted over each wing spar;

a skid board fixedly mounted to the lower belly surface of the fuselage and extending beyond the fuselage in a direction perpendicular to the longitudinal axis;

wherein the skid board is arranged to form a launch surface and a landing surface by which the logistic glider is launched from a cargo plane and lands on a surface at a target drop zone;

a parachute positioned in the tail for deployment;

an actuator which is mounted to the fuselage and connected so as to deploy the parachute;

a static line connected between the fuselage and a pack containing the parachute so as to release the parachute, and a plurality of riser lines connecting the parachute to the tail of the fuselage so that the logistic glider will be supported by the tail upon deployment.

**16.** The logistic glider of claim **15** wherein the plurality of precut panels are joined by pocket-screw joinery.

**17.** The logistic glider of claim **15** wherein the plurality of precut panels are joined by piano hinges joined by an inserted hinge pin.

**18.** The logistic glider of claim **15** further comprising; a spring mounted within each wing to act on an anchor attached to the fuselage to rotate the wing from a first position at least partially over the fuselage to a second position perpendicular to the longitudinal axis of the fuselage.

**19.** The logistic glider of claim **18** wherein the spring is a gas spring mounted within each wing spar, and the gas spring is attached to a flexible member which is attached to an anchor, such that the gas spring is acted on by the flexible member to compress the gas spring when the wing is in the first position at least partially over the fuselage, and the gas spring retracts the flexible member into the wing to pivot the wing to the second position perpendicular to the longitudinal axis of the fuselage.

**20.** The logistic glider of claim **19** wherein the gas spring within each wing spar is formed by two gas spring pistons having first ends connected to a bracket, wherein the flexible member is also connected to the bracket;

wherein two gas spring pistons having second ends connected to the wing spar adjacent to portions of the port wing spar which forms an opening through the wing spar;

each wing spar having a pivot bracket fixedly mounted to an exterior portion of the wing spar adjacent to the opening through the wing spar, the pivot bracket mounted to a pivot which is mounted to the fuselage;

a flexible member guide mounted to the pivot bracket and extending away from the wing spar;

wherein the flexible member extends through the opening through the wing spar and outwardly from the wing spar along the guide to the anchor, and

wherein the flexible member guide and the pivot bracket form an arm which applies tension to the flexible member when the wing is moved from the second position perpendicular to the longitudinal axis of the fuselage, to the first position at least partially over the fuselage so as to compress the two gas spring pistons.

## Resources

- [US Patent and Trademark Office](#) (USPTO) – The USPTO provides an outstanding search engine which enables digging through (seemingly) every patent in their office.
- [US Patent 2018/0086449 A1](#) – A PDF of the original patent as downloaded from the USPTO website, on which this article is based.

*Read the [next article](#) in this issue, return to the [previous article](#) in this issue or go to the [table of contents](#). A PDF version of this article, or the entire issue, is available [upon request](#).*

Unlisted



## The Trailing Edge



There's a Brasil-based Instagram account we follow, 'TreknFly', and here's just one of the many reasons why: photographer Rodrigo Lessaf captured pilot Léo Horta's 'Samurai' on a late sunset flight at Serra da Calçada, Minas Gerais, Brasil on July 22nd, 2022. We predict Brasil being added to many, 'must soar someday' bucket lists. See Resources for relevant links.

## Wasps.

"They're back", lamented our fearless Managing Editor. Without looking up from the still-not-quite-in-the-can August issue we knew exactly what he meant. The crack between some pavers just outside the home office of the New RCSD was once again the unwelcome home to an extended family – likely many extended families – of wasps. Or more accurately, yellowjackets. These are the tinier, nastier, gangster cousin of the more upstanding honey bee or bumble bee.

"Lots of them?" we asked as we began to spin the Rolodex looking for *The Orkin Man*, as we assumed that's the next call we'd be making.

"No, just one or two, but you know what that means, right? Once or two now, one or two *hundred* a few days from now" he said. But this was the middle of a blisteringly hot long weekend here in Canada so

the chances of tracking down the contract killers of insects was essentially zero. Some time on the phone confirmed we were on our own until at least Tuesday. With that frightening information in hand, he came up with an 'brilliant' alternative plan: "I think I'll just put a couple of scoops of dirt over the one entrance and be done with it." His voice trailed off as he went outside and prepared to do battle.

We had a bird's eye view from inside and could see the surprise attack, the Ed running for his life, and then provide intel for a pretty decent after-action report. Put in purely entomological terms, the yellowjackets were *pissed*. Some after the fact googling revealed that not only would all the members of the hive be alerted to the threat, but that they were capable of emitting some sort of signal that would attract allied troops from other nests in the area. A day late and dollar short, we immediately visualised a 'beard of bees' carpet on the new dirt pile. Yes, grown adults looking through a pane of a glass, quaking in fear of tiny insects.

Instantly there were 20 or 30 buzzing around the now seemingly entombed and doomed nest. We simply assumed that as soon as their energy, food and water ran out they would be off and that would be that. We closed the blinds and thought of more pleasant things.

You can therefore imagine our utter shock when, a couple of hours later, we took a look outside and found this:



The legions of wasps which had been summoned in response to the Ed's pathetic, ill-informed attempts at pest control were not there to attack the attacker – although they might have, if given the opportunity – but rather to set about simply dealing with the problem that was immediately in front of them. They **dug out the entrance to their nest** and were simply now going on about their business again. The squadrons had dispersed, returned to home base and the colony was once again calm.

Which got us thinking: if the ad hoc collection of grain-of-sand-sized, million-year-old brains of these six-legged geniuses had managed this unbelievable feat of engineering, in record time, all without any sort of command and control then, frankly, it's easy to believe that **all things are possible**.

Taking our lead from from the now little-less-lowly yellowjacket, we simply have to focus on the problem which is immediately in front of us, stop bitching and complaining and **get on with it**.

What's more the wasps – which are, after all, a part of our little garden ecosystem – have earned the right to stay.

## What's New in The RCSD Shop



Introducing the RCSD Retro Logo Polo Shirt.

Combine style and class with our brand new [RCSD Retro Logo Polo Shirt](#). It features the beautifully embroidered logo reminiscent of the early RCSD logo created by the late Robert 'Bob' Rondeau. Bob was the Graphics and Art Director for RCSD when the logo first appeared on the cover of the January, 1985 issue. It's available in five great colours.

This product is made especially for you as soon as you place an order, which is why it takes us a bit longer to deliver it to you. Making products on demand instead of in bulk helps reduce overproduction, so thank you for making thoughtful purchasing decisions and helping to support the New RCSD!

## **Make Sure You Don't Miss the New Issue**

You really don't want to miss the September issue of RCSD when it's out – we always have some exciting things in the works. Make sure you connect with us on [Facebook](#), [Instagram](#), [Twitter](#) or [LinkedIn](#) or subscribe to our [Groups.io mailing list](#). Please share RCSD with your friends – we would love to have them as readers, too.

That's it for this month...now get out there and fly!

©2022